

eclipse SMX24 Installation Manual

60-0531 - SMX24 Blue - Single Light - Surface Mount

60-0532 - SMX24 White - Single Light - Surface Mount

60-0533 - SMX24 Blue and White - Single Light - Surface Mount



Please read the following pages before attempting installation to ensure complete understanding of Lumishore ECLIPSE SMX24. This product should only be installed, inspected, and maintained by a qualified electrician only, in accordance with all applicable electrical codes. Be certain electrical power is OFF before and during installation and maintenance.

Color Output
Single and dual color

Voltage
12-24V DC
(10.5 - 31V DC)



Before you start:

- Always ensure that the vessel's power source and battery are disconnected or isolated prior to installation.
- A qualified professional should carry out both the electrical and mechanical installation.
- For best underwater illumination, LUMISHORE recommends installation 4" to 12" (100-300mm) below the minimum load water line.
- Choose a location - The light must be mounted on a flat (not curved) surface. For underwater installs mount on transom or side hull only.
- A hole will be drilled to allow the cable to be inserted; care must be taken to ensure there is unrestricted access inside the hull.
- When installing three or more lights, equal spacing 2.5'- 3' is recommended to give a consistent light pool.
- The light is temperature sensitive and must not be located close to the exhaust outlet or other heat source.
- SMX24 Lights operate on 12V or 24V DC (10.5-31V DC). Never connect a light directly to the mains AC voltage, or DC voltage other than that specified.
- Each light should be individually fused with the correctly rated fuse. 4A for 12V and 2A for 24V.
- For Installation on boats up to 7.5m (25 ft). Isolation kit (39-0203) MUST be used on boats with conductive hulls.

Basic Dimensions

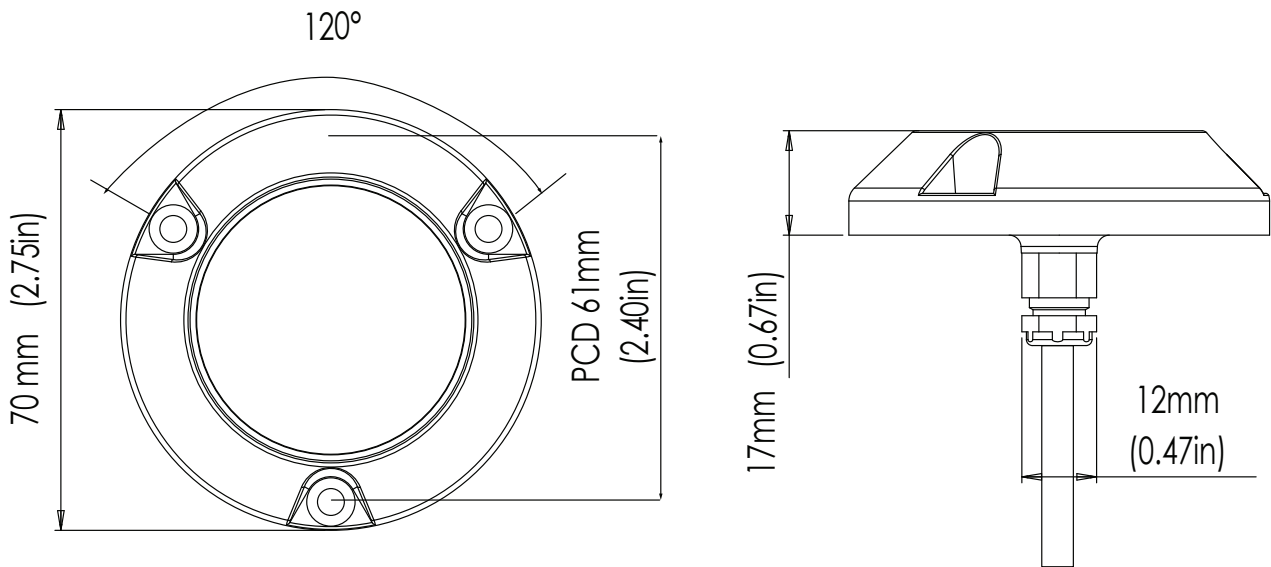

Mechanical installation

Tools: Drill, drill bits, marine sealant (3M 4200, or equivalent), F2 Frearson type screwdriver, Flat head screw driver, cloth for clean-up:

Pilot Hole for Screws - 9/64" / 3.5mm

Hole for Cable - 9/32" / 7mm

Recess for Gland - 17/32" / 13.5mm hole to a depth of 5/8" / 15mm

1. Select a suitable flat surface that is accessible from behind and ensure the cable can be run without a problem.
2. With one hole at the bottom center, mark and drill the pilot holes for the screws & drill a $\varnothing 4$ mm counter bore to a depth of 5mm in each location. Drill the power cable hole. The cable hole must be recessed on the outside of the hull to accept the cable gland on the back of the light, so that the lights sits flush.

Note: Cored hulls must be sealed prior to fitting the lights - refer to the manufacturers instructions.

3. Clean and prepare the hull ready for the sealant.

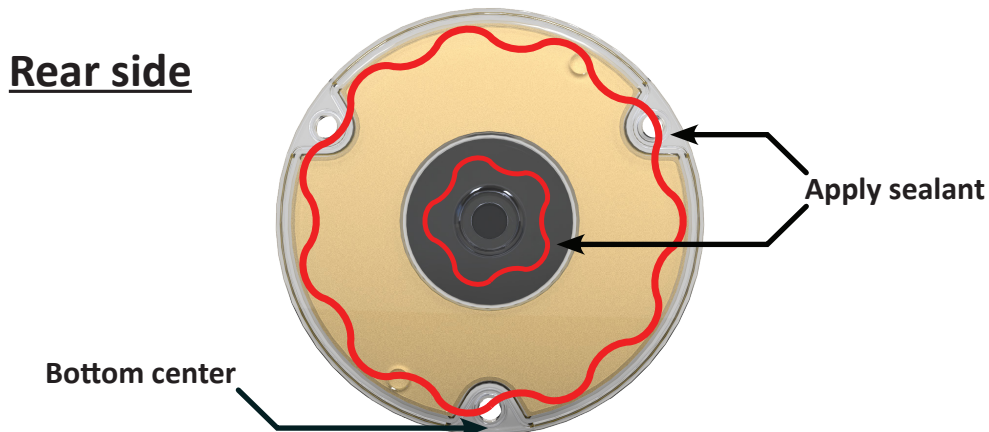

4. Apply a continuous thick bead of sealant to the back of the light, making sure the recess on the outer edge is slightly overfilled. Also apply a bead of sealant around the cable gland. Refer to image above.
5. Push the power cable through the hole and align the light with the pilot hole screws.
6. Attach the light using the 3 supplied screws by hand tightening with a screwdriver.

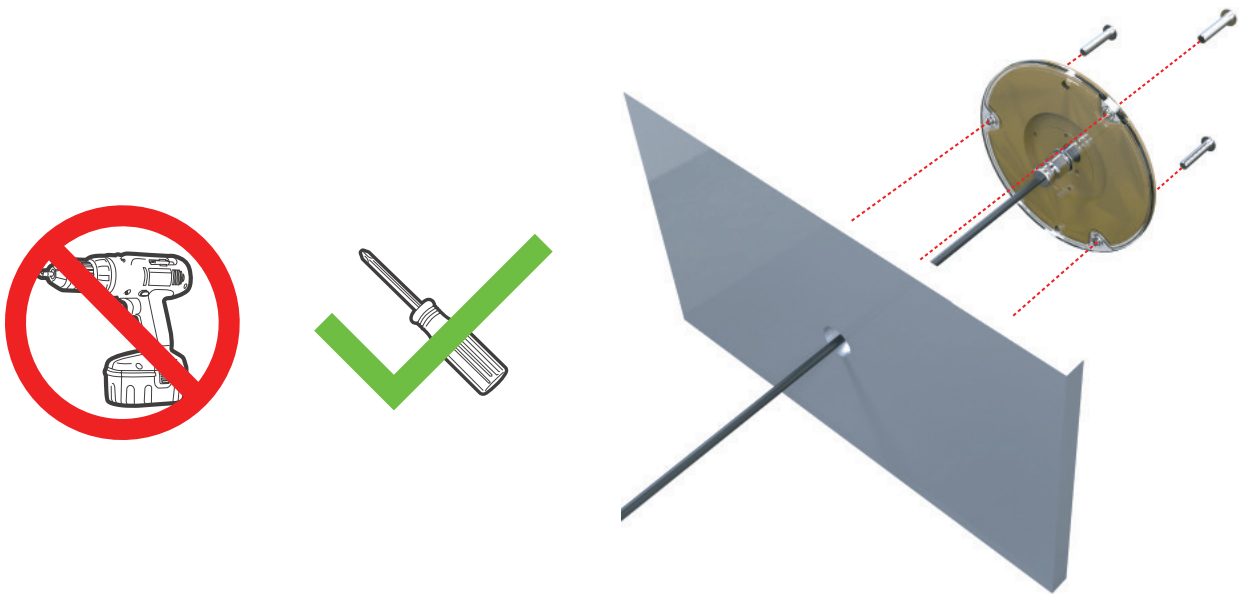

IMPORTANT: Do not over tighten. Do not use power tools to tighten screws.

7. Use a damp cloth to wipe off excess sealant that has squeezed out around the light. DO NOT use chemical cleaners or solvents.

IMPORTANT: Refer to the directions on the sealant to make sure it has fully cured before launching the boat into the water.

Electrical installation

Plan the cable route prior to installation. Ensure all cables are suitable for marine applications, and correctly rated for the required voltage and current. Each light must be individually fused. The cable connections are:

Red	12V or 24V DC (10.5 - 31V DC)
Black	Ground

Fuse ratings:	12V DC	4A
	24V DC	2A

An ON / OFF switch should be installed to select the modes of operation. All connections must be made waterproof.

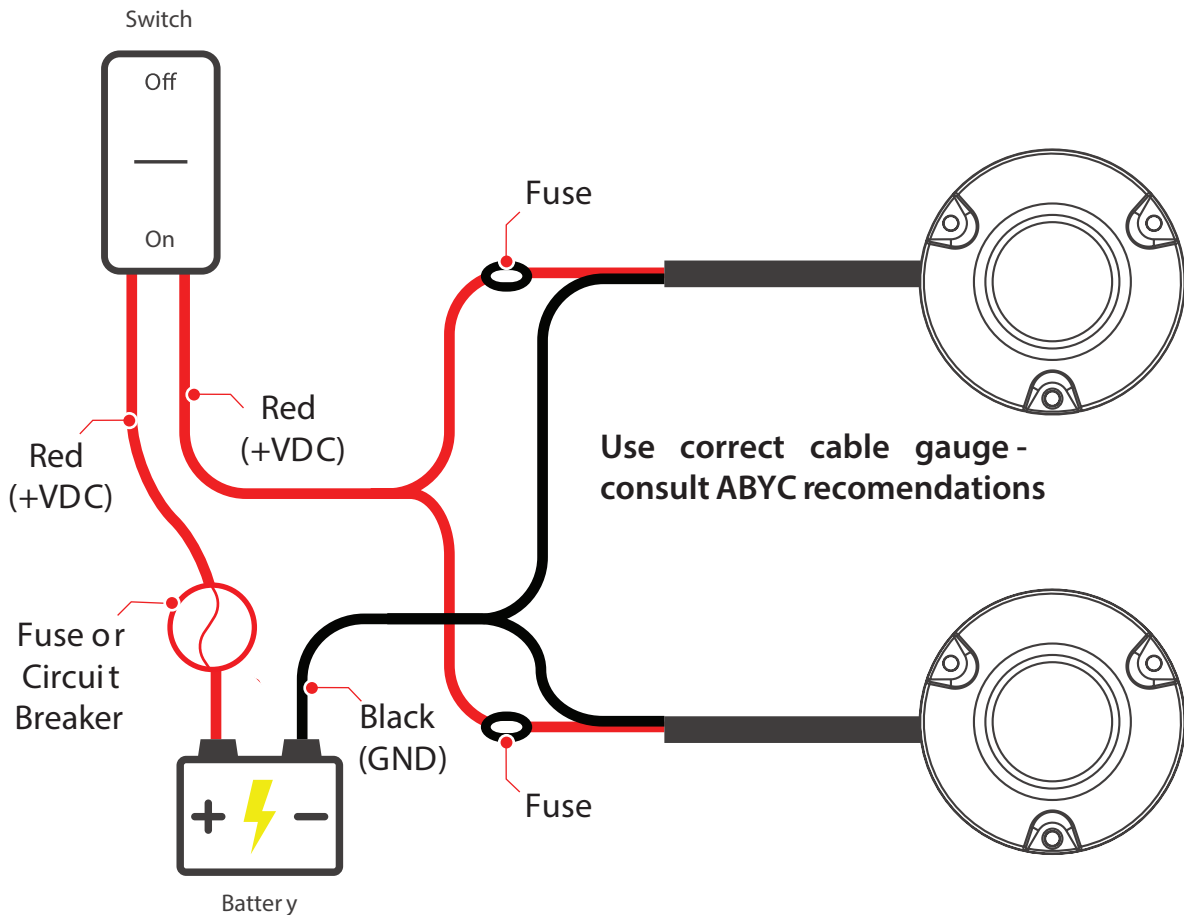

The light cables can be extended. Ensure the correct cable gauge is used to avoid issues with voltage drop. Follow ABYC recommendations for no more than 3% voltage drop at 12V, and 10% at 24V. Consult a qualified electrical installer, or contact Lumishore for further information.

Make sure the lights are tested, and working as expected before the boat goes back in the water.

Switch operation - Dual color lights

The lights operate in White, Blue, Random Strobe, and Color Fade modes. To change the mode turn the switch OFF / ON (within 2 seconds). To reset to White mode, switch the lights off for 5 seconds. The lights will always come on in White mode when first switched on.

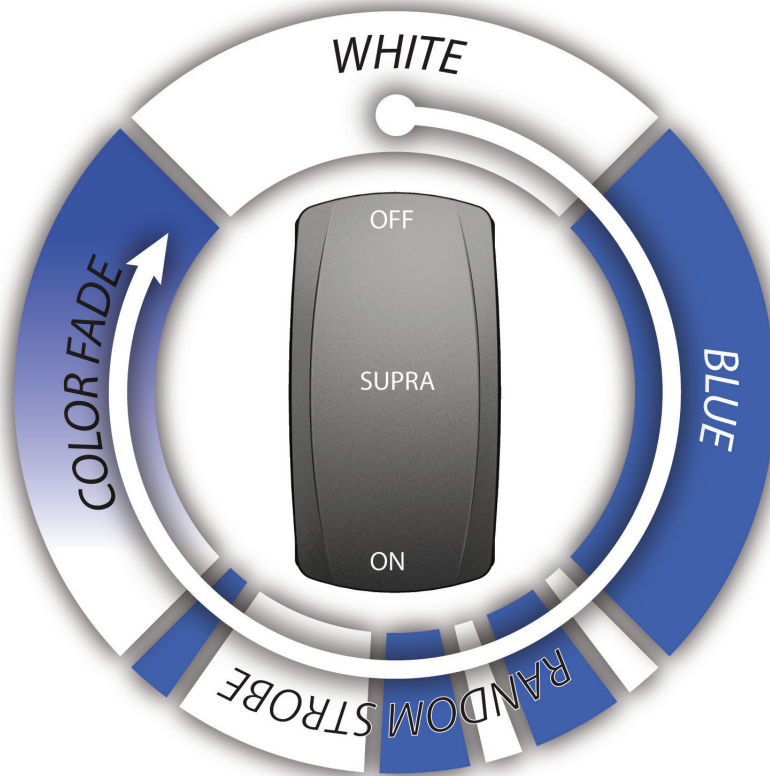

Installation Diagram - Eclipse Command Center

Note: For full ECLIPSE Command Center control consult ECLIPSE Command Center installation manual

Before continuing ensure the Yellow wire from the light has been exposed (see below)

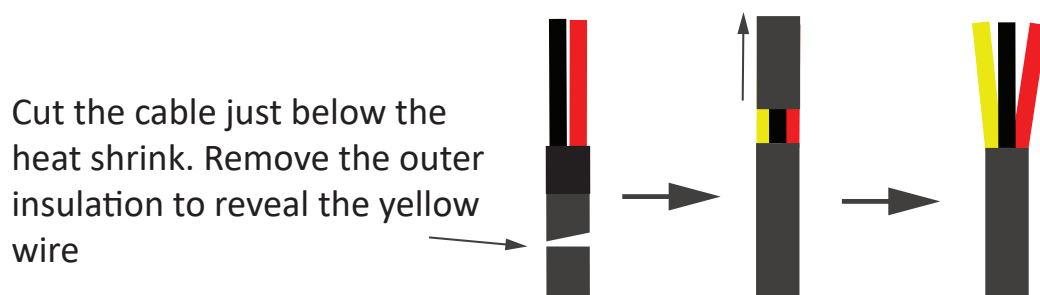

Up to 4 lights per Command Center



Important! The ECLIPSE Command Center installation is suitable for 12V boats ONLY.

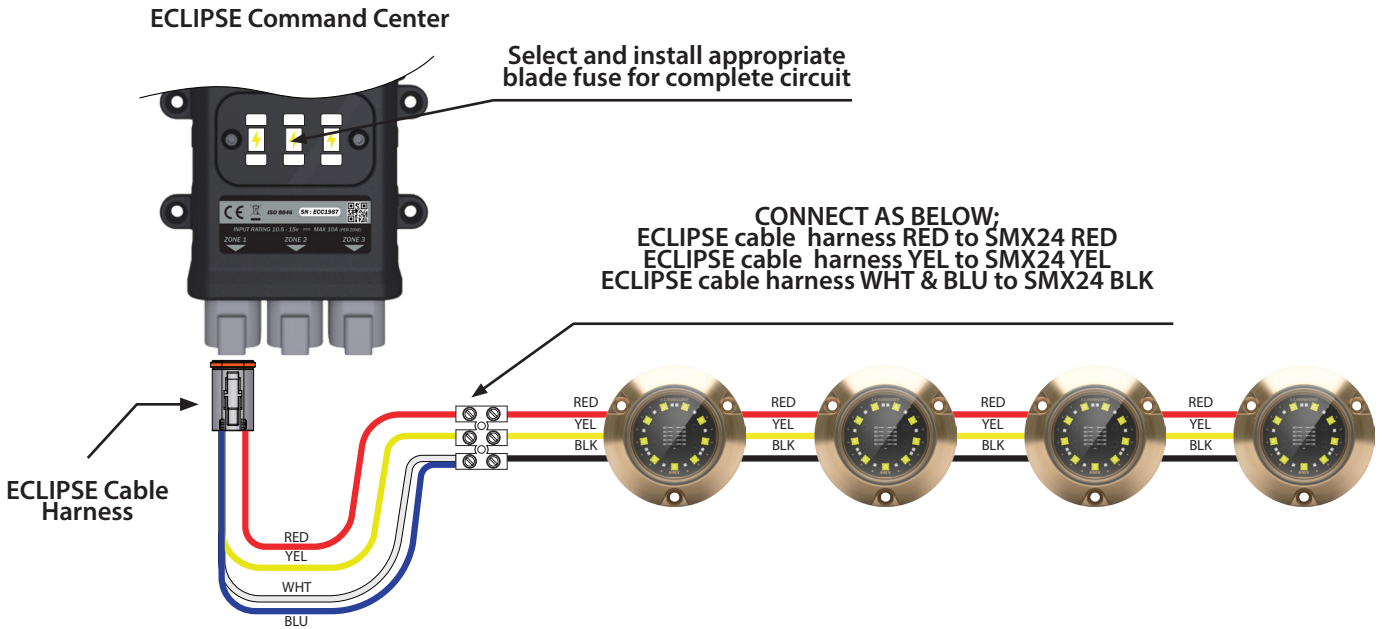

More than 4 lights per Command Center

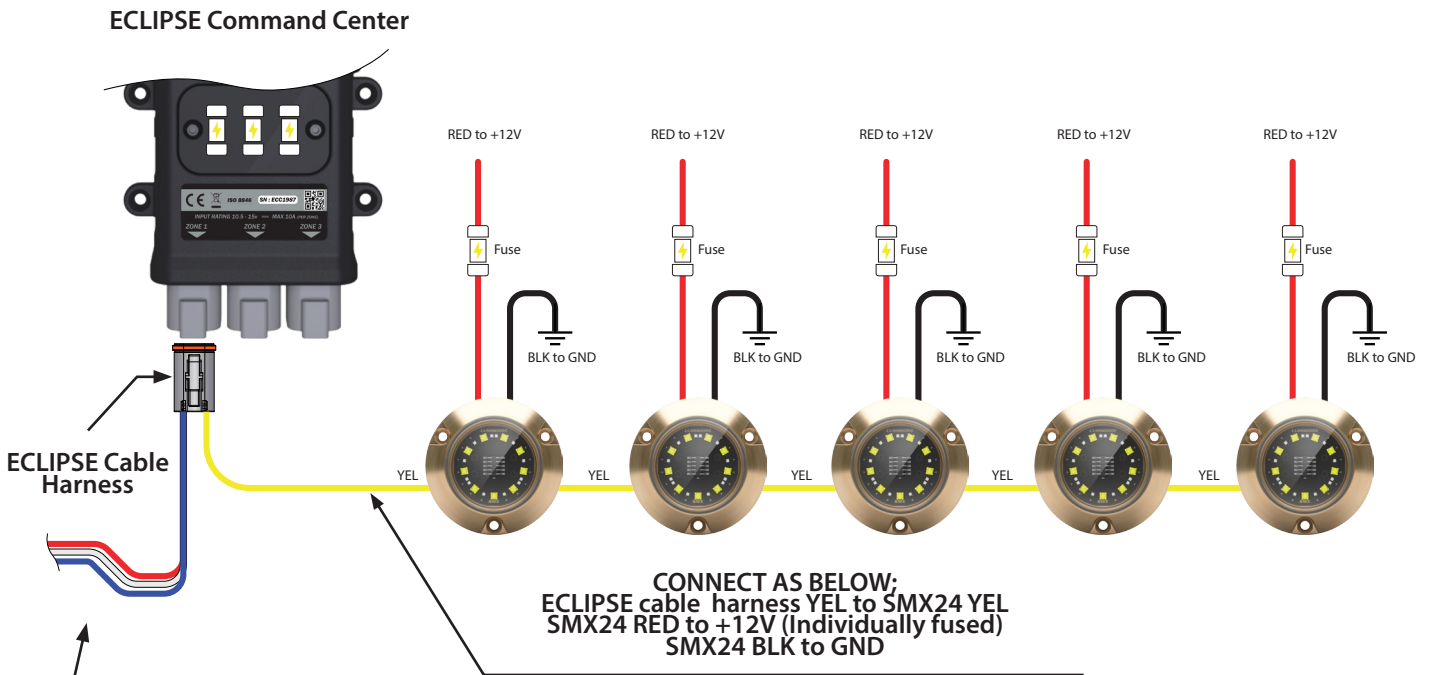

RED, WHT and BLUE - No connect.
Ensure any unused wires are isolated.

Note : Single color and dual color lights should not be added to the same zone output. Use a separate zone output for each type.

Cleaning and maintenance

LUMISHORE lights require simple cleaning. Lights should be checked often to ensure the light body and lens area are free from sea growth. In the event that your light requires cleaning, we recommend the use of a soft cloth or soft bristled brush.

- DO NOT use any abrasive cleaning materials as these may damage the body of the light.
- DO NOT use any cleaning fluids that contain solvents, acids or alkali's.
- DO NOT clean using pressure washing or sandblasting equipment.

Slight discoloration of body may occur over life. This does not affect performance, and is not subject to warranty.

Due to nature and high build quality it may on rare occasions be possible to see small levels of condensation, this is normal for high power LEDs and will disappear after cooling and does not harm operation in any way.

If the lens of the light is covered for any reason, e.g. maintenance, or painting DO NOT switch the lights on until the covers are removed.

Warranty

LUMISHORE Ltd warrants its lighting systems and associated lights and accessories to be free from defects in workmanship for a period of three years, starting from the date of original purchase. Should your lighting system have a problem during this period, please contact your dealer, boat manufacturer or broker as soon as you become aware of the defect.

Misuse, abuse, improper installation, neglect, improper shipping, damage caused by disasters (e.g. fire, flood, storm and lightning), installation by unqualified personnel, unauthorized repair or modification or non-approved installations will void this warranty. For the avoidance of confusion and doubt, non compliance with all installation guidelines, maintenance and operating instructions in this document constitute non conformance with warranty terms.

Full warranty details including exclusions are available at -

www.lumishore.com

