

GARMIN®

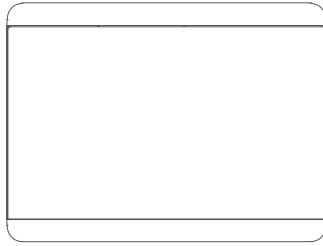

GHC™ 50

INSTALLATION INSTRUCTIONS

Important Safety Information

⚠ WARNING

Failure to follow these warnings, cautions, and notices could result in personal injury, damage to the vessel or device, or poor product performance.

See the *Important Safety and Product Information* guide in the product box for product warnings and other important information.

⚠ CAUTION

To avoid possible personal injury, always wear safety goggles, ear protection, and a dust mask when drilling, cutting, or sanding.

To avoid possible personal injury or damage to the device and vessel, disconnect the vessel's power supply before beginning to install the device.

To avoid possible personal injury or damage to the device or vessel, before applying power to the device, make sure that it has been properly grounded, following the instructions in the guide.

NOTICE

For the best possible performance, the device must be installed according to these instructions.

When drilling or cutting, always check what is on the opposite side of the surface to avoid damaging the vessel.

Tools Needed

- Drill and drill bits
 - Preparing the surface for cutting:
 - 9 mm ($\frac{3}{8}$ in.) bit
 - Installs using wood screws:
 - 2.5 mm ($\frac{3}{32}$ in.) bit
 - Installs using the nut plate:
 - 3.5 mm ($\frac{9}{64}$ in.) bit
 - 4 mm ($\frac{5}{32}$ in.) bit
- #2 Phillips screwdriver
- Jigsaw or rotary tool
- File and sandpaper
- Marine sealant (recommended)

Mounting Considerations

NOTICE

This device should be mounted in a location that is not exposed to extreme temperatures or conditions. The temperature range for this device is listed in the product specifications. Extended exposure to temperatures exceeding the specified temperature range, in storage or operating conditions, may cause device failure. Extreme-temperature-induced damage and related consequences are not covered by the warranty.

The mounting surface must be flat to avoid damaging the device when it is mounted.

When selecting a mounting location, observe these considerations.

- The mounting location should be at or below eye level to provide optimal viewing as you operate your vessel.
- The mounting surface must be strong enough to support the weight of the device and protect it from excessive vibration or shock.
- To avoid interference with a magnetic compass, the device should not be installed closer to a compass than the compass-safe distance value listed in the product specifications.
- The area behind the mounting surface must allow room for the routing and connection of the cables.

The included template and hardware can be used to flush mount the device in your dashboard. There are two options for hardware based on the mounting surface material.

- You can drill pilot holes and use the included wood screws.
- You can drill holes and use the included nut plates and machine screws. The nut plates can add stability to a thinner surface.

Mounting the Device

NOTICE

Be careful when cutting the hole to flush mount the device. There is only a small amount of clearance between the case and the mounting holes, and cutting the hole too large could compromise the stability of the device after it is mounted.

To avoid potential damage to the device, use only the included screws to mount it. Using screws other than the ones included will void your warranty.

The included template and hardware can be used to flush mount the device in your dashboard. There are two options for hardware based on the mounting surface material.

- You can drill pilot holes and use the included wood screws.
- You can drill holes and use the included nut plates and machine screws. The nut plates can add stability to a thinner surface.

- 1 Trim the template and make sure it fits in the location where you want to mount the device.
- 2 Secure the template to the selected location.
- 3 Using a 9 mm ($\frac{3}{8}$ in.) drill bit, drill one or more of the holes inside the corners of the solid line on the template to prepare the mounting surface for cutting.
- 4 Using a jigsaw or rotary tool, cut the mounting surface along the **inside** of the solid line indicated on the template.
- 5 Place the device in the cutout to test the fit.
- 6 If necessary, use a file and sandpaper to refine the size of the cutout.
- 7 After the device fits correctly in the cutout, ensure the mounting holes on the device line up with the holes on the template.
- 8 If the mounting holes on the device do not line up, mark the new hole locations.
- 9 Based on your mounting method, drill the outer holes on the template:
 - Drill 2.5 mm ($\frac{3}{32}$ in.) pilot holes for the included wood screws, and skip to step 18.
 - Drill 3.5 mm ($\frac{9}{64}$ in.) holes for the included nut plate and machine screws.

- 10** If using the nut plates, starting in one corner of the template, place a nut plate ① over the hole ② drilled in the previous step.

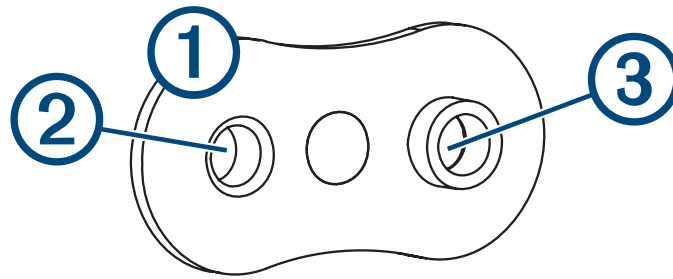

The other hole ③ on the nut plate should line up with the inner 4 mm ($\frac{5}{32}$ in.) hole on the template.

- 11** If the 4 mm ($\frac{5}{32}$ in.) hole on the nut plate does not line up with the inner hole on the template, mark the new location.
- 12** Repeat steps 10 and 11 for each nut plate.
- 13** Using a 4 mm ($\frac{5}{32}$ in.) drill bit, drill the inner holes.
- 14** Remove the template from the mounting surface.
- 15** Starting in one corner of the mounting location, place a nut plate ④ on the back of the mounting surface, lining up the inner and outer holes.
- The raised portion of the nut plate should fit into the inner hole.

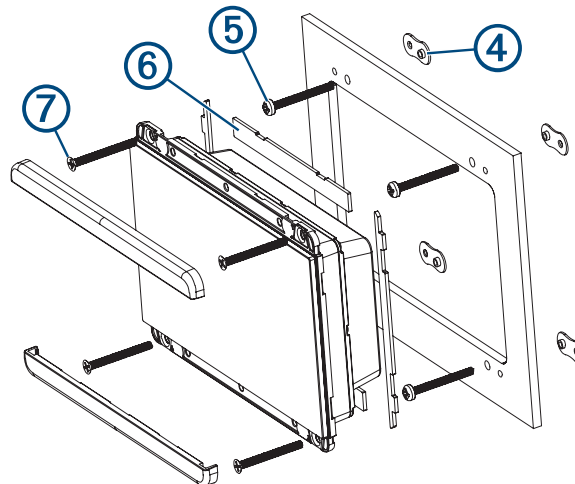

- 16** Secure the nut plate to the mounting surface by fastening an included M3 pan-head screw ⑤ through the inner 4 mm ($\frac{5}{32}$ in.) hole.
- 17** Repeat steps 15 and 16 for each of the nut plates along the top and bottom of the device.
- 18** Install the gasket pieces ⑥ on the back of the device.
- The pieces of the rubber gasket have adhesive on the back. Make sure you remove the protective liner before installing them on the device.
- 19** If you will not have access to the back of the device after you mount it, connect all necessary cables to the device before placing it into the cutout.
- 20** Place the device into the cutout.
- 21** Secure the device to the mounting surface using the included M3 flat-head screws or wood screws ⑦, depending on the mounting method.
- 22** Snap the trim caps into place over the screws.

Connection Considerations

NOTICE

If you are connecting to an **existing** NMEA 2000® network, identify the NMEA 2000 power cable. Only one NMEA 2000 power cable is required for the NMEA 2000 network to operate properly.

A NMEA 2000 Power Isolator (010-11580-00) should be used in installations where the existing NMEA 2000 network manufacturer is unknown.

If you are installing a NMEA 2000 power cable, you must connect it to the boat ignition switch or through another in-line switch. NMEA 2000 devices will drain your battery if the NMEA 2000 power cable is connected to the battery directly.

The helm control must connect to the same NMEA 2000 network as the other autopilot components for the autopilot system to function correctly. The NMEA 2000 network provides power to the helm control and allows for communication with the other autopilot components and from NMEA 2000 devices such as a GPS antenna or a wind sensor.

This device is powered by the NMEA 2000 network, and a separate power connection is not required.

If you are unfamiliar with NMEA 2000, you should read the “NMEA 2000 Network Fundamentals” chapter of the *Technical Reference for NMEA 2000 Products*. To download the reference, go to garmin.com/manuals/nmea_2000.

You can also connect this device to Garmin® Marine Network devices using a 9-pin Garmin Marine Network cable (sold separately). You must use the included adapter to connect to Garmin network devices that have a larger connector. This optional connection is not required for the helm control to function with the autopilot system, but it is recommended for software updates if a Garmin chartplotter is present on the network. This device cannot be updated using only a NMEA 2000 network connection.

See the installation instructions provided in the corepack of your autopilot system for detailed connection information specific to the type of autopilot needed for your boat. This connection diagram shows only the general connection needs of the helm control.

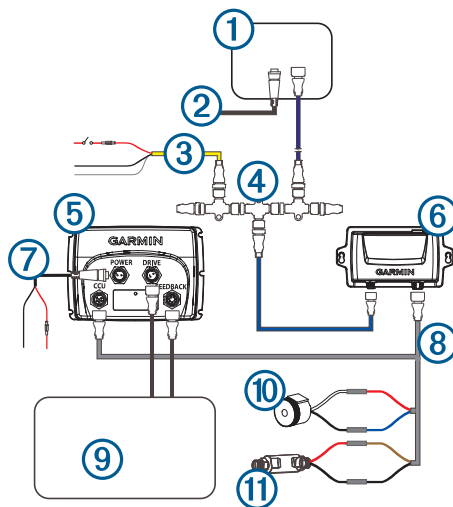

①	GHC 50 helm control
②	Garmin Marine Network cable (recommended for software updates)
③	NMEA 2000 power cable You should install this cable only if you are building a NMEA 2000 network. Do not install this cable if there is an existing NMEA 2000 network on your boat. You must connect the NMEA 2000 power cable to a 9 to 16 Vdc power source.
④	NMEA 2000 network

You must connect the helm control to the same NMEA 2000 network as the other autopilot components using the included T-connectors.
 If there is not an existing NMEA 2000 network on the boat, you can build one using the cables and connectors supplied in the autopilot corepack. See the installation instructions provided in the corepack of your autopilot system for more information.

⑤	Autopilot ECU or SmartPump (hydraulic, mechanical, and SmartPump models) Engine connection (steer-by-wire models)
⑥	Autopilot CCU
⑦	Autopilot ECU or SmartPump power cable (hydraulic, mechanical, and SmartPump models)
⑧	Autopilot CCU cable
⑨	Autopilot pump or drive unit (hydraulic and mechanical models)
⑩	Autopilot Alarm
⑪	Autopilot Shadow Drive™ sensor

Specifications

Dimensions without sun cover (H × W × D)	105 x 140 x 51 mm (4.13 x 5.51 x 2.01 in.)
Dimensions with sun cover (H × W × D)	113 x 144 x 56 mm (4.45 x 5.67 x 2.20 in.)
Weight without sun cover	328 g (11.57 oz.)
Weight with sun cover	375 g (13.23 oz.)
Temperature range	From 5° to 131°F (from -15° to 55°C)
Compass-safe distance	20 cm (7.87 in.)
Case material	Fully-gasketed polycarbonate
Lens material	Glass with an anti-glare and anti-fingerprint finish
Water rating	IEC 60529 IPX7 ¹
Brightness	1200 cd/m ² (NIT)
Typical current draw at 12 Vdc	220 mA
Max. current draw at 12 Vdc	400 mA
Power usage	5.85 W max
NMEA 2000 input voltage	9 to 16 Vdc
NMEA 2000 LEN @ 9 Vdc	13 (650 mA)

¹ The device withstands incidental exposure to water of up to 1 m for up to 30 min. For more information, go to www.garmin.com/waterrating.

联系信息

制造厂商：台湾国际航电股份有限公司

销售厂商：上海佳明航电企业管理有限公司

联络地址：上海市徐汇区桂平路 391 号（新漕河泾国际商务中心 A 座 37 层）

电话：021-60737675

客服专线：400-819-1899

物质宣言

部件名称	有毒有害物质或元素					
	铅	汞	镉	六价铬	多溴联苯	多溴二苯醚
印刷电路板组件	✗	○	○	○	○	○
屏幕/背光	✗	○	○	○	○	○
金属零件	✗	○	○	○	○	○
电缆 电缆组件 连接器	✗	○	○	○	○	○

本表格依据 SJ/T11364 的规定编制。

○：代表此种部件的所有均质材料中所含的该种有害物质均低于 (GB/T26572) 规定的限量

✗：代表此种部件所用的均质材料中，至少有一类材料其所含的有害物质高于 (GB/T26572) 规定的限量

* 该产品说明书应提供在环保使用期限和特殊标记的部分详细讲解产品的担保使用条件。



产品

中国微功率无线电发射设备合规

一) 工作于 2403-2480 MHz 频段的 ANT 技术无线遥控设备，使用频率：2403-2480 MHz, 发射功率限值：10 mW(e.i.r.p), 频率容限：170 kHz

二) 不得擅自改变使用场景或使用条件、扩大发射频率范围、加大发射功率（包括额外加装射频功率放大器），不得擅自更改发射天线；

三) 不得对其他合法的无线电台（站）产生有害干扰，也不得提出免受有害干扰保护；

四) 应当承受辐射射频能量的工业、科学及医疗（ISM）应用设备的干扰或其他合法的无线电台（站）干扰；

五) 如对其他合法的无线电台（站）产生有害干扰时，应立即停止使用，并采取措施消除干扰后方可继续使用；

六) 在航空器内和依据法律法规、国家有关规定、标准划设的射电天文台、气象雷达站、卫星地球站（含测控、测距、接收、导航站）等军民用无线电台（站）、机场等的电磁环境保护区域内使用微功率设备，应当遵守电磁环境保护及相关行业主管部门的规定；

七) 禁止在以机场跑道中心点为圆心、半径 5000 米的区域内使用各类模型遥控器；

八) 微功率设备使用时温度 -15-55°C 直流电压 9-32 Vdc。

© 2022 Garmin Ltd. or its subsidiaries

Garmin® and the Garmin logo are trademarks of Garmin Ltd. or its subsidiaries, registered in the USA and other countries. GHC™ and Shadow Drive™ are trademarks of Garmin Ltd. or its subsidiaries. These trademarks may not be used without the express permission of Garmin.

NMEA 2000® and the NMEA 2000® logo are registered trademarks of the National Marine Electronics Association.

Garmin Corporation

M/N: E3545