



VE.Bus BMS NG

Product manual

Table of Contents

1. Safety precautions	1
2. General description	2
2.1. Features and functionality	3
2.2. What's in the box?	4
3. Installation	5
3.1. System examples	5
3.1.1. Basic system	5
3.1.2. System with a GX device, on/off switch and pre-alarm circuit	6
3.1.3. System with a BatteryProtect and solar charger	7
3.1.4. Three-phase system with a Digital Multi Control	8
3.1.5. System with an alternator	9
3.2. Basic installation	10
3.2.1. Minimal VE.Bus firmware	10
3.2.2. Battery BMS cable connections	11
3.2.3. Mains detector	12
3.3. Controlling DC loads and chargers	13
3.3.1. DC load control	13
3.3.2. DC charge control	13
3.3.3. Controlling inverter/chargers, solar chargers and other battery chargers	13
3.3.4. DVCC operation with VE.Bus BMS NG	14
3.3.5. Charger control via Charge disconnect	14
3.3.6. Charging with an alternator	14
3.4. Remote on/off terminal	14
3.5. GX device	15
3.6. Connecting a Digital Multi Control or a VE.Bus Smart dongle	16
4. Configuration and settings	17
4.1. Configuration of chargers and loads	17
4.2. Power up for the first time	17
4.3. VE.Bus BMS NG and Lithium NG battery settings	18
4.4. Update BMS and Battery firmware	19
4.5. Bluetooth reactivation	19
5. Monitoring and control	21
5.1. Important warning	21
5.2. Monitoring and control via VictronConnect	22
5.3. LEDs, warnings, alarms and error codes	25
6. Frequently asked questions	27
7. Technical specifications VE.Bus BMS NG	28
8. Appendix	29
8.1. Appendix A	29
8.2. Displaying VE.Bus BMS NG SoC on a GX Device	29
8.3. Powering the VE.Bus BMS NG without a connected Multi	30
8.4. Enclosure dimensions VE.Bus BMS NG	32

1. Safety precautions



- Installation must strictly follow the national safety regulations in compliance with the enclosure, installation, creepage, clearance, casualty, markings and segregation requirements of the end-use application.
- Installation must be performed by qualified and trained installers only.
- Carefully study the product manuals of all connected devices before installing them.
- Switch off the system and check for hazardous voltages before altering any connection.
- Do not open the lithium battery.
- Do not discharge a new lithium battery before it has been fully charged first.
- Charge a lithium battery only within the specified limits.
- Install the battery in a vented area.
- Do not mount the lithium battery upside down.
- Do not install batteries in a living area.
- Check if the lithium battery has been damaged during transport.

2. General description

The VE.Bus BMS NG is a Battery Management System (BMS) designed specifically for [Victron Energy Lithium NG batteries](#) (not to be confused with Lithium Smart batteries without NG designation). These are LiFePO₄ batteries available in 12,8 V, 25,6 V, and 51,2 V, and in various capacities.

The VE.Bus BMS NG is intended to interface with and protect Victron Lithium NG batteries in systems that include a Victron VE.Bus inverter/charger or VE.Bus inverter. It relies on this connection to perform key functions such as enabling/disabling charge and discharge based on battery conditions

Batteries can be connected in series, parallel, or a combination of both to build battery banks suitable for 12 V, 24 V, or 48 V system voltages.

- For 12 V and 24 V configurations, up to 50 batteries can be used.
- For 48 V configurations, the maximum is 25 batteries.

This results in a maximum storage capacity of:

- 192 kWh for 12 V systems
- 384 kWh for 24 V systems
- 128 kWh for 48 V systems

For complete specifications, refer to the [Victron Lithium NG battery product page](#).

Cell-level protection

The BMS monitors and protects each individual cell of the connected battery or battery bank. Based on the status signals received from the battery, it will:

- Trigger a pre-alarm to warn of an imminent cell undervoltage
- Disconnect or shut down loads if a cell undervoltage condition occurs
- Turn off the inverter in VE.Bus inverter/chargers or VE.Bus inverters in case of cell undervoltage
- Reduce charge current if a cell overvoltage or overtemperature is detected in VE.Bus inverter/chargers or VE.Bus inverters
- Disconnect or shut down chargers in case of cell overvoltage or overtemperature

2.1. Features and functionality

• Bluetooth Smart

- The VE.Bus BMS NG has built-in Bluetooth Smart, enabling wireless configuration, monitoring, and firmware updates via Apple and Android smartphones, tablets, or other compatible devices. Various parameters can be adjusted using the [VictronConnect App](#).
- This also includes Instant Readout, allowing key BMS and battery data - SoC, battery temperature, warnings, and alarms - to be displayed on the VictronConnect device list without needing to connect to the product.

• Load Disconnect output

- Controls the remote on/off input of a [BatteryProtect](#), [Inverters](#), [DC-DC converter](#), or other loads with remote on/off functionality.
- The output is normally high, becomes free-floating when cell undervoltage is imminent. Maximum output current: 1A (not short-circuit protected).
Note that a non-inverting or inverting on/off cable may be required (see [Appendix A \[29\]](#)).

• Charge disconnect output

- Controls the remote on/off port of chargers such as the [Smart Charger IP43](#), a [Cyrix-Li-Charge relay](#), a [Cyrix-Li-ct Battery Combiner](#) or a [BatteryProtect](#). Note that the Charge disconnect output is not suitable to power an inductive load such as a relay coil.
- The output is normally high, becomes free-floating in case of imminent cell overvoltage or overtemperature. Maximum output current: 500mA (not short-circuit protected).

• Remote on/off terminal

- Allows remote control of the Load and Charge Disconnect outputs. When off, both outputs become free-floating, turning off connected loads and chargers.
- Consists of two terminals: Remote L and Remote H.
- Can be operated using:
 - A switch or relay contact between L and H.
 - H switched to battery plus or L switched to battery minus.



An on/off switch or the default wire loop must be installed for correct operation.

• Pre-alarm output

- Triggers a visible or audible warning when battery voltage is low, activating at least 30 seconds before the Load Disconnect output is disabled due to cell undervoltage.
- Can drive a relay, LED, or buzzer. Maximum output current: 1A (not short-circuit protected).
- The output is normally free-floating, becomes high in case of imminent cell undervoltage.

• Configurable discharge floor

- Defines the minimum SoC to prevent excessive discharge and ensure enough energy remains for self-discharge after a low SoC shutdown.
- A low SoC warning level can be set, triggering a warning in VictronConnect that the discharge floor is about to be reached. The pre-alarm output is activated as soon as the warning level is reached. The value should be set high enough to leave enough time to recharge the battery to prevent a low SoC shutdown.
- A low SoC alarm is triggered when the discharge floor is reached, and the BMS immediately deactivates the ATD output, effectively shutting off any loads it controls.

• LED indicators

- **Blue Bluetooth Status LED:**
- **Red Error LED:**
- **VE.Bus Status LED:**

• Connectivity and communication with GX device

- On/off/charger-only control of VE.Bus products via a GX device.

- GX DVCC control of solar chargers. There is no need to install an BatteryProtect or Cyrix-Li-Charge to control solar chargers via the BMS like the VE.Bus BMS V1 does.
- **Has separate power input and output connections for GX devices**
 - The GX-Pow output provides power to the GX device from either the battery or the Aux-In input, depending on which voltage is higher.
- **True remote on/off terminal**
 - The VE.Bus BMS NG needs to remain connected to the battery positive in order to be able to keep the Multi in low power mode even when AC input on the Multi is available (Multi will stop inverting/charging, close the transfer switch and indicate a low battery error on the status LEDs).
- **Optional auxiliary power for remote access**
 - For users who want to ensure continued remote access via VRM even when the system is otherwise shut down (e.g. due to a battery undervoltage or inverter/charger shutdown), an AC-DC adapter (not provided by Victron) or other power supply can be connected to the Aux-In input. This keeps the GX device powered as long as auxiliary power is available, allowing for remote diagnostics if internet connectivity is still present. See the [Technical specifications VE.Bus BMS NG \[28\]](#) for the required power rating of an AC-DC adapter.

2.2. What's in the box?

The following items are in the box:

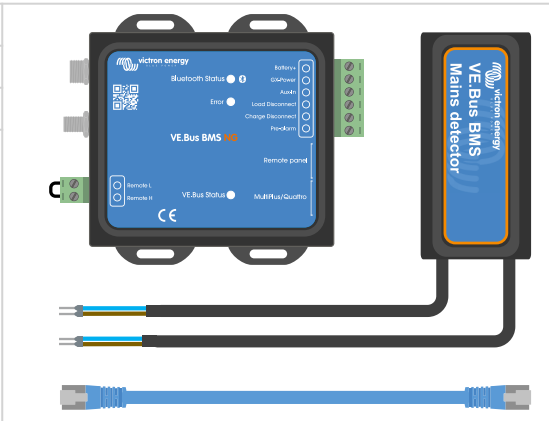
1x VE.Bus BMS NG	
1x Mains detector	
1x 0.3m RJ45 UTP cable	
Piece of Velcro adhesive hook and loop tape	

Note that the DC power cable to power the BMS is not included. Use any 1-wire cable with at least 0.75mm² (AWG 16) and a 1A inline fuse.

3. Installation

3.1. System examples

3.1.1. Basic system

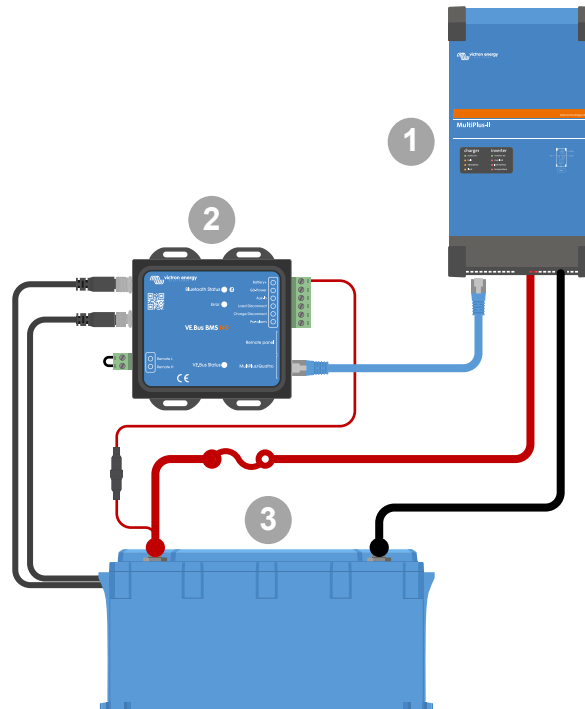

#	Description
1	MultiPlus-II Inverter/charger
2	VE.Bus BMS NG
3	Lithium NG Battery or battery consisting of multiple batteries creating a 12V, 24V or 48V battery bank

3.1.2. System with a GX device, on/off switch and pre-alarm circuit

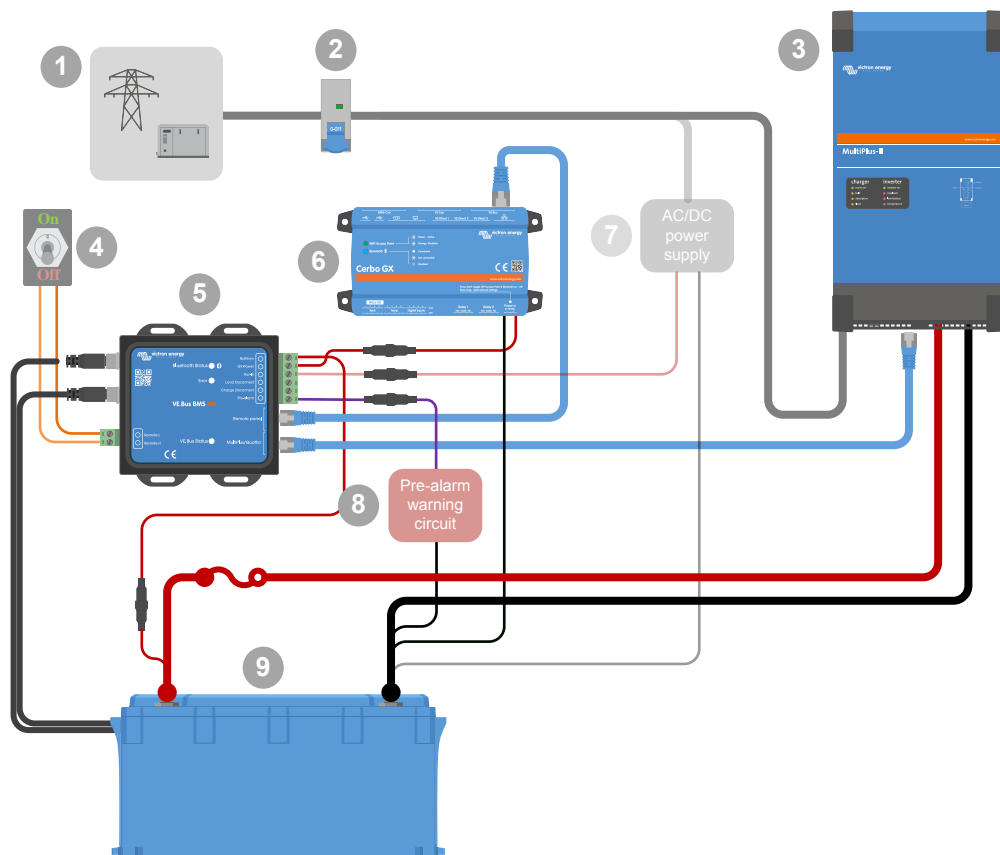

#	Description
1	AC source, grid or generator
2	Circuit breaker
3	MultiPlus-II Inverter/charger
4	Remote on/off switch
5	VE.Bus BMS NG
6	Cerbo GX
7	Optional AC-DC power supply keeps the GX device powered as long as auxiliary power is available, even if the system is otherwise shut down (e.g. due to a battery undervoltage or inverter/charger shutdown).
8	Pre-alarm warning circuit, giving an advanced warning in case of an imminent system shutdown due to a too far discharged battery
9	Lithium NG Battery or battery consisting of multiple batteries creating a 12V, 24V or 48V battery bank

3.1.3. System with a BatteryProtect and solar charger

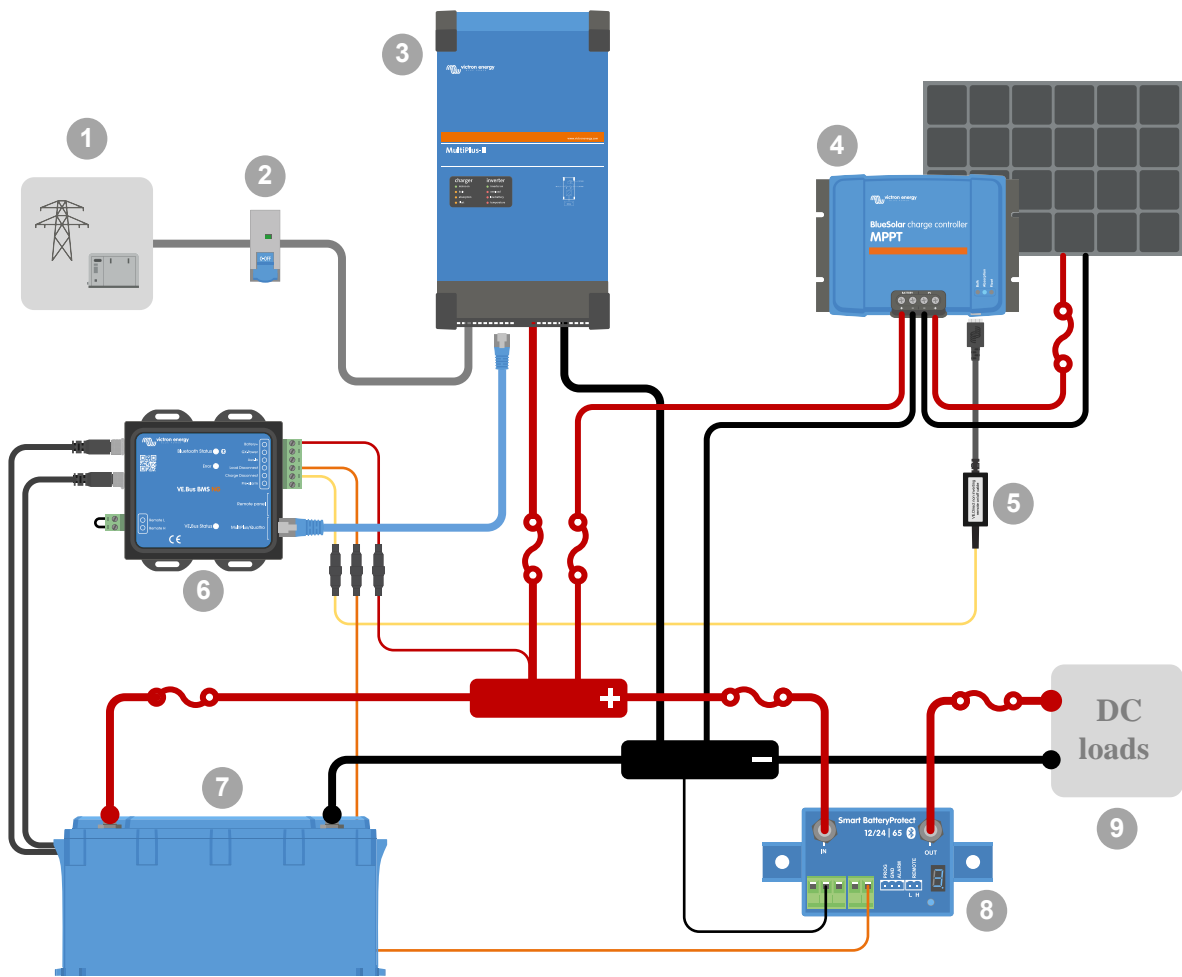

#	Description
1	AC source, grid or generator
2	Circuit breaker
3	MultiPlus-II Inverter/charger
4	Solar charger
5	VE.Direct non-inverting remote on/off cable connects between the solar charger VE.Direct port and the BMS Charge disconnect terminal
6	VE.Bus BMS NG
7	Lithium NG Battery or battery consisting of multiple batteries creating a 12V, 24V or 48V battery bank.
8	BatteryProtect
9	DC loads

3.1.4. Three-phase system with a Digital Multi Control

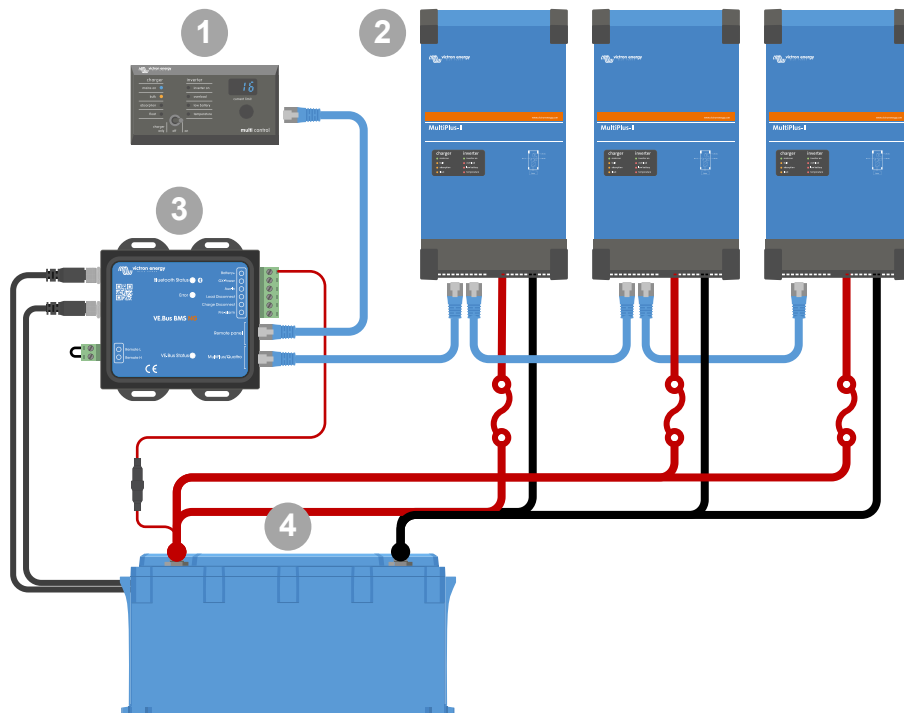

#	Description
1	Digital Multi Control
2	MultiPlus-II Inverter/charger installed and configured as a 3-phase system
3	VE.Bus BMS NG
4	Lithium NG Battery or battery consisting of multiple batteries creating a 12V, 24V or 48V battery bank

3.1.5. System with an alternator

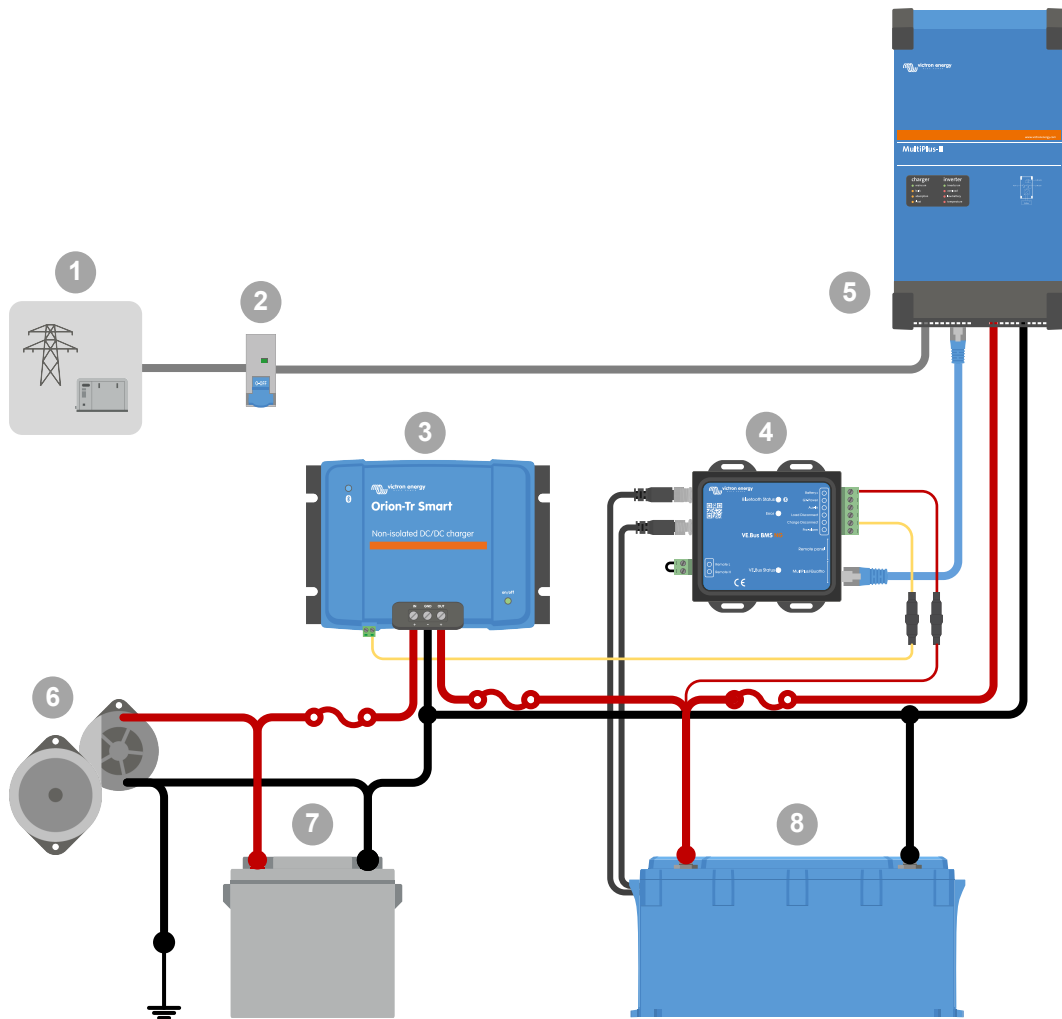

#	Description
1	AC source, grid or generator
2	Circuit breaker
3	Orion DC-DC charger, the remote H terminal is connected to the Charge disconnect terminal on the VE.Bus BMS NG
4	VE.Bus BMS NG
5	MultiPlus-II Inverter/charger
6	Starter monitor and alternator
7	12V starter battery
8	Lithium NG Battery or battery consisting of multiple batteries creating a 12V or 24V battery bank

3.2. Basic installation

1. Connect the battery BMS cables to the BMS. For multiple batteries, see the [Battery BMS cable connections \[11\]](#) chapter. Be sure to read and follow the installation instructions in the [Lithium NG Battery manual](#).
2. Connect the inverter/charger or inverter positive and negative cables to the battery. Make sure it has been updated to the most recent firmware version. For more information, see the [Minimal VE.Bus firmware \[10\]](#) chapter.
3. Connect the battery positive via the red power cable with the fuse to the BMS "Battery+" terminal.
4. Connect the VE.Bus port of the Inverter/charger or inverter to the "MultiPlus/Quattro" port of the BMS using the included RJ45 cable.
5. In case of a [new style MultiPlus 12/1600/70](#), [new style MultiPlus 12/2000/80](#), MultiPlus-II or Quattro-II, don't install the mains detector. For more information, see the [Mains detector \[12\]](#) chapter.

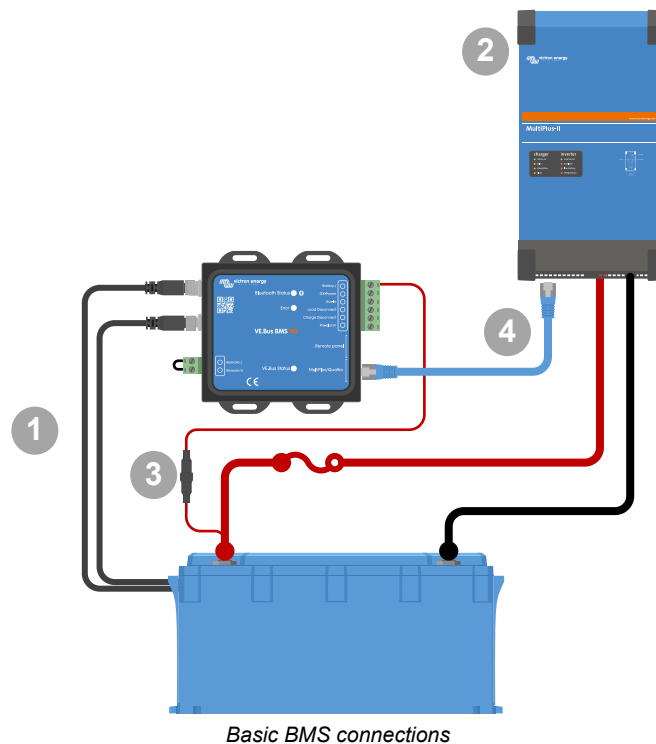

Note that the BMS does not have a battery negative connection. This is because the BMS obtains battery negative from the VE.Bus. As such, the BMS cannot be used without a VE.Bus Inverter/charger or a VE.Bus inverter.

3.2.1. Minimal VE.Bus firmware



Incompatibility Warning: Inverter/chargers or inverters with the small processors labeled 19XXXXX or 20XXXXX are not supported. These can be identified by the first two digits on the microprocessor label. For such devices, use the VE.Bus BMS together with Lithium Smart batteries instead of the VE.Bus BMS NG and Lithium NG batteries.

Important: Firmware requirements before connecting the BMS

1. **Update VE.Bus firmware:** Ensure that all inverter/chargers or inverters used in the system have their VE.Bus firmware updated to version xxxx489 or higher.
2. **Firmware between xxxx415 and xxxx489:** If the firmware is between xxxx415 and xxxx489, you must install either the VE.Bus BMS or ESS assistant on the inverter/charger.
3. **Firmware below xxxx415:** Devices with firmware versions below xxxx415 will trigger a VE.Bus error 15 (VE.Bus combination error), indicating that the VE.Bus products or firmware versions are incompatible. If the firmware cannot be updated to version xxxx415 or higher, the VE.Bus BMS NG cannot be used.

3.2.2. Battery BMS cable connections

In the case of several batteries in parallel and/or series configuration, the BMS cables should be connected in series (daisy-chained), and the first and last BMS cable should be connected to the BMS.

If the BMS cables are too short, they can be extended with extension cables, the [M8 circular connector Male/Female 3 pole cables](#).

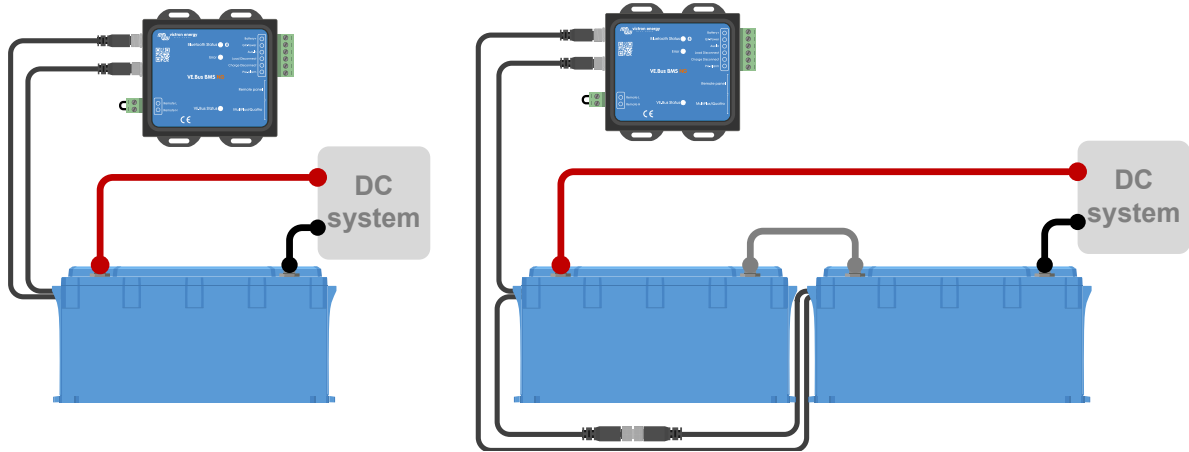

Left: Connecting a single battery. Right: connecting multiple batteries.

3.2.3. Mains detector

i The mains detector is not required for the **new style MultiPlus 12/1600/70** and **MultiPlus 12/2000/80**, MultiPlus-II, Quattro-II and inverter models. In this case, these chapters can be skipped, and the mains detector should be disposed of.

The purpose of the mains detector is to restart the inverter/charger when the AC supply becomes available in case the BMS has shut down the inverter/charger due to low cell voltage (so that it can recharge the battery).

In systems consisting of several units configured for parallel, three-phase, or split-phase operation, the mains detector should be wired in the master or leader unit only.

In the case of a MultiPlus, only use one AC wire pair, and in the case of a Quattro, use both wire pairs.

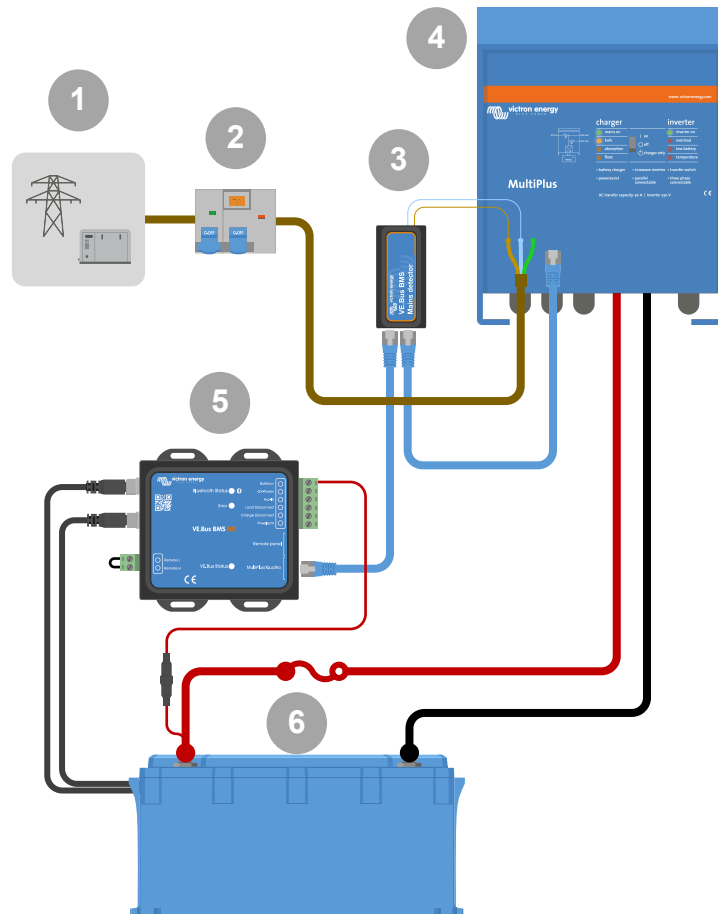

AC detector wiring example.

#	Description
1	AC grid or generator
2	AC circuit breaker and RCD
3	Mains detector
4	Inverter/charger
5	VE.Bus BMS NG
6	Lithium NG Battery

3.3. Controlling DC loads and chargers

3.3.1. DC load control

DC loads with remote on/off terminals:

DC loads must be switched off or disconnected to prevent cell undervoltage. The Load disconnect output of the BMS can be used for this purpose. The Load disconnect output is normally high (= battery voltage). It becomes free-floating (= open circuit) in case of an impending cell undervoltage (no internal pull down to limit residual current consumption in case of low cell voltage).

DC loads with a remote on/off terminal that switches the load on when the terminal is pulled high (to battery plus) and switches it off when the terminal is left free-floating, can be controlled directly with the BMS Load disconnect output.

DC loads with a remote on/off terminal that switches the load on when the terminal is pulled low (to battery minus) and switches it off when the terminal is left free-floating, can be controlled with the BMS Load disconnect output via an [Inverting remote on/off cable](#).



Note: please check the residual current of the load when in the off state. After low cell voltage shutdown, a capacity reserve of approximately 1Ah per 100Ah battery capacity is left in the battery. For example, a residual current of 10mA can already damage a 200Ah battery if the system is left in a discharged state for more than eight days.

Disconnecting a DC load via a BatteryProtect:

Use a BatteryProtect for DC loads that do not have a remote on/off terminal or for switching groups of DC loads off.

A BatteryProtect will disconnect the DC load when:

- Its input voltage (= battery voltage) has decreased below a preset value.
- Its remote on/off H terminal becomes free floating (usually high). This signal is provided by the Load disconnect output (wired to the remote on/off H terminal of the BatteryProtect) of the VE.Bus BMS NG. See the wiring example [System with a BatteryProtect and a solar charger](#).

3.3.2. DC charge control

3.3.3. Controlling inverter/chargers, solar chargers and other battery chargers

In the event of high cell voltage or low temperature, battery charging must be stopped to protect the battery cells. Depending on the system, chargers are either controlled via DVCC or must be controlled via their remote on/off terminals and the Charge disconnect output of the VE.Bus BMS NG.

- In systems with a GX device, you must enable DVCC to ensure that the solar chargers and other DVCC-compatible devices only charge when they should. See [DVCC operation with VE.Bus BMS NG \[14\]](#) for details.
- In systems without a GX device, the BMS Charge disconnect output must control the solar charger and other chargers, either via remote on/off, a BatteryProtect or a Cyrix-Li-Charge. See [Charger control via Charge disconnect \[14\]](#) for details.

3.3.4. DVCC operation with VE.Bus BMS NG

DVCC (Distributed Voltage and Current Control) allows a GX device to control compatible devices such as solar chargers, Inverter RS, Multi RS or Multis.

In order for the GX device to control the solar chargers, Inverter RS or Multi RS in a system with a VE.Bus BMS NG, DVCC **must** be enabled. These chargers are controlled by setting their maximum charge current limit to zero when the VE.Bus BMS NG requests that charging should stop.

Note that the presence of a VE.Bus BMS NG does not control the charge voltage of the solar chargers, Inverter RS, Multi RS or a Multi.

- In an ESS system, the Multi controls the charging voltage of the solar chargers, Inverter RS and Multi RS using the configuration made with VE.Configure or VictronConnect. In other words: The charge algorithm must be configured in the Multi.i
- In a non-ESS (off-grid) system, the solar chargers, Inverter RS, Multi RS and Multi follow their own internal charge algorithm. Here, all devices must be set to the appropriate lithium charge algorithm.

AC chargers and smaller inverters are not (yet) controlled by the GX device, and therefore you still need to wire signal wiring (via ATC aka Charge disconnect) to control such devices.

3.3.5. Charger control via Charge disconnect

Chargers that are not DVCC compatible or installed in systems without a GX device can be controlled via the VE.Bus BMS NG Charge disconnect output, provided the chargers have a remote on/off port.

The Charge disconnect output, normally high (equal to battery voltage), must be connected to the H terminal of the charger's remote on/off connector. At high cell voltage or low temperature, the Charge disconnect output becomes free-floating and pulls the charger's remote on/off H terminal low (to battery minus), stopping the charge.

For battery chargers with a remote terminal that activates the charger when the terminal is pulled low (to battery minus) and deactivates when the terminal is left free floating, the [Inverting remote on-off cable](#) can be used.

Alternatively, a [Cyrix-Li-Charge relay](#) can be used. The Cyrix-Li-Charge relay is a unidirectional combiner that inserts between a battery charger and the lithium battery. It will engage only when charge voltage from a battery charger is present on its charge-side terminal. A control terminal connects to the Charge disconnect output of the BMS.

3.3.6. Charging with an alternator

Alternator charging can be controlled either with a DC-DC charger such as the [Orion-Tr Smart](#), or with a [SolidSwitch 104](#) when controlling an external alternator regulator like the Balmar MC-614.

Both devices are then also controlled by the BMS Charge disconnect output wired to the Orion-Tr Smart or SolidSwitch 104 remote on/off H terminal. See [Charging with an alternator \[14\]](#)

3.4. Remote on/off terminal

The BMS remote on/off terminal can be used to turn the entire system on and off while the BMS remains connected to battery positive, which keeps the inverter in low power (discharging and charging not allowed) mode even if it is still connected to AC In.

The remote H and L terminals switch the system on when:

- Contact is made between the remote H terminal and L terminal, for example, via the wire bridge or a switch.
- Contact is made between the remote connector H terminal and battery positive.
- Contact is made between the remote connector L terminal and battery negative.

A typical application is switching off the system when a predetermined state of charge (SoC) is reached in a BMV. Its relay then operates the remote on/off terminal of the BMS. Note that at least the wire loop between pins L and H must be plugged in, so that the VE.Bus BMS NG can switch on.

3.5. GX device

For solar chargers, Inverter RS, Multi RS or Multis to be controlled by the BMS via a GX device, the following requirements should be met:

- The GX device Venus OS firmware must be version 2.80 or above.

Installation:

1. Connect the GX device VE.Bus port to the Remote panel port on the BMS via an RJ45 cable (not included). Note that this is different from the former VE.Bus BMS V1, which allowed only the connection of a Digital Multi Control. The VE.Bus BMS NG allows to connect a GX device, a VE.Bus Smart dongle or a Digital Multi Control.
2. Connect the GX device "power +" terminal to the GX-Pow terminal of the BMS and connect the GX device "power -" terminal to the negative terminal of the battery.
3. Connect the positive wire of an (optional) AC-DC power supply to the AUX-in terminal of the BMS and connect the negative wire to the negative battery terminal. Note that the AC-DC power supply is optional and most likely not needed in off-grid installations such as boats or RVs.
4. Perform a VE.Bus re-detect system action on the GX device. This action is available in the inverter/charger menu on the GX device.
5. To display VE.Bus BMS NG SoC on a GX device, see [section 8.2. - Displaying VE.Bus BMS NG SoC on a GX device.](#) [29]

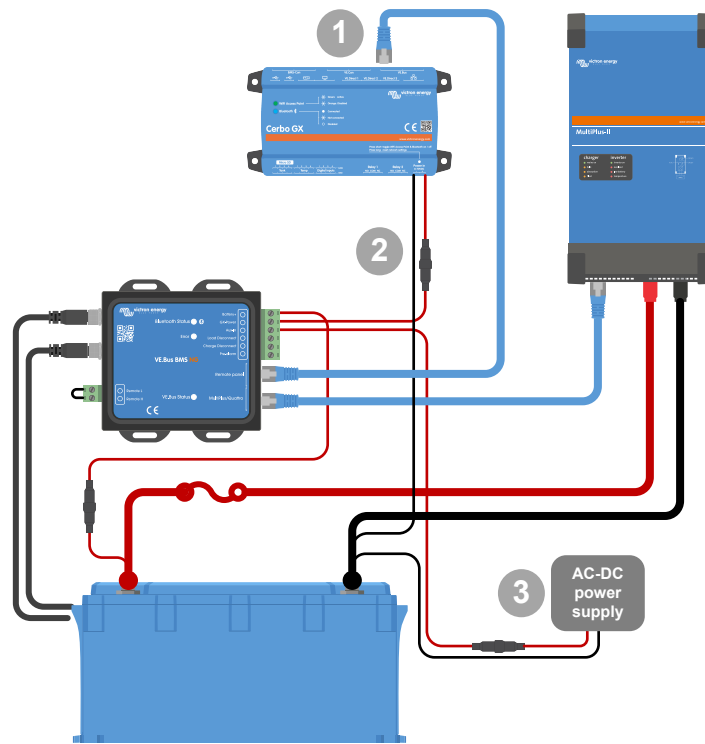

GX device connections

Functionality of the GX-Pow and Aux-In terminals:

- The GX-Pow output supplies GX power from either the battery or from the Aux-In input, whichever voltage is higher.

The GX device is normally powered via the GX-Pow terminal, which in turn is supplied by the Battery+ connection. In the event of a low cell voltage, this battery supply may no longer be available, causing the GX device to shut down.

To maintain GX device operation during such conditions, an optional AC-DC power supply (not supplied by Victron) can be connected to the Aux-In input. If present, this auxiliary source ensures the GX device remains powered as long as the Aux-In voltage is available, for example, enabling remote access and diagnostics via VRM even if the rest of the system is offline.

3.6. Connecting a Digital Multi Control or a VE.Bus Smart dongle

If you intend to use a [VE.Bus Smart dongle](#) or [Digital Multi Control](#) (DMC), it must be connected to the Remote panel port of the BMS. Both have on/off/charger-only control of the inverter/charger. It is also possible to connect the [Inverter Control](#) panel in case a VE.Bus inverter is used.

Note that in systems containing a Digital Multi Control and a GX device or a VE.Bus Smart dongle at the same time, on/off/charger-only control of the inverter/charger is only possible via the Digital Multi Control.

For example, the VE.Bus Smart dongle, Digital Multi Control and the GX device can all be connected simultaneously to the Remote panel port. However, in this scenario, on/off/charger-only control of the inverter/charger via the GX device and VE.Bus Smart dongle is disabled. Since inverter/charger control is disabled, the GX device or VE.Bus Smart dongle can also be connected to the MultiPlus/Quattro port of the BMS for easy wiring.

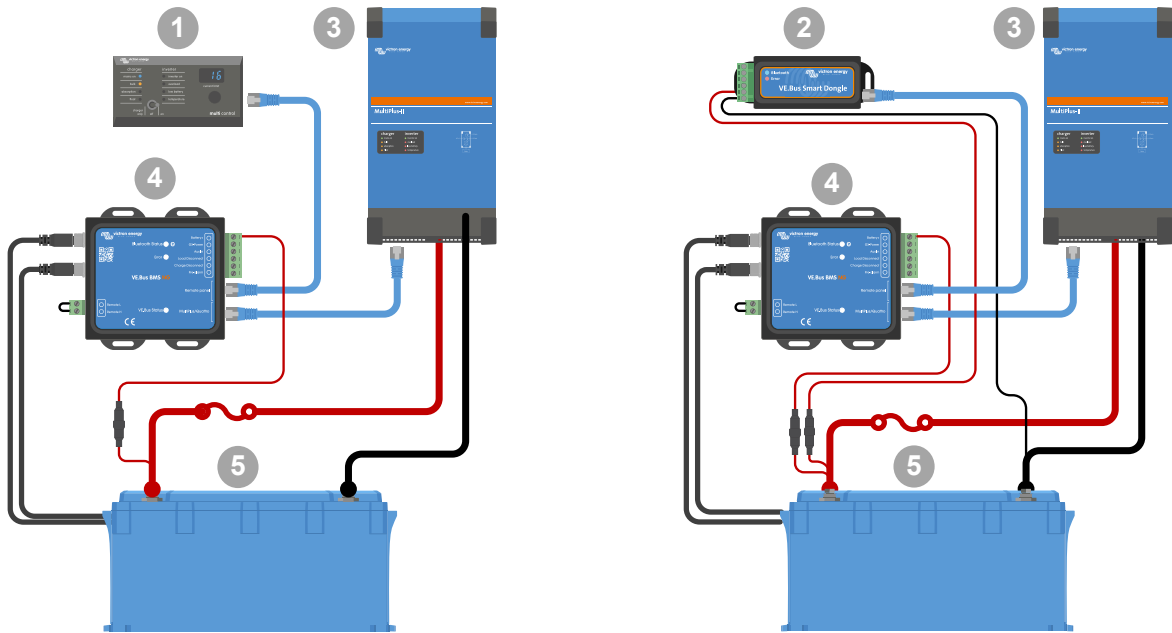

Left: System with a Digital Multi Control Panel - Right: System with a VE.Bus Smart dongle

#	Description
1	Digital Multi Control (or Inverter Control in case a VE.Bus inverter is used)
2	VE.Bus Smart dongle
3	MultiPlus-II Inverter/charger
4	VE.Bus BMS NG The VE.Bus Smart dongle needs to measure the battery voltage. Therefore its Battery+ terminal must be connected to the positive battery terminal. Be aware that the VE.Bus Smart dongle will not be turned off by the BMS in case of a low cell warning and will continue to draw current (up to 9mA - see the VE.Bus Smart dongle specifications for details) from the battery.
5	Lithium NG Battery which can consist of multiple batteries to form a 12V, 24V or 48V battery.

4. Configuration and settings

4.1. Configuration of chargers and loads

Before turning on the system, ensure that chargers and loads are correctly configured, particularly their maximum combined charge and combined discharge currents, to avoid exceeding battery limits.

Maximum charge current

The maximum continuous charge current is 1C. The maximum pulse charging current depends on the battery model. Please refer to the [Lithium NG battery datasheet](#) for details.



For optimal battery performance, a charge current of 0.3C is recommended.

Maximum discharge current

The maximum continuous discharge current is 1C. The maximum pulse discharge current is 2C for a maximum of 10 seconds.



For optimal battery performance, a discharge current of 0.5C is recommended.



Chargers and loads not controlled by the BMS (via ATC and ATD) can permanently damage the battery.

Maximum battery charge- and discharge currents for 12.8V Lithium NG batteries

	12.8/100	12.8/150	12.8/200	12.8/300
Max continuous discharge current	100A	150A	200A	300A
Max pulse discharge current (10s)	200A	300A	400A	600A
Max continuous charge current	100A	150A	200A	300A
Max pulse charge current (10s)	200A	225A	400A	450A

Maximum battery charge- and discharge currents for 25.6V and 51.2V Lithium NG batteries

	25.6/100	25.6/200	25.6/300	51.2/100
Max continuous discharge current	100A	200A	300A	100A
Max pulse discharge current (10s)	200A	400A	600A	200A
Max continuous charge current	100A	200A	300A	100A
Max pulse charge current (10s)	200A	400A	450A	200A

4.2. Power up for the first time

The VE.Bus BMS NG switches on when the following conditions are met:

- Battery connection:** The Bat+ of the 6-pin terminal block must be connected to Battery Plus.
- VE.Bus inverter/charger connection:** The RJ45 labelled MultiPlus/Quattro port must be connected to a VE.Bus inverter/charger or VE.Bus inverter. This connection is essential, as the BMS derives its battery negative through the VE.Bus link.

The VE.Bus BMS assistant no longer needs to be configured via VEConfigure. This is done automatically as soon as a connection between the VE.Bus device and the BMS is established.

4.3. VE.Bus BMS NG and Lithium NG battery settings

Once powered up, use the VictronConnect app to configure the BMS settings.

Some values such as battery capacity, voltage, and the number of batteries (in total, in series, and in parallel) are automatically detected and cannot be edited. However, they should still be verified for accuracy.

Battery monitor settings:

Unlike other battery monitors, the VE.Bus BMS NG has mostly fixed parameters. This is because it is designed specifically for use with Victron Lithium NG batteries, where key settings are predefined.

- **Charged voltage:** Voltage above which the battery monitor resets SoC to 100%, if tail current and charged detection time are also met.
- **Tail current:** Current below which SoC is reset to 100%, if charged voltage and charged detection time conditions are met. Default: 4% (adjustable)
- **Charged detection time:** Time the charged voltage and tail current must be maintained to trigger synchronisation. Default: 3 minutes (adjustable)
- **Low SoC warning level:** Level at which a warning is issued before the discharge floor has been reached. Default: 12 % (adjustable)
The pre-alarm output is activated and a warning is displayed in VictronConnect when the warning is active.
- **Discharge floor:** Default: 10% (adjustable). This parameter has two functions:
 - Its primary use is to set the minimum SoC to determine how far the battery may be discharged and to ensure that there is enough energy left for self-discharge after the battery is no longer allowed to discharge (Allowed to discharge = No).

A restricted depth of discharge extends battery life and provides backup power, e.g., for solar systems until sunrise.

When the discharge floor is reached, a low SoC alarm is triggered, and ATD is disabled.

Setting the discharge floor to zero (not recommended) disables this feature.



The discharge floor prevents full discharge and should be set to retain enough energy for self-discharge until recharging is possible.

- It determines the 'Time remaining' value in the VictronConnect app, calculated based on the actual discharge current and the set discharge floor.
- **State of charge:** Allows manual setting of the current SoC.
- **Synchronise SoC to 100%:** Manually synchronise SoC to 100%.

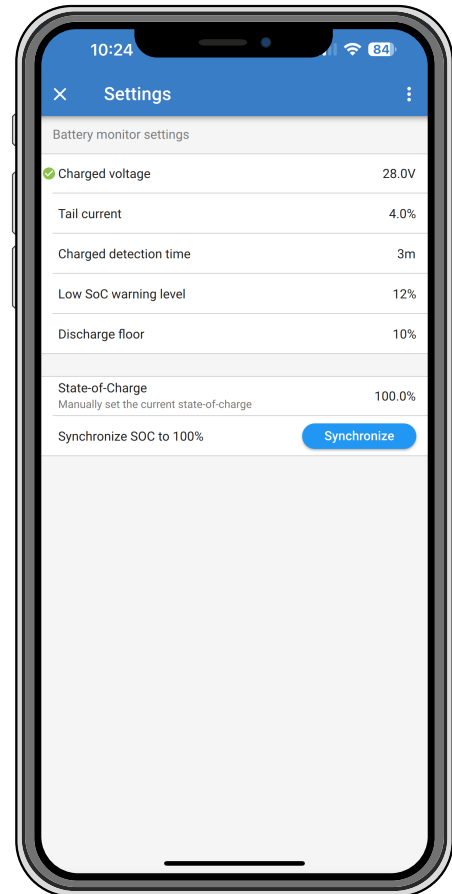

4.4. Update BMS and Battery firmware

Updating the VE.Bus BMS NG firmware can be carried via the VictronConnect app.

General notes on firmware updates

- **Newer isn't always better** – only update if necessary.
- **If it works, don't break it** – avoid unnecessary updates.
- **Read the changelog first** – available on [Victron Professional](#).

Use this feature with care. Our main advice is not to update a running system unless problems occur or before the first startup.

Notes on updating the VE.Bus BMS NG and Lithium NG battery firmware

- The firmware update does not cause a full system shutdown.
- During the update, the Charge disconnect output opens, preventing battery charging.
- If the update fails, the Load disconnect output will open after 120 seconds as a safety measure, allowing time to retry the update.

Updating the firmware

1. For detailed instructions, refer to the [firmware update](#) chapter in the VictronConnect manual.
2. If a newer firmware version is available, VictronConnect (ensure you are using the latest app version) will notify you automatically once a connection with the VE.Bus BMS NG is established.

Which firmware version do I have?

The firmware version is visible on the VictronConnect Product info page of the BMS.

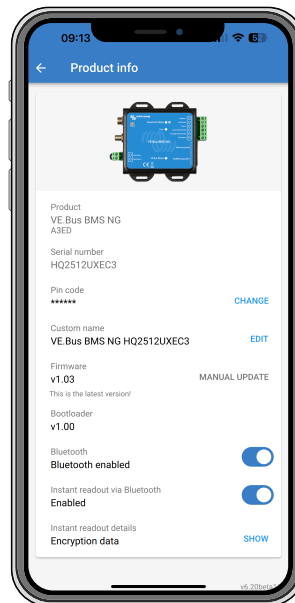

4.5. Bluetooth reactivation

If Bluetooth has been deactivated for the BMS in VictronConnect, for example for security reasons, it can be reactivated as follows:

1. Switch the BMS off and on again.
2. After power-up, Bluetooth will remain enabled for approximately 30 seconds.
3. Open VictronConnect within this time and connect to the BMS.
4. Go to the product information page.
5. Re-enable Bluetooth to keep it active.

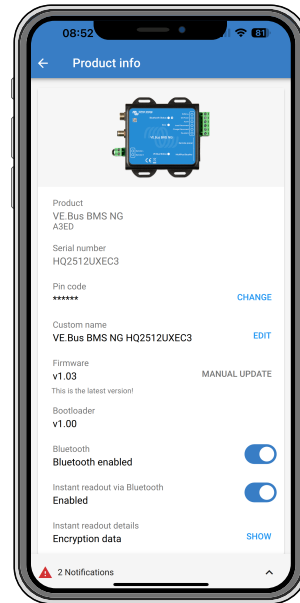

5. Monitoring and control

5.1. Important warning



Lithium batteries are expensive and can be damaged due to over-discharge or overcharge.

The shutdown by the BMS due to low cell voltage should always be used as a last resort to be safe at all times. We recommend not letting it get that far and instead either switching off the system automatically after a defined state of charge via the BMS discharge floor limit so that there is always sufficient reserve capacity in the battery or using the BMS remote on/off port as a system on/off switch.

Damage due to over-discharge can occur if small loads (such as alarm systems, relays, standby currents of certain loads, back current drain of battery chargers, or charge regulators) slowly discharge the battery when the system is not in use.

In case of any doubt about possible residual current draw, isolate the battery by opening the battery switch, pulling the battery fuse(s) or disconnecting the battery plus when the system is not in use.

A residual discharge current is especially dangerous if the system has been discharged completely and a low cell voltage shutdown has occurred. After shutdown due to low cell voltage, a capacity reserve of approximately 1Ah per 100Ah battery capacity is left in the battery. The battery will be damaged if the remaining capacity reserve is drawn from the battery; for example, a residual current of just 10mA can damage a 200Ah battery if the system is left discharged for more than 8 days.

If a low cell voltage disconnect has occurred, immediate action (recharge the battery) is required.

5.2. Monitoring and control via VictronConnect

The battery and BMS are monitored and controlled using the VictronConnect app.

VictronConnect has three pages for this purpose: a status page, a battery page and a history page. The individual parameters are explained below.

Status page:

The status page provides information about the current battery and BMS status.

- **State of Charge:** Shows the battery charge level in percent.
- **Mode:** Displays the system status (On or Off) and allows powering off the system with a tap.
- **Allowed to charge:** Shows the BMS status for Allowed to charge. Reasons why the status shows "No" are as follows:
 - Battery temperature below 5 °C.
 - Battery temperature too high.
 - One or more battery cell voltages have reached the high cell voltage threshold (hardcoded in the battery).
 - Disabled via Remote on/off input.
- **Allowed to discharge:** Shows the BMS status for Allowed to discharge. Reasons why the status shows "No" are as follows:
 - The configured Discharge floor has been reached.
 - One or more cells reached the hard-coded low cell voltage threshold.
 - Disabled via Remote on/off input.

Note that "Allowed to discharge" will show "Pre-Alarm" in the event of a pre-alarm.

- **Voltage:** The battery voltage as reported by the battery.
- **Current:** The battery current that is currently flowing, as reported by the battery.
- **Power:** The battery power as reported by the battery.
- **Consumed Ah:** Consumed Ah since last full charge cycle.
- **Time remaining:** The time that remains at current consumption until the defined [Discharge floor](#) is reached.

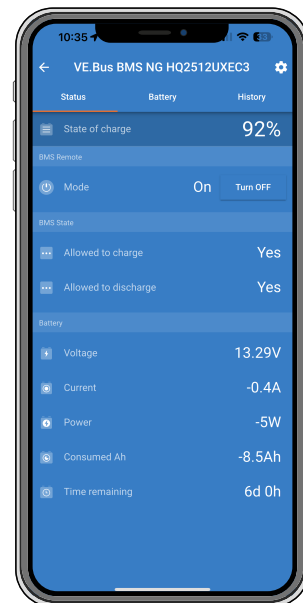
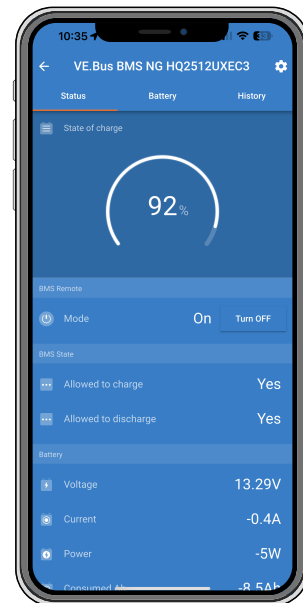

Battery page:

The battery page provides information about the installed battery bank and gives more detailed information about each individual battery.

Battery bank info

- **Balancer status:** Shows the battery balancer status. Possible states are:
 - **Unknown:** The current balancer status is unknown. Reasons for this could be:
 - The battery has not been fully charged for more than 30 days.
 - The battery has just been added to the system.
 - State of charge is unknown.
 In all cases, start a new charging cycle.
 - **Balanced:** All battery cells are well balanced.
 - **Imbalanced:** An imbalance has been detected between one or more battery cells. Start a full charge cycle to balance the battery.
 - **Balancing:** The battery is currently charging and the cells are being balanced.
- **Min cell voltage:** Displays the lowest cell voltage detected in the battery.
- **Max cell voltage:** Displays the highest cell voltage detected in the battery.
- **Min cell temperature:** Displays the lowest cell temperature detected in the battery.
- **Max cell temperature:** Displays the highest cell temperature detected in the battery.
- **Batteries:** Number of batteries installed in the system. This is automatically recognised by the BMS.
- **Battery cells:** Number of battery cells in total. This is automatically recognised by the BMS.
- **Batteries in series:** Number of batteries connected in series configuration. This is automatically recognised by the BMS.
- **Batteries in parallel:** Number of batteries connected in parallel configuration. This is automatically recognised by the BMS.

Individual battery info

The lower half of the battery page contains specific information about the selected battery. If there is more than one battery installed, the respective battery can be selected using the "Battery number" selector.

- The information for each individual battery is: battery serial number, nominal capacity, firmware version, battery temperature, battery voltage, battery current, individual cell voltages.

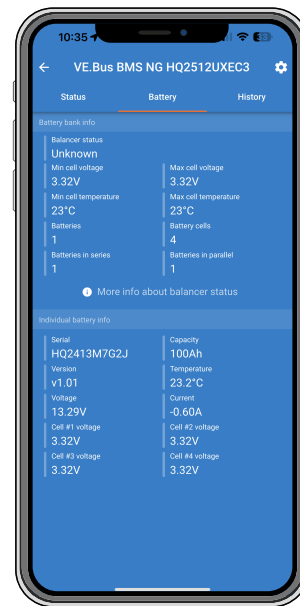

History page:

The history page shows information about the battery over time since installation or since the history was last reset.

- **Deepest discharge:**
- **Cumulative AH drawn:**
- **Discharged energy:**
- **Charged energy:**
- **Synchronisations:**
- **Cycles:**
- **Last full charge:**
- **Minimum battery voltage:**
- **Maximum battery voltage:**
- **Min cell voltage:**
- **Max cell voltage:**
- **Min battery temperature:**
- **Max battery temperature:**



5.3. LEDs, warnings, alarms and error codes

The BMS is equipped with three LEDs: the Bluetooth Status LED, the Error LED, and the VE.Bus Status LED. These indicate the current operating state as well as any faults.

- Warning, alarm and error codes are reported via the VictronConnect app.
- A warning indicates a problem that, if not corrected, will result in a system shutdown, while an alarm indicates the reason for the system shutdown.

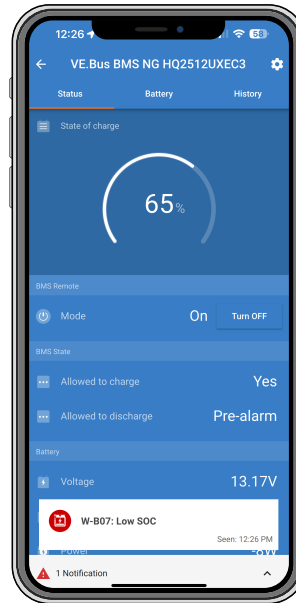

The following tables list all LED, warning, alarm and error codes:

Bluetooth Status LED	Description
Off	No system power or Bluetooth is disabled in the VictronConnect app.
Blue on	A Bluetooth device is connected.
Blue blinking	Bluetooth is active but no device is connected.

Error LED	Description
Off	No warning/alarm/error active.
Red blinking	A warning is active.
Red on	A alarm and/or error is active.

VE.Bus Status LED	Description
Off	When the Multi is off, either due to low cell voltage, remote off, or being manually switched off via the front panel switch, the BMS enters low-power mode. In this state, it continues to transmit BMS info frames, albeit at a slightly reduced frequency. To conserve energy, the BMS status LED does not illuminate in low-power mode.
Single blink every 10 seconds	The Multi is switched on, and BMS info frames are being sent.
LED will flash rapidly	The BMS is stuck in bootloader mode. This can occur, for example, after an interrupted firmware update. To resolve this, restart the update using VictronConnect.

Warning codes

VictronConnect warning code	Message	Instructions / Remarks
W-B01	Low cell voltage	Charge the battery or reduce the load to prevent an imminent system shutdown.
W-B05	Communication with battery lost	Check the cables between BMS and Battery.

VictronConnect warning code	Message	Instructions / Remarks
W-B07	Low SoC	Charge battery or reduce load to prevent imminent system shutdown.

Alarm codes

VictronConnect alarm code	Message	Instructions / Remarks
A-B01	Low cell voltage	Charge battery. The system will turn the loads back on when the battery is sufficiently charged.
A-B05	Communication with battery lost	Check the cables between BMS and Battery.
A-B07	Low SoC	Charge battery. The system will turn the loads back on when the battery is sufficiently charged.
A-B08	Low bank voltage	Charge battery. The system will turn the loads back on when the battery is sufficiently charged.
A-B09	High battery temperature	The battery temperature is too high for charging. Try to reduce the ambient temperature.

Error codes

VictronConnect error code	Message	Instructions / Remarks
E-B01	Battery configuration invalid	Check VictronConnect 'Battery' tab for more details. Check if batteries BMS cables are all connected
E-B05	Battery configuration invalid	Check VictronConnect 'Battery' tab for more details. Check if batteries BMS cables are all connected.
E-B09	Battery voltage not allowed	The battery voltage is too high or too low. Check the battery voltage and check the battery settings in the VictronConnect app. This error occurs when the battery voltage is outside all system voltage ranges (9V > Vbat > 60V)
E-B11	Hardware error	Contact your Victron dealer.

6. Frequently asked questions

Q1: I have disconnected the VE.Bus BMS NG, my inverter/charger will not switch on; why?

If the inverter/charger cannot find the BMS, it will go into an emergency mode. In this mode, the inverter/charger will charge the batteries with a maximum of 5A, up to 12, 24 or 48V (depending on the system voltage). While the inverter/charger is in this mode, only the "Mains on" LED is illuminated. If you disconnect the AC input, the inverter/charger will switch off and will not start to invert since it cannot get verification on the battery health from the BMS. Note that when the batteries are depleted or disconnected, a Quattro will need to be powered from AC input 1. Supplying power to AC input 2 will not make a Quattro switch on and start charging.

Q2: The batteries are empty, and the inverter/charger will not start to charge; how to get the system up and running again?

Connect a small battery charger, for example, a 5A charger, and wait for the battery voltage to get back up to 12, 24 or 48V (depending on the system voltage).

Q3: What happens with the inverter/charger when the BMS gives a low cell voltage signal?

The inverter/charger will be set to "charger only mode", and the batteries are charged when an AC input is available. Should AC not be available, the inverter/charger is off.

Q4: What happens with the inverter/charger when the BMS gives a high cell voltage signal?

The high cell voltage signal will only be given when there are unbalanced cells. The inverter/charger will switch to bulk and starts charging with a reduced charge current. This allows the balancing system in the batteries to re-balance the cells.

Q5: What does it mean when the BMS displays a VE.Bus Error 15?

With VE.Bus firmware versions below version xxxx415 the VE.Bus BMS NG will generate a VE.Bus Error 15, VE.Bus combination error. This error indicates that the VE.Bus products or firmware versions cannot be combined. Resolution: Update the inverter/charger to a firmware version xxxx415 or higher, if available.

7. Technical specifications VE.Bus BMS NG

Electrical	
Input voltage range	9 – 70 Vdc
Current draw - regular operation	10 mA (excluding Load disconnect current)
Current draw - low cell voltage	2 mA
Current draw - switched off via remote on/off terminal	1,50 mA
GX-pow output	1 A
Aux-in input	1 A
Pre-alarm output current rating	1 A, not short circuit protected
Load disconnect output	Normally high (output voltage \approx supply voltage – 1 V) Floating when the load needs to be disconnected Source current limit: 1 A Sink current: 0 A
Charge disconnect output	Normally high, (output voltage \approx supply voltage – 1 V) Floating when charger should be disconnected Source current limit: 10 mA Sink current: 0 A
Remote on/off terminals	Usage modes to turn the system on or off: a. ON when the L and H terminal are interconnected (switch or relay contact) b. ON when the L terminal is pulled to battery minus ($V < 3,5$ V) c. ON when the H terminal is high ($2,9$ V $< V_H < V_{bat}$) d. OFF in all other conditions
VE.Bus communications ports	2 x RJ45 sockets to connect to all VE.Bus products

General	
Operating temperature	-20 to +50 °C (0 - 120 °F)
Humidity	Max. 95 % (non-condensing)
Protection grade	IP20

Enclosure	
Material	ABS
Colour	Matt black with a blue sticker
Weight	120 gr
Dimension (h x w x d)	23,8 mm x 94,5 mm x 105,5 mm

Standards	
Safety	EN 60950
Emission	EN 61000-6-3, EN 55014-1
Immunity	EN 61000-6-2, EN 61000-6-1, EN 55014-2
Automotive	EN 50498

External AC-DC adapter (if installed)	
Min. power rating	1 A @ 12 V - If the nominal output voltage is > battery voltage, the AC-DC adapter takes over the power supply of the GX device.

8. Appendix

8.1. Appendix A

1. Loads which can be controlled directly by the Load disconnect output of the VE.Bus BMS NG:

- **Inverters:**

All Inverters VE.Direct and Inverters Smart. Connect the Load disconnect output of the BMS to terminal H of the 2-pole connector of the inverter.

- **DC-DC converters:**

All Tr-type DC-DC converters with remote on/off connector, the Orion 12/24-20 and the Orion XS. Connect the Load disconnect output of the BMS to the right-hand terminal of the 2-pole connector.

- **BatteryProtect and Smart BatteryProtect:**

Connect the Load disconnect output of the BMS to terminal 2.1 (right hand terminal) for the BatteryProtect and H pin of the 2-pole connector for the Smart BatteryProtect.

- **Cyrix-Li-Load:**

Connect the Load disconnect output of the BMS to the control input of the Cyrix.

2. Loads for which an [inverting remote on-off cable](#) is needed (article number ASS030550100 or -120):

- **VE.Bus inverters and VE.Bus Inverter Compact rated at 1200VA or more**

3. Solar charge controllers which can be controlled directly by the Charge disconnect output:

- **BlueSolar MPPT 150/70 and 150/80 CAN-bus:**

Connect the Charge disconnect output of the BMS to the left hand terminal of the 2-pole connector (B+).

- **SmartSolar MPPT 150/45 and higher, 250/60 and higher**

Connect the Charge disconnect output of the BMS to the **right-hand** terminal (marked +) or the **left-hand** terminal (marked H) of the 2-pole connector

4. Solar charge controllers for which a [VE.Direct non-inverting remote on-off cable](#) is needed (article number ASS030550320):

- **BlueSolar MPPT models except the BlueSolar MPPT 150/70 and 150/80 CAN-bus**

- **SmartSolar MPPT up to 150/35**

5. Battery Chargers:

- **Smart IP43 Chargers:**

Connect the Charge disconnect output of the BMS to terminal H of the 2-pole connector.

- **Skylla TG battery chargers:**

Use a [non-inverting remote on-off cable](#) (article number ASS030550200).

- **Skylla-i battery chargers:**

Use a [Skylla-i remote on-off cable](#) (article number ASS030550400).

- **Other battery chargers:**

Use a Cyrix-Li-Charge.

8.2. Displaying VE.Bus BMS NG SoC on a GX Device

Unlike the VE.Bus BMS V2, the VE.Bus BMS NG transmits State of Charge (SoC) over the VE.Bus network. This guide explains how to enable and display the SoC on a GX device.



Enabling this feature adds only the SoC. No other BMS parameters are forwarded to the GX device.

Enable “Battery Monitor” on the MultiPlus/Quattro

To forward SoC to the GX device, you must enable the Battery Monitor setting on the MultiPlus/Quattro. This can be done via Remote VEConfigure or VictronConnect.

Using Remote VEConfigure

1. Download the Remote VEConfigure file from the device
2. Open the file in VEConfigure
3. In the General tab, tick Battery monitor



"Battery capacity" and "Charge efficiency" are not relevant in this case, as these parameters are managed by the VE.Bus BMS NG.

4. Click File → Exit and confirm saving the changes
5. Click on 'Yes'
6. Upload the updated file back to the MultiPlus/Quattro using Remote VEConfigure

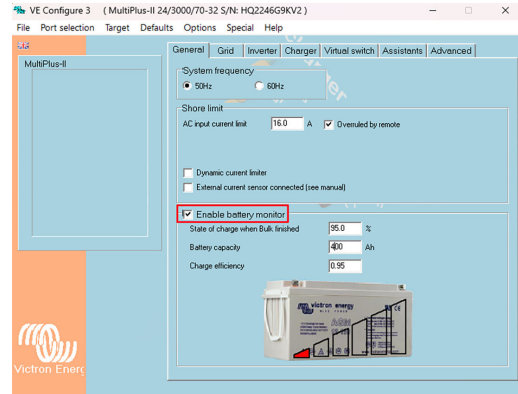

Using VictronConnect

1. Connect a MK3-USB interface between the MultiPlus/Quattro and the device running VictronConnect (PC or Android). Refer to the [MK3-USB interface documentation](#).
2. Open VictronConnect
3. Select the MultiPlus/Quattro from My devices
4. Navigate to Settings → General
5. Enable the Battery monitor option

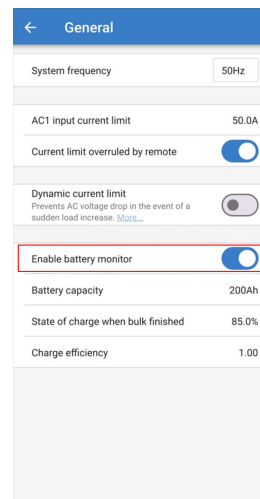

Selecting the battery monitor in the GX device

This step is only required if multiple battery monitoring devices are connected to the GX device.

In such cases, ensure that the MultiPlus/Quattro is selected as the active battery monitor:

- Navigate to Settings → System Setup → Battery monitor and enable the option on the MultiPlus/Quattro

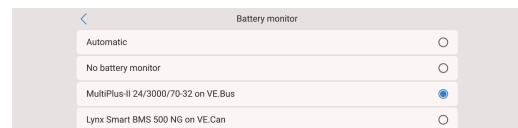

8.3. Powering the VE.Bus BMS NG without a connected Multi

In situations where the VE.Bus BMS NG must be operational without a connected Multi, it can be powered independently.

Step-by-step

1. Connect a DC power supply between:
 - Pin 3 (GND) of either RJ45 socket on the VE.Bus BMS NG — the sockets are internally connected, so using one is sufficient — and

- +Bat terminal on the Phoenix 6-pin connector.
2. Ensure correct polarity and supply voltage according to [Technical specifications VE.Bus BMS NG \[28\]](#).
 3. When powered, the VE.Bus BMS NG initialises and battery data becomes available via VictronConnect.

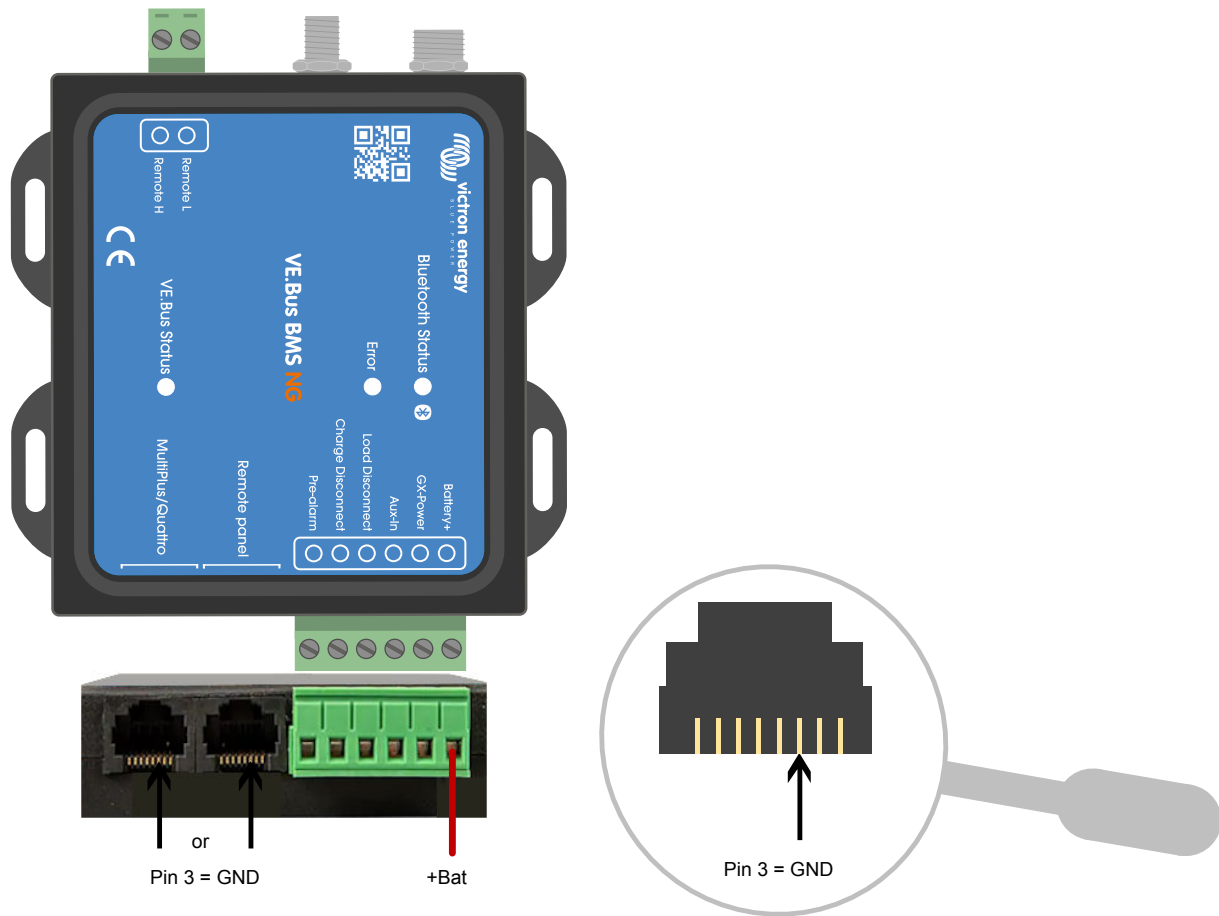

8.4. Enclosure dimensions VE.Bus BMS NG

