

GARMIN®

FORCE® KRAKEN TROLLING MOTOR

Field Service Manual

© 2024 Garmin Ltd. or its subsidiaries

All rights reserved. Under the copyright laws, this manual may not be copied, in whole or in part, without the written consent of Garmin. Garmin reserves the right to change or improve its products and to make changes in the content of this manual without obligation to notify any person or organization of such changes or improvements. Go to www.garmin.com for current updates and supplemental information concerning the use of this product.

Garmin®, the Garmin logo, ActiveCaptain®, and Force® are trademarks of Garmin Ltd. or its subsidiaries, registered in the USA and other countries. These trademarks may not be used without the express permission of Garmin.

DuPont™ and Teflon® are trademarks of E. I. du Pont de Nemours and Company or its affiliates.

MN: A04109 / B04109 / C04109

拖釣推進器

Table of Contents

Tools, Supplies, and Equipment Needed	1
Overview and Part Locations	2
Maintenance Needs and Schedule	4
Service Parts	13
Service Procedures	18
Disassembly Procedures	27
Assembly Procedures	51

Tools, Supplies, and Equipment Needed

WARNING

See the *Important Safety and Product Information* guide in the product box for product warnings and other important information.

Failure to follow these warnings, cautions, and notices could result in personal injury, damage to the vessel or device, or poor product performance.

You must perform the services and repairs described in this document according to the instructions provided. Failure to do so could result in damage to the trolling motor or its components or could result in serious personal injury.

Repairing and performing maintenance on Garmin® electronics is complex work that can result in serious personal injury or product damage if not done correctly.

Always disconnect the motor from the battery before handling or working with the propeller, propeller drive motor, electrical connections, or electronics enclosures to avoid serious injury or property damage.

CAUTION

When stowing or deploying the motor, be aware of the risk of entrapment or pinching from moving parts, which can result in injury.

When stowing or deploying the motor, be aware of slick surfaces around the motor. Slipping when stowing or deploying the motor may result in injury.

NOTICE

Garmin is not responsible for, and does not warrant, the work that you or a non-authorized repair provider perform on your product.

The tools, supplies, and equipment needed to service and repair the trolling motor depend on the service or repair needed. Not all of the items listed are applicable for every procedure.

Tools, Supplies, and Equipment Needed for Maintenance

When performing routine maintenance, you may need the following tools and supplies.

- #2 Phillips bit or screwdriver
- 5 mm, 4 mm, 3 mm, and 2.5 mm hex bits or wrenches
- $\frac{9}{16}$ in. socket for removing the propeller (a 15 mm socket can be used, if necessary)
- Replacement anodes (010-12832-35)
- Wire brush
- Synthetic or marine grade, general-purpose grease
- Non-stick, dry-film lubricant (such as DuPont™ Dry Film Lubricant with Teflon®)
- Dielectric grease
- Isopropyl alcohol (for cleaning areas before applying touch-up paint)
- Liquid polyurethane paint (for touching up nicks and scratches)

Tools, Supplies, and Equipment Needed for Repair

When performing repair or replacement procedures, you must have the following tools and supplies.

- Suitable workbench or table
 - Must be at least 10 ft. long for working on the 63 in. models
 - Must be at least 11 ft. long for working on the 75 in. models
 - Must be at least 15 ft. long for working on the 90 in. models
- #1, #2, and #3 Phillips screwdrivers
- 2.5 mm, 3 mm, 4 mm, and 5 mm hex bits or wrenches
- $\frac{9}{16}$ in. socket for removing the propeller. A 15 mm socket is acceptable, if necessary.
- Torque wrench
 - With 4 mm, 6 mm, and 5 mm hex bits
 - Capable of measuring torque from 4 N-m (3 lbf-ft) to 8.1 N-m (6 lbf-ft.)
- Needle-nose pliers
- Synthetic or marine grade general-purpose grease (for replacing the latching mechanism or steering servo components)
- Dielectric grease (for replacing the power cable or coil cable)

Overview and Part Locations

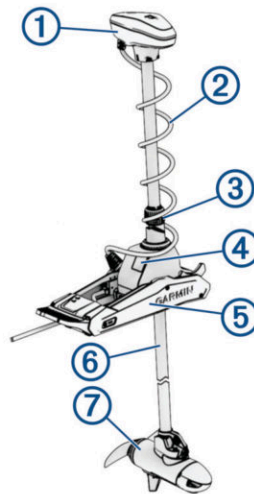

Item	Description
①	Shaft cap
②	Wiring harness and junction box (and GT56 transducer cable, if present)
③	Depth-adjustment assembly
④	Steering servo
⑤	Mount
⑥	Shaft
⑦	Drive motor and propeller

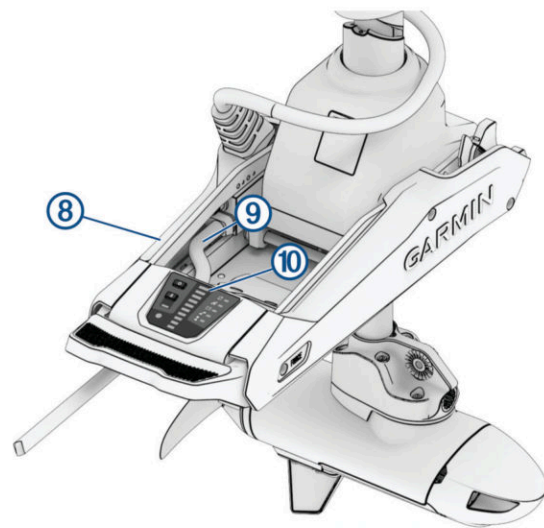

Item	Description
⑧	Mount base
⑨	Power cable
⑩	Display panel

Maintenance Needs and Schedule

⚠ CAUTION

Use extreme care when following the procedures in this section. Some maintenance tasks require you to move the motor from the stowed to the deployed position multiple times, which presents a potential for hands or fingers to be crushed by the weight of the motor.

NOTICE

After using the motor in salt water or brackish water, you must rinse off the entire motor with fresh water, and apply a water-based silicone spray using a soft cloth. You should avoid spraying jets of water at the cap on the top of the shaft when rinsing the motor.

To maintain your warranty, you must perform a series of routine maintenance tasks as you prepare your motor for the season. If you use or transport the motor in salt water or dry, dusty environments (traveling on gravel roads, for example) you should perform these tasks more often during the season.

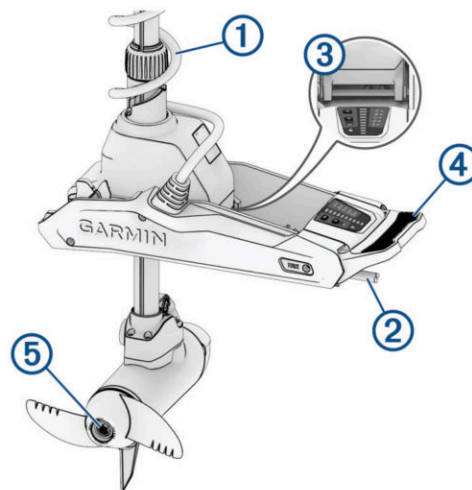

- Examine the coil cable ① for wear, and replace it as necessary.
- Check and clean the power cables ②.
- Lubricate the hinge ③ with marine grade grease (*Lubricating the Hinge*, page 5).
- Clean and lubricate the stow and deploy latch pedal ④ (*Cleaning and Lubricating the Locking Mechanism*, page 6) and latch bar.
- Clean or replace the anodes ⑤ in the propeller drive motor (*Servicing the Anodes*, page 7).
- Remove entangled fishing line and other obstructions from the propeller.

Lubricating the Hinge

The hinge allows the motor to transition smoothly from the stowed to deployed position and back again. You should lubricate the hinge as needed.

- 1 Ensure the motor is in the deployed position.
- 2 Locate the two hinge points ①.

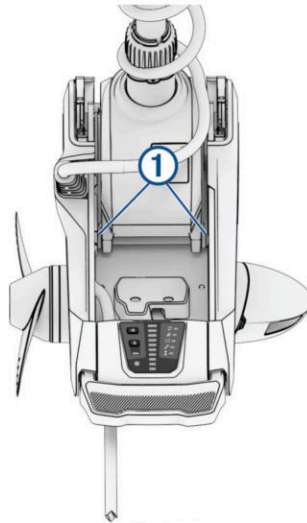

- 3 Apply a non-stick, dry-film lubricant to each hinge point, in the space between the moving parts ②, and allow it to dry according to the instructions provided with the product.

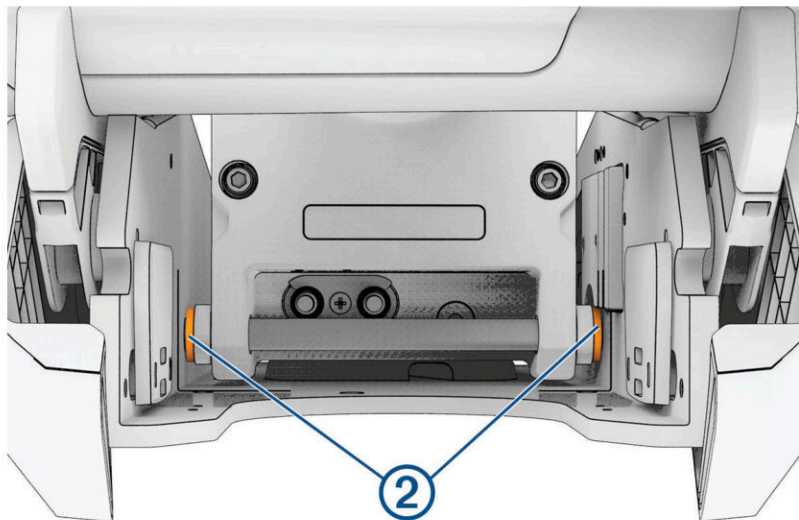

- 4 Move the motor from the stowed to the deployed position and back a number of times to distribute the lubricant.
- 5 If necessary, apply additional lubricant and repeat the previous step.

Cleaning and Lubricating the Locking Mechanism

NOTE: This procedure is best performed with the motor in the stowed position.

- 1 Place the motor in the stowed position so you can access the locking mechanisms ①.

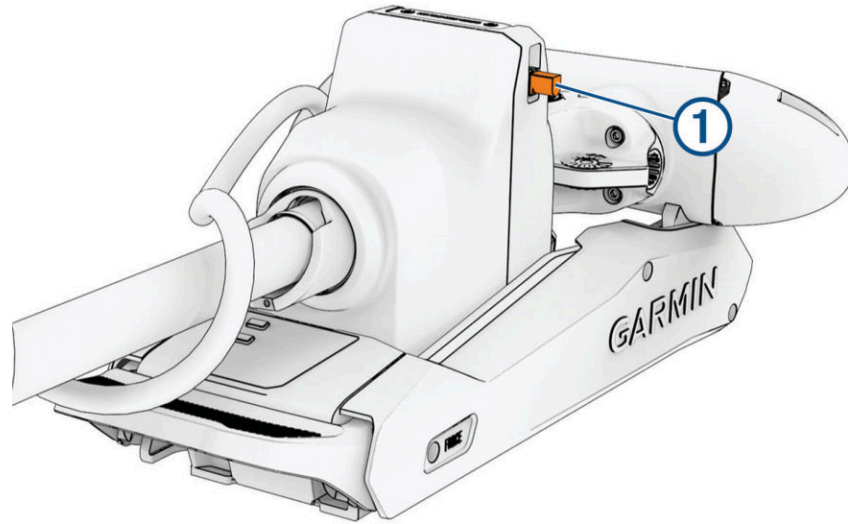

- 2 Clean any debris, dirt, and build up from all of the locking mechanism channels.
- 3 Apply a synthetic or marine grade, general-purpose grease to the locking mechanism and the channels.
- 4 Manually move the latch a number of times to move the mechanism in the channels and distribute the grease.
- 5 If necessary, apply additional grease and repeat the previous step.
- 6 Clean any debris, dirt, and build up from the latch receiver ②.

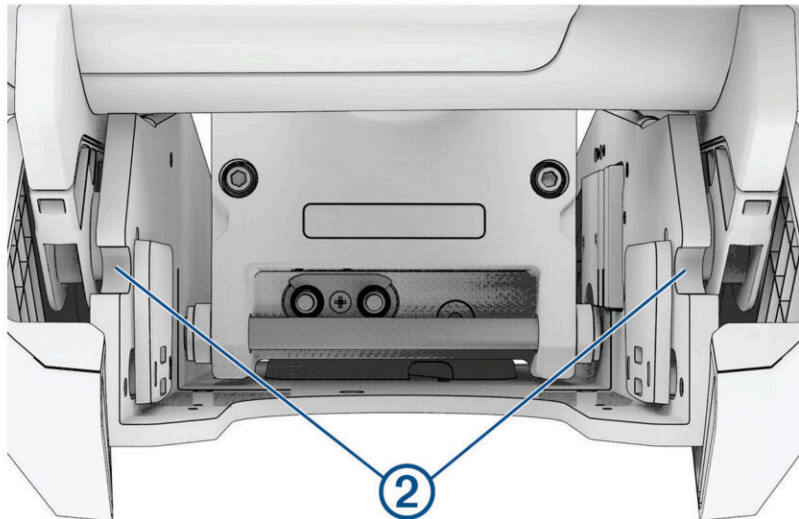

- 7 Apply a synthetic or marine grade, general-purpose grease to the latch receiver and both ramped surfaces and slots on the mount base so the locking mechanism slides smoothly into the receiver.

Servicing the Anodes

The anodes protect the motor components from corrosion, and each season they must be examined and cleaned or replaced if necessary.

- 1 Using a $\frac{9}{16}$ in (15 mm) socket, loosen the nut on the end of the propeller.
- 2 Remove the nut, lock washer, flat washer, and anode ①.

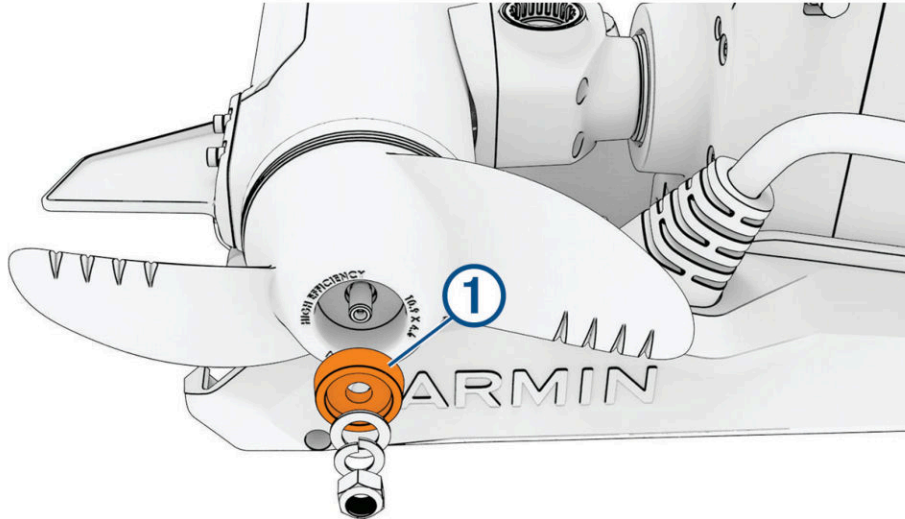

- 3 Examine the anode, and complete an action:
 - If the anode is more than half of the original size, clean the anode using a wire brush or sandpaper.

NOTICE

Remove the anode from the motor before cleaning it with a wire brush or sandpaper. Cleaning the anode while installed on the motor could damage the motor, accelerate corrosion, and shorten the life of the motor.

- If the anode is less than half of the original size, discard the anode and purchase a replacement.
- 4 Place the cleaned or new anode on the propeller shaft, and secure the propeller with the flat washer, lock washer, and nut.
 - 5 Using a $\frac{9}{16}$ in (15 mm) socket, tighten the nut to 8.13 N-m (6 lbf-ft).
 - 6 Using a 4 mm hex bit or wrench, remove the four screws ② securing the skeg on the bottom of the motor.

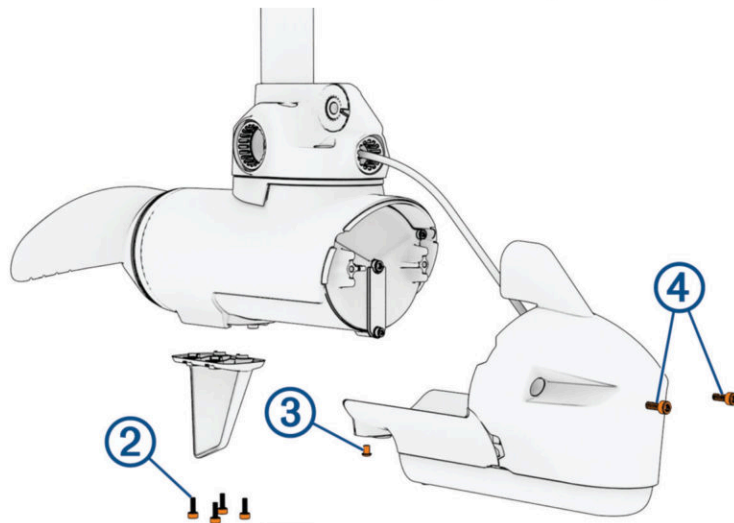

- 7 Using a 3 mm hex bit or wrench, remove the screw ③ that secures the transducer and nose cone to the bottom of the motor .
- 8 Using a 4 mm hex bit or wrench, remove the screws ④ to disconnect the nose cone from the front of the motor.

9 Using a 3 mm hex bit or wrench, remove the screw and anode ⑤ on the front of the motor.

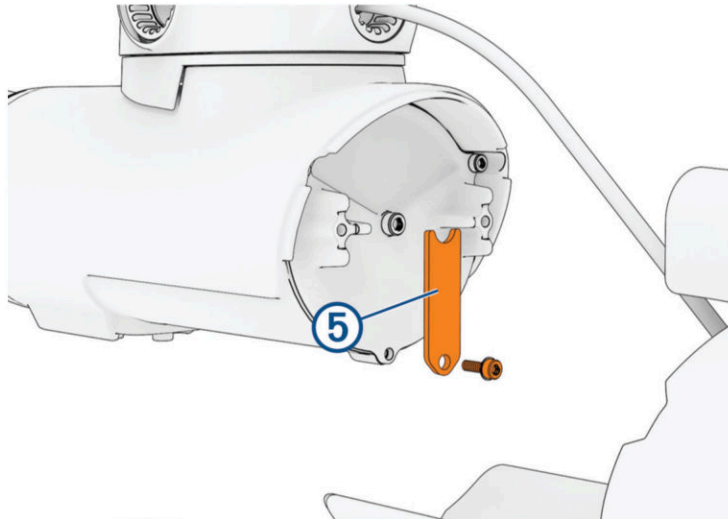

10 Examine the anode, and complete an action:

- If the anode is more than half of the original size, clean the anode using a wire brush or sandpaper.
- If the anode is less than half of the original size, discard the anode and purchase a replacement.

11 Place the cleaned or new anode on the screw and secure it to the motor.

12 Secure the nose cone to the front of the motor.

13 Install the screw that secures the transducer and nose cone to the bottom of the motor.

14 Install the skag on the bottom of the motor.

Checking the Motor Cradle and Latch Pedal Springs

The springs allow you to smoothly stow and deploy the motor. The motor cradle and latch pedal springs may become worn over time. If the springs are damaged, rusted, or worn, you must replace them. Before you replace the latch pedal springs, you must remove the mount base shrouds ([Removing the Mount Shrouds, page 27](#)).

WARNING

Failure to replace worn or damaged springs could result in impact damage to the trolling motor or accidental trolling motor deployment, resulting in property damage or personal injury.

- 1 With the motor in the stowed position, examine the two latch pedal springs **①** and two cradle springs **②** for wear, corrosion, and damage.

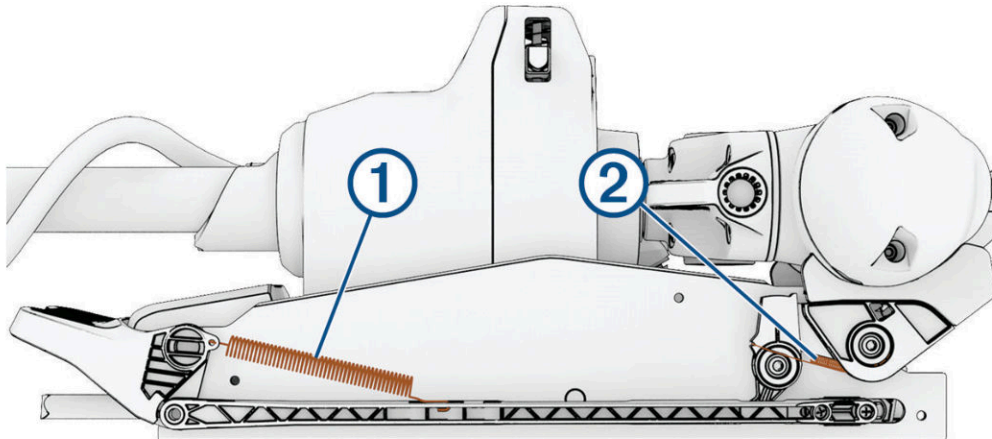

- 2 Select an action:
 - If the springs are in good condition, no further action is needed.
 - If the springs are damaged, weak, or corroded, replace them ([Replacing the Latch and Cradle Tension Springs, page 19](#)).

Checking the Cradle Catches

The cradle catches protect the propeller drive motor and the mount from impact when stowing the motor and may become worn over time. If the cradle-catch components are damaged or worn, you must replace them.

WARNING

Failure to replace worn or damaged pads and cradle catches could result in impact damage to the trolling motor or accidental trolling motor deployment, resulting in property damage or personal injury.

- 1 With the motor in the deployed position, examine the pads and cradle catches  for wear, cracks, and damage.

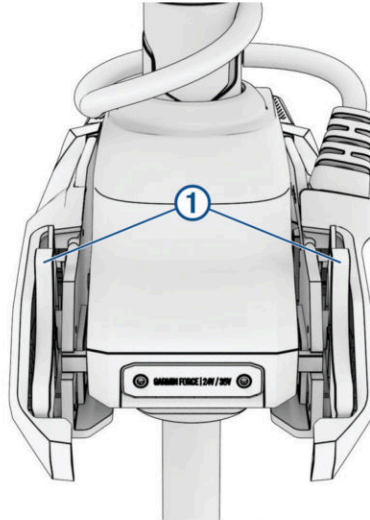

- 2 Select an action:
 - If the cradle-catch components are in good condition, and the cradle pad is not worn through, no further action is needed.
 - If the cradle-catch components are damaged, the cradle does not lock, or if the cradle pad is worn through, replace them ([Replacing the Cradle Hardware, page 19](#)).

Checking the Latch Pusher Linkage

The latch pusher assembly allows you to stow, deploy, and lock the motor securely. The latch pusher linkage may become worn over time. If the linkage is damaged or worn, you must replace it. Before you check the latch pusher linkage, you must remove the mount shrouds ([Removing the Mount Shrouds, page 27](#)).

WARNING

Failure to replace worn or damaged latch pusher linkage components could result in impact damage to the trolling motor or accidental trolling motor deployment, resulting in property damage or personal injury.

- 1 Inspect the latch pusher linkages and connected latch pushers.

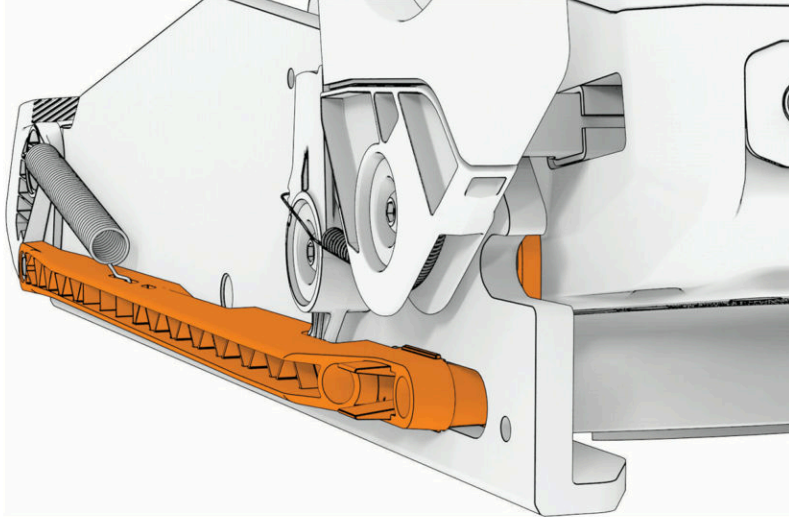

- 2 Select an action:

- If the latch pusher linkages and connected latch pushers are in good condition, no further action is needed.
- If the latch pusher linkages or connected latch pushers are damaged, weak, or broken, replace them ([Replacing the Latch Pusher Hardware, page 19](#)).

Checking the Latch Pedal

Before you check the latch pedal and springs, you must remove the mount shrouds ([Removing the Mount Shrouds, page 27](#)).

The latch pedal allows you to stow, deploy, and lock the motor securely. The assembly may become worn over time. If the components are damaged or worn, you must replace them.

WARNING

Failure to replace worn or damaged latch pedal components could result in impact damage to the trolling motor or accidental trolling motor deployment, resulting in property damage or personal injury.

Failure to fully stow the motor when not in use could result in accidental trolling motor deployment, resulting in potential property damage or personal injury.

- 1 Examine the latch pedal and springs for wear and damage.

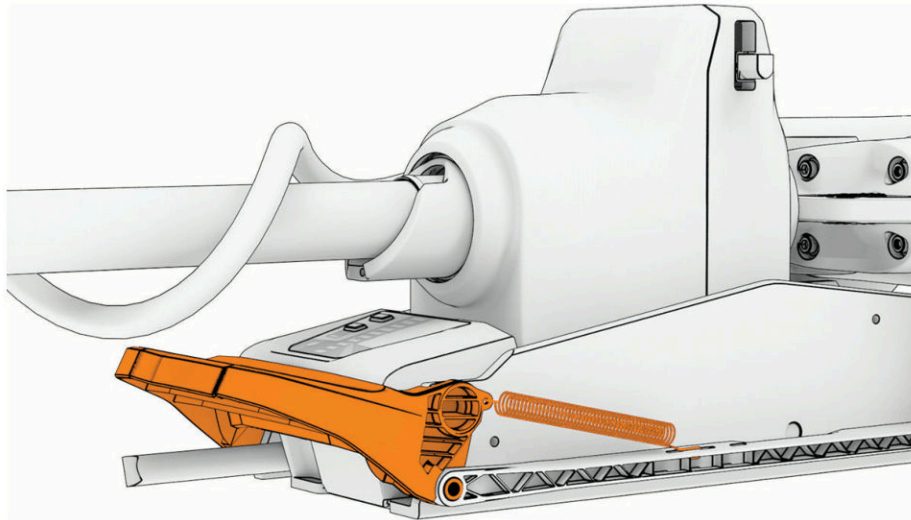

- 2 While supporting the shaft and motor, test the latch pedal function.
- 3 Select an action:
 - If the components are in good condition, no further action is needed.
 - If the components are damaged or the latch does not operate correctly or lock, replace them ([Replacing the Latch Pedal, page 19](#)).

Checking the Servo Landing Pad

The servo landing pad is part of the mount base that protects the motor shaft and the mount base when the motor is stowed.

WARNING

Failure to replace a worn or damaged servo landing pad could result in impact damage to the trolling motor or accidental trolling motor deployment, resulting in property damage or personal injury.

- 1 Place the motor in the deployed position, and check the servo landing pad  for damage.

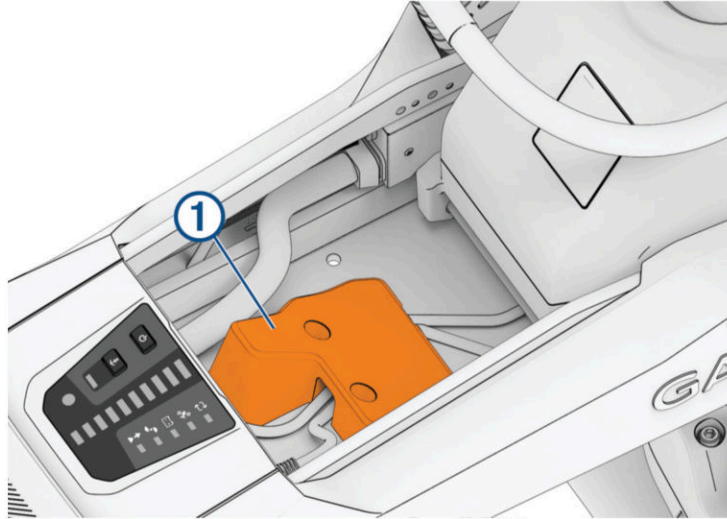

- 2 Select an action:
 - If the servo landing pad is undamaged, no further action is needed.
 - If the servo landing pad is damaged, replace it (*Replacing the Servo Landing Pad*, page 22).

Fixing Paint Scratches

Over time, parts of the motor may become scratched or dinged. You can use paint to touch up these areas for cosmetic purposes.

- 1 Using isopropyl alcohol, thoroughly clean the areas where the paint has been scratched or damaged.
- 2 Apply liquid polyurethane touch-up paint to the scratched or damaged areas.
- 3 Follow the instructions on the paint, and allow for proper drying before using the motor.

Service Parts

You can use these diagrams to identify and order service parts. You can follow the links where provided for detailed disassembly and replacement procedures.

To order the service parts listed in this manual, contact Garmin at 1-800-800-1420 or send an email to dealer.tech@garmin.com to place an order.

Shaft and Cable Parts

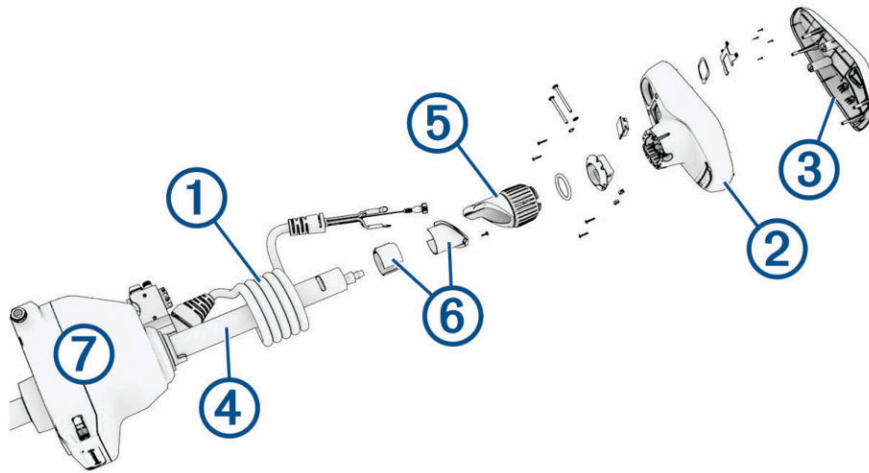

Item	Description	Service Part Number	Replacement Procedure
①	Coil cable and junction box	63" black: S00-01100-18 63" white: S00-01100-19 75" black: S00-01100-20 75" white: S00-01100-21 90" white: S00-01100-22	Replacing the Coil Cable and Junction Box, page 23
②	Shaft cap bottom housing	Black: S00-01100-29 White: S00-01100-30	Replacing the Bottom Shaft Cap Assembly, page 23
③	Shaft cap upper housing Shaft cap upper housing with antenna box	Black: S11-05642-10 White: S11-05642-11 Black with antenna box: S11-05642-00 White with antenna box: S11-05642-01	Replacing the Upper Shaft Cap Housing, page 24
④	Shaft	63" black: S00-01100-32 63" white: S00-01100-33 75" black: S00-01100-34 75" white: S00-01100-35 90" white: S00-01100-36	Replacing the Shaft and Motor Assembly, page 18
⑤	Depth adjustment assembly	S00-01100-15	Replacing the Depth Adjustment Assembly, page 21
⑥	Shaft mini-tumbler and biasing bushing	S00-01100-16	Replacing the Shaft Mini-Tumbler and Biasing Bushing, page 22
⑦	Steering servo	Black: S00-01100-10 White: S00-01100-11	Replacing the Full Servo Assembly, page 20

Propeller Drive Motor Parts

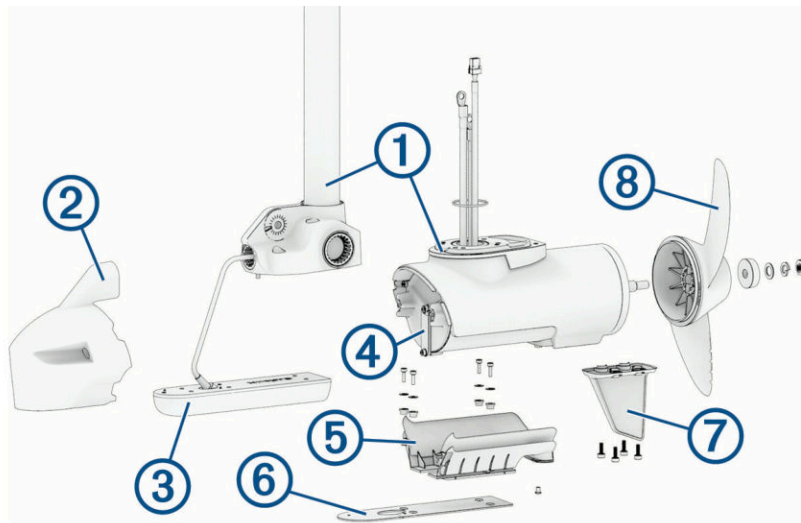

Item	Description	Service Part Number	Replacement Procedure
①	Shaft and propeller drive motor	63" black: S11-05722-6B 63" white: S11-05722-6W 75" black: S11-05722-7B 75" white: S11-05722-7W 90" white: S11-05722-8W	Replacing the Shaft and Motor Assembly, page 18
②	Nose cone	Black for motors with transducer: 010-12832-20 White for motors without transducer: 010-12832-23	Instructions included with kit
③	Transducer	Contact Garmin support for replacement transducer options.	Instructions included with kit
④	Motor anode	010-12832-35	Servicing the Anodes, page 7
⑤	Lower nose cone	Black for motors with transducer: 010-12832-20 White for motors without transducer: 010-12832-23	Instructions included with kit
⑥	Transducer pad	010-12832-25	Instructions included with kit
⑦	Skeg	Black 010-12832-18 White 010-12832-19	Instructions included with kit
⑧	Propeller	Power propeller: 010-12832-00 Weedless propeller: 010-12832-01	Instructions included with kit

Mount Parts

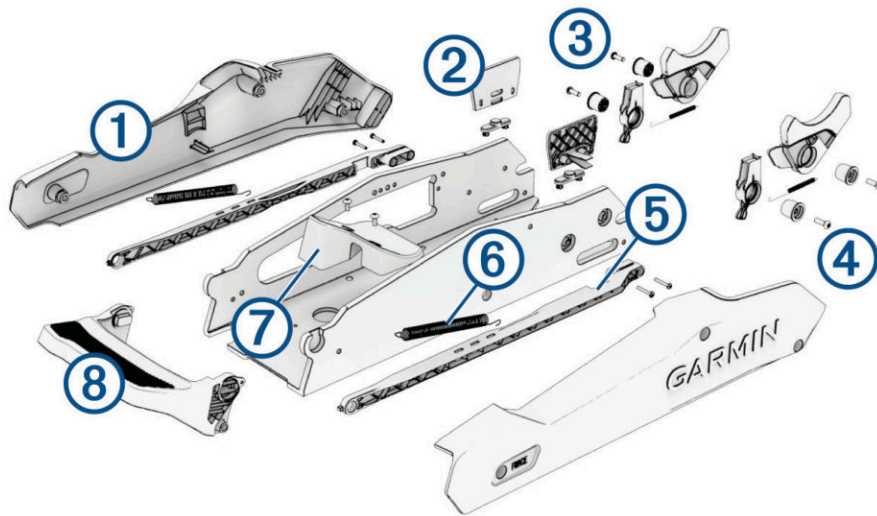

Item	Description	Service Part Number	Replacement Procedure
①	Mount shrouds	Black: S00-01100-08 White: S00-01100-09	Replacing the Mount Shrouds, page 20
②	Latch pusher	S00-01100-02	Replacing the Latch Pusher Hardware, page 19
③	Cradle hardware	S00-01100-01	Replacing the Cradle Hardware, page 19
④	Cradle replacement bushings	S00-01100-24	Replacing the Cradle Hardware, page 19
⑤	Latch pusher linkage	S00-01100-02	Replacing the Latch Pusher Hardware, page 19
⑥	Latch pedal tension spring	S00-01100-05	Replacing the Latch and Cradle Tension Springs, page 19
⑦	Servo landing pad	S00-01100-17	Replacing the Servo Landing Pad, page 22
⑧	Latch pedal	Black: S00-01100-03 White S00-01100-04	Replacing the Latch Pedal, page 19

Steering and Electronics Parts

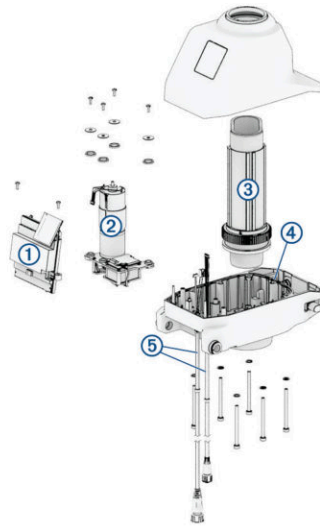

Item	Description	Service Part Number	Service Procedure
①	Steering servo PCB	S00-01100-27	<i>Replacing the Steering Servo PCB, page 25</i>
②	Steering motor module	S00-01100-26	<i>Replacing the Steering Motor Module, page 25</i>
③	Steering shaft carrier	S11-05673-30	<i>Replacing the Shaft Carrier, page 25</i>
④	Servo gasket	S00-01100-28	<i>Replacing the Steering Servo Gasket, page 26</i>
⑤	Steering servo cables	S00-01100-25	<i>Replacing the Steering Servo Cables, page 24</i>

Service Procedures

Replacing the Full Drive Assembly

- 1 Disconnect the power cable and transducer cable (if present).
- 2 Remove the mount shrouds (*Removing the Mount Shrouds*, page 27).
- 3 Disconnect the junction box (*Removing the Coil Cable Junction Box from the Mount Base*, page 44).
- 4 Deploy the motor.
- 5 Disconnect the steering servo cables (*Disconnecting the Steering Servo Cables*, page 32).
- 6 Remove the servo landing pad (*Removing the Servo Landing Pad*, page 32).
- 7 Remove the pivot pin (*Removing the Pivot Pin*, page 45).
- 8 While supporting the steering servo, remove the old full drive assembly.
- 9 Install servo bushings in the new drive system assembly (*Installing the Bushings in the Steering Servo Housing*, page 52).
- 10 Install the new full drive assembly.
- 11 Connect the new junction box (*Connecting the Coil Cable Junction Box to the Mount Base*, page 61).
- 12 Route the new power and transducer cables (*Routing the Power and Transducer Cables Through the Mount*, page 55).
- 13 Install the pivot pin (*Reinstalling the Pivot Pin*, page 53).
- 14 Reconnect the steering servo cables (*Connecting the Steering Servo Cables*, page 56).
- 15 Reinstall the servo landing pad (*Installing the Servo Landing Pad*, page 56).
- 16 Install the mount shrouds (*Installing the Mount Shrouds*, page 68).
- 17 Reconnect the power cable and transducer cable (if present).

Replacing the Shaft and Motor Assembly

- 1 Open the shaft cap (*Opening the Shaft Cap*, page 33).
- 2 Disconnect the shaft cap cables (*Disconnecting the Cables in the Shaft Cap*, page 35).
- 3 Remove the shaft cap (*Removing the Shaft Cap*, page 36).
- 4 Remove the skeg (*Removing the Skeg*, page 46).
- 5 Remove the propeller (*Removing the Propeller*, page 46).
- 6 Remove the depth-adjustment assembly (*Removing the Depth-Adjustment Assembly*, page 37).
- 7 Remove the old shaft and motor assembly (*Removing the Shaft from the Steering Servo Housing*, page 40).
- 8 Remove the mini-tumbler and biasing bushing (*Removing the Shaft Mini-Tumbler and Biasing Bushing*, page 39).
- 9 Install the new shaft and motor assembly (*Installing the Shaft in the Steering Servo Housing*, page 60).
- 10 Install the mini-tumbler and biasing bushing (*Installing the Shaft Mini-Tumbler and Biasing Bushing*, page 57).
- 11 Install the depth-adjustment collar (*Reinstalling the Depth-Adjustment Assembly*, page 57).
- 12 Install the propeller (*Installing the Propeller*, page 70).
- 13 Install the skeg (*Installing the Skeg*, page 69).
- 14 Install the shaft cap (*Installing the Shaft Cap*, page 62).
- 15 Connect the shaft cap cables (*Connecting the Cables in the Shaft Cap*, page 63).
- 16 Close the shaft cap (*Closing the Shaft Cap*, page 65).

Replacing the Cradle Hardware

- 1 Deploy the motor.
- 2 Remove the mount shrouds (*Removing the Mount Shrouds*, page 27).
- 3 Remove the old cradle hardware (*Removing the Cradle Hardware*, page 28).
- 4 Install the new cradle hardware (*Installing the Cradle Hardware*, page 66).
- 5 Install the mount shrouds (*Installing the Mount Shrouds*, page 68).

Replacing the Latch Pusher Hardware

- 1 Remove the mount shrouds (*Removing the Mount Shrouds*, page 27).
- 2 Remove the old tension springs (*Removing the Latch Tension Springs*, page 29).
- 3 Remove the old latch pushers (*Removing the Latch Pushers*, page 28).
- 4 Remove the old latch pusher linkages (*Removing the Latch Pusher Linkage*, page 29).
- 5 Install the new latch pusher linkages (*Installing the Latch Pusher Linkage on the Latch Pedal*, page 65).
- 6 Install the new latch pushers (*Installing the Latch Pushers*, page 67).
- 7 Install the new tension springs (*Installing the Latch Tension Springs*, page 67).
- 8 Install the mount shrouds (*Installing the Mount Shrouds*, page 68).

Replacing the Latch Pedal

- 1 Remove the mount shrouds (*Removing the Mount Shrouds*, page 27).
- 2 Remove the tension springs (*Removing the Latch Tension Springs*, page 29).
- 3 Remove the latch pusher linkages (*Removing the Latch Pusher Linkage*, page 29).
- 4 Remove the old latch pedal (*Removing the Latch Pedal*, page 30).
- 5 Install the new latch pedal (*Installing the Latch Pedal*, page 69).
- 6 Reinstall the latch pusher linkages (*Installing the Latch Pusher Linkage on the Latch Pedal*, page 65).
- 7 Reinstall the tension springs (*Installing the Latch Tension Springs*, page 67).
- 8 Reinstall the mount shrouds (*Installing the Mount Shrouds*, page 68).

Replacing the Latch and Cradle Tension Springs

- 1 Deploy the motor.
- 2 Remove the mount shrouds (*Removing the Mount Shrouds*, page 27).
- 3 Remove the old cradle tension springs (*Removing the Cradle Tension Springs*, page 27).
- 4 Remove the old latch tension springs (*Removing the Latch Tension Springs*, page 29).
- 5 Install the new latch tension springs (*Installing the Latch Tension Springs*, page 67).
- 6 Install the new cradle tension springs (*Installing the Cradle Tension Springs*, page 68).
- 7 Reinstall the mount shrouds (*Installing the Mount Shrouds*, page 68).

Replacing the Full Shaft Cap

- 1 Disconnect the power cable.
- 2 Open the shaft cap (*Opening the Shaft Cap*, page 33).
- 3 Disconnect the shaft cap cables (*Disconnecting the Cables in the Shaft Cap*, page 35).
- 4 Remove the coil cable from the shaft cap (*Removing the Coil Cable from the Shaft Cap*, page 35).
- 5 Remove the old shaft cap (*Removing the Shaft Cap*, page 36).
- 6 Install the new shaft cap (*Installing the Shaft Cap*, page 62).
- 7 Install the coil cable in the new shaft cap (*Installing the Coil Cable in the Shaft Cap*, page 62).
- 8 Connect the shaft cap cables (*Connecting the Cables in the Shaft Cap*, page 63).
- 9 Close the shaft cap (*Closing the Shaft Cap*, page 65).
- 10 Reconnect the power cable.

Replacing the Mount Shrouds

- 1 Remove the old mount shrouds (*Removing the Mount Shrouds*, page 27).
- 2 Install the new mount shrouds (*Installing the Mount Shrouds*, page 68).

Replacing the Full Servo Assembly

- 1 Remove the mount shrouds (*Removing the Mount Shrouds*, page 27).
- 2 Open the shaft cap (*Opening the Shaft Cap*, page 33).
- 3 Disconnect the cables in the shaft cap (*Disconnecting the Cables in the Shaft Cap*, page 35).
- 4 Remove the shaft cap (*Removing the Shaft Cap*, page 36).
- 5 Remove the depth-adjustment assembly (*Removing the Depth-Adjustment Assembly*, page 37).
- 6 Remove the shaft from the steering servo housing (*Removing the Shaft from the Steering Servo Housing*, page 40).
- 7 Remove the shaft mini-tumbler and biasing bushing (*Removing the Shaft Mini-Tumbler and Biasing Bushing*, page 39).
- 8 Remove the servo landing pad (*Removing the Servo Landing Pad*, page 32).
- 9 Disconnect the steering servo cables (*Disconnecting the Steering Servo Cables*, page 32).
- 10 Remove the pivot pin (*Removing the Pivot Pin*, page 45).
- 11 Remove the old servo assembly.
- 12 Install the new bushings in the new servo assembly (*Installing the Bushings in the Steering Servo Housing*, page 52).
- 13 Set the new servo housing in place.
- 14 Reinstall the pivot pin (*Reinstalling the Pivot Pin*, page 53).
- 15 Connect the steering servo cables (*Connecting the Steering Servo Cables*, page 56).
- 16 Install the servo landing pad (*Installing the Servo Landing Pad*, page 56).
- 17 Install the shaft in the steering servo housing (*Installing the Shaft in the Steering Servo Housing*, page 60).
- 18 Install the shaft mini-tumbler and biasing bushing (*Installing the Shaft Mini-Tumbler and Biasing Bushing*, page 57).
- 19 Install the depth-adjustment collar (*Reinstalling the Depth-Adjustment Assembly*, page 57).
- 20 Install the shaft cap (*Installing the Shaft Cap*, page 62).
- 21 Connect the cables in the shaft cap (*Connecting the Cables in the Shaft Cap*, page 63).
- 22 Close the shaft cap (*Closing the Shaft Cap*, page 65).
- 23 Install the mount shrouds (*Installing the Mount Shrouds*, page 68).

Replacing the Release Latch

- 1 Remove the old release latch (*Removing the Release Latch*, page 31).
- 2 Install the new release latch kit (*Installing the Release Latch*, page 51).

Replacing the Pivot Pin

- 1 Deploy the motor.
- 2 Remove the mount shrouds (*Removing the Mount Shrouds*, page 27).
- 3 Remove the pivot pin (*Removing the Pivot Pin*, page 45).
- 4 Install the new pivot pin (*Reinstalling the Pivot Pin*, page 53).
- 5 Install the mount shrouds (*Installing the Mount Shrouds*, page 68).

Replacing the Depth Adjustment Assembly

- 1 Disconnect the power cable and transducer cable (if present).
- 2 Remove the mount shrouds (*Removing the Mount Shrouds*, page 27).
- 3 Open the shaft cap (*Opening the Shaft Cap*, page 33).
- 4 Disconnect the shaft cap cables (*Disconnecting the Cables in the Shaft Cap*, page 35).
- 5 Remove the shaft cap (*Removing the Shaft Cap*, page 36).
- 6 Remove the depth-adjustment assembly (*Removing the Depth-Adjustment Assembly*, page 37).
- 7 Install the new depth-adjustment collar (*Reinstalling the Depth-Adjustment Assembly*, page 57).
- 8 Install the shaft cap (*Installing the Shaft Cap*, page 62).
- 9 Connect the shaft cap cables (*Connecting the Cables in the Shaft Cap*, page 63).
- 10 Close the shaft cap (*Closing the Shaft Cap*, page 65).
- 11 Reconnect the power cable and transducer cable (if present).

Replacing the Shaft Cap and Antenna Box

Before you replace the shaft cap and antenna box, you must open the shaft cap ([Opening the Shaft Cap, page 33](#)).

- 1 Unscrew and disconnect the GPS data connector ①.
Ensure the o-ring remains in place inside the connector.

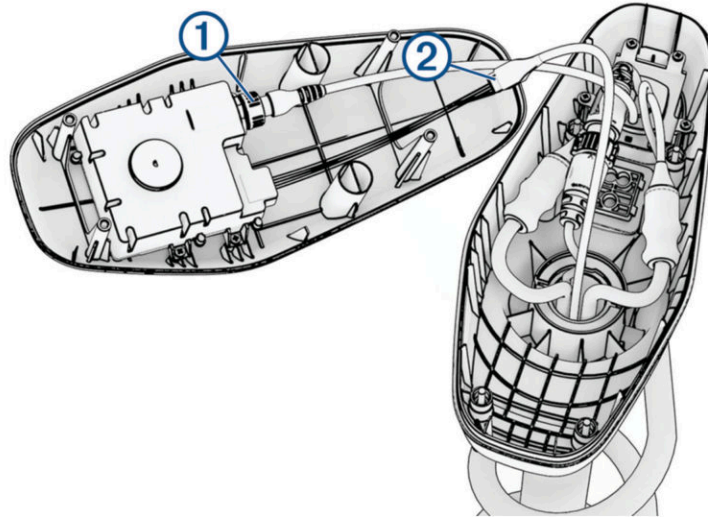

- 2 Release the latch ② and pull the connectors apart to disconnect the motor data cable.
- 3 Liberally apply dielectric grease to both ends of the GPS data connector and the motor data connector.
- 4 Connect the GPS data connector to the antenna box on the new shaft cap lid and tighten the collar.
- 5 Align both sections of the motor data cable connector, and press together to connect them.
- 6 Close the shaft cap lid ([Closing the Shaft Cap, page 65](#)).

Replacing the Shaft Mini-Tumbler and Biasing Bushing

- 1 Remove the shaft mini-tumbler and biasing bushing ([Removing the Shaft Mini-Tumbler and Biasing Bushing with the Shaft Installed, page 38](#)).
- 2 Install the new shaft mini-tumbler and biasing bushing ([Installing the Shaft Mini-Tumbler and Biasing Bushing, page 57](#)).

Replacing the Servo Landing Pad

- 1 Deploy the motor.
- 2 Remove the servo landing pad ([Removing the Servo Landing Pad, page 32](#)).
- 3 Install the new servo landing pad ([Installing the Servo Landing Pad, page 56](#)).

Replacing the Coil Cable and Junction Box

- 1 Disconnect the power cable and transducer cable (if present).
- 2 Remove the mount shrouds (*Removing the Mount Shrouds*, page 27).
- 3 Open the shaft cap (*Opening the Shaft Cap*, page 33).
- 4 Disconnect the cables in the shaft cap (*Disconnecting the Cables in the Shaft Cap*, page 35).
- 5 Remove the coil cable from the shaft cap (*Removing the Coil Cable from the Shaft Cap*, page 35).
- 6 Remove the junction box (*Removing the Coil Cable Junction Box from the Mount Base*, page 44).
- 7 Connect the new junction box (*Connecting the Coil Cable Junction Box to the Mount Base*, page 61).
- 8 Route the new power and transducer cables (*Routing the Power and Transducer Cables Through the Mount*, page 55).
- 9 Install the coil cable in the shaft cap (*Installing the Coil Cable in the Shaft Cap*, page 62).
- 10 Connect the cables in the shaft cap (*Connecting the Cables in the Shaft Cap*, page 63).
- 11 Close the shaft cap (*Closing the Shaft Cap*, page 65).
- 12 Install the mount shrouds (*Installing the Mount Shrouds*, page 68).
- 13 Reconnect the power cable and transducer cable (if present).

Replacing the Mount and Servo Bushings

- 1 Deploy the motor.
- 2 Remove the mount shrouds (*Removing the Mount Shrouds*, page 27).
- 3 Remove the old cradle hardware (*Removing the Cradle Hardware*, page 28).
- 4 Install the cradle hardware with new bushings (*Installing the Cradle Hardware*, page 66).
- 5 Remove the servo landing pad (*Removing the Servo Landing Pad*, page 32).
- 6 Remove the pivot pin (*Removing the Pivot Pin*, page 45).
- 7 Remove the servo housing.
- 8 Install the new bushings in the servo assembly (*Installing the Bushings in the Steering Servo Housing*, page 52).
- 9 Set the servo housing in place.
- 10 Reinstall the pivot pin (*Reinstalling the Pivot Pin*, page 53).
- 11 Connect the steering servo cables (*Connecting the Steering Servo Cables*, page 56).
- 12 Install the servo landing pad (*Installing the Servo Landing Pad*, page 56).
- 13 Install the mount shrouds (*Installing the Mount Shrouds*, page 68).

Replacing the Bottom Shaft Cap Assembly

- 1 Disconnect the power cable.
- 2 Open the shaft cap (*Opening the Shaft Cap*, page 33).
- 3 Disconnect the shaft cap cables (*Disconnecting the Cables in the Shaft Cap*, page 35).
- 4 Remove the coil cable from the shaft cap (*Removing the Coil Cable from the Shaft Cap*, page 35).
- 5 Remove the old shaft cap (*Removing the Shaft Cap*, page 36).
- 6 Install the new shaft cap (*Installing the Shaft Cap*, page 62).
- 7 Install the coil cable in the new shaft cap (*Installing the Coil Cable in the Shaft Cap*, page 62).
- 8 Connect the shaft cap cables (*Connecting the Cables in the Shaft Cap*, page 63).
- 9 Close the shaft cap (*Closing the Shaft Cap*, page 65).
- 10 Reconnect the power cable.

Replacing the Upper Shaft Cap Housing

- 1 Disconnect the power cable.
- 2 Open the shaft cap ([Opening the Shaft Cap, page 33](#)).
- 3 Disconnect the antenna box cables ([Disconnecting the Antenna Box Cables, page 33](#)).
- 4 Remove the antenna box from the old upper shaft cap housing ([Removing the Antenna Box, page 34](#)).
- 5 Install the antenna box on the new upper shaft cap housing ([Installing the Antenna Box, page 64](#)).
- 6 Connect the antenna box cables ([Connecting the Antenna Box Cables, page 64](#)).
- 7 Close the shaft cap ([Closing the Shaft Cap, page 65](#)).
- 8 Reconnect the power cable.

Replacing the Display Panel

- 1 Deploy the motor.
- 2 Remove the mount shrouds ([Removing the Mount Shrouds, page 27](#)).
- 3 Remove the old display panel ([Removing the Display Panel, page 43](#)).
- 4 Install the new display panel ([Installing the Display Panel, page 54](#)).
- 5 Reinstall the mount shrouds ([Installing the Mount Shrouds, page 68](#)).

Replacing the Steering Servo Cables

Before you replace the steering servo cables, you must remove the steering servo housing ([Removing the Existing Steering Servo Housing, page 45](#)).

NOTICE

This procedure exposes the main PCB. Always follow electrostatic discharge (ESD) prevention procedures when opening the steering servo housing. ESD can damage your PCB, and prevent your motor from functioning properly.

- 1 Using a #2 Phillips bit or screwdriver, remove the cable retainer screw ①.



- 2 Remove the cable retainer ②.
- 3 Open the steering servo housing ([Opening the Steering Servo Housing, page 48](#)).

- 4 Disconnect the three cable connectors ③ from the PCB.

NOTICE

The cables and connectors are very fragile. Use extreme care when disconnecting and reconnecting these cables to the PCB to avoid possible damage to the cables and connectors. Only push and pull on the connectors, not the cables.

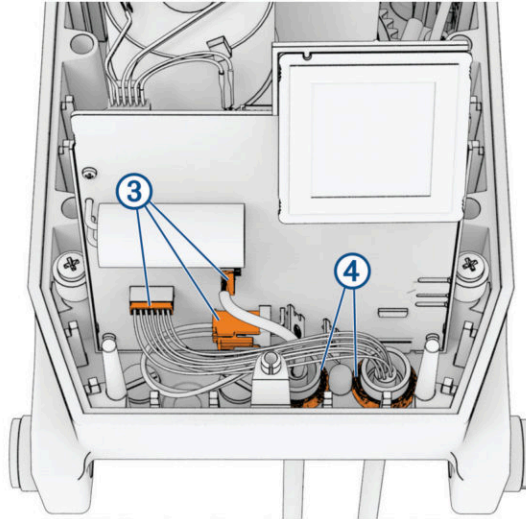

- 5 Pull the old steering servo cables ④ out of the steering servo housing from the bottom.
- 6 Using marine-grade grease, lightly grease the o-rings on each cable boot.
- 7 Route the new steering servo cables through the steering servo case.
NOTE: The cable with the 7-pin connector must be on the right side, and the cable with the 6-pin connector must be in the middle.
- 8 Install the replacement cable retainer and replacement #2 Phillips screw.
- 9 Connect the three new cable connectors to the PCB.
- 10 Close the steering servo housing ([Closing the Steering Servo Housing, page 73](#)).

Replacing the Steering Servo PCB

- 1 Remove the old steering servo PCB ([Removing the Steering Servo PCB, page 49](#)).
- 2 Install the new steering servo PCB ([Installing the Steering Servo PCB, page 72](#)).

Replacing the Shaft Carrier

- 1 Remove the shaft carrier ([Removing the Shaft Carrier, page 50](#)).
- 2 Install the new shaft carrier ([Installing the Shaft Carrier, page 70](#)).

Replacing the Steering Motor Module

- 1 Remove the steering motor module ([Removing the Steering Motor Module, page 50](#)).
- 2 Install the new steering motor module ([Installing the Steering Motor Module, page 71](#)).
- 3 Reset the zero position ([Resetting the Zero Position, page 26](#)).

Replacing the Steering Servo Gasket

Before you replace the steering servo cables, you must remove the steering servo housing ([Removing the Existing Steering Servo Housing, page 45](#)).

NOTICE

This procedure exposes the main PCB. Always follow ESD prevention procedures when opening the steering servo housing. ESD can damage your PCB, and prevent your motor from functioning properly.

- 1 Open the steering servo housing ([Opening the Steering Servo Housing, page 48](#)).
- 2 Remove and discard the old steering servo gasket.
- 3 Clean the channels on both halves of the steering servo housing to remove any dirt or debris.
- 4 Apply a light layer of silicone grease to the new steering servo gasket.
- 5 Install the new steering servo gasket on the lower half of the steering servo housing.

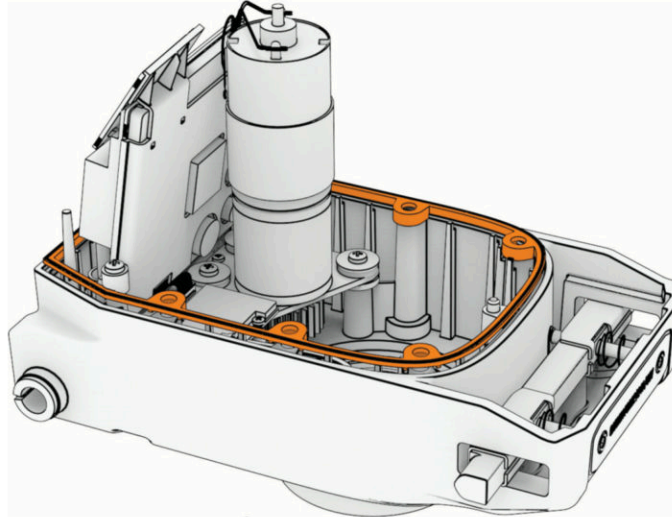

- 6 Close the steering servo housing ([Closing the Steering Servo Housing, page 73](#)).

Resetting the Zero Position

After servicing the steering motor module, you must reset the zero position.

- 1 Deploy the motor.
- 2 Ensure the remote control is paired with the trolling motor.
- 3 On the remote control, select **☰** > **Settings** > **Trolling Motor** > **Steering Alignment**.
- 4 Press **▼** to begin calibration.
The motor automatically calibrates in two processes.

Disassembly Procedures

Removing the Mount Shrouds

- 1 Using a 4 mm hex bit or wrench, remove the screws ① that secure the mount shroud ② to the mount base.

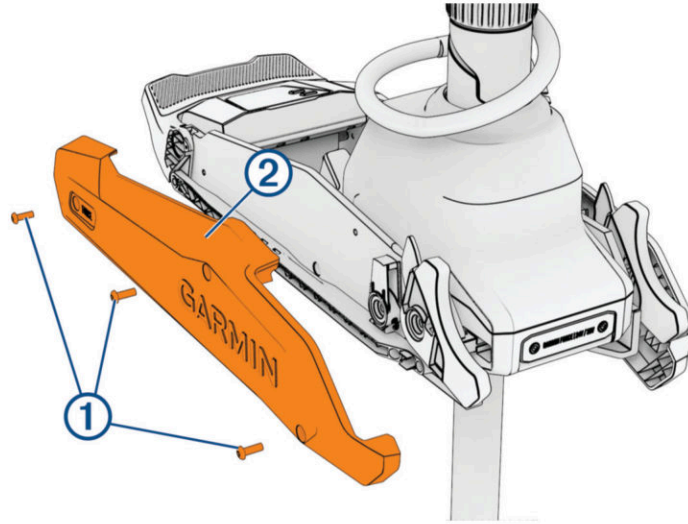

- 2 Remove the mount shroud.
- 3 Repeat these steps to remove the mount shroud on the opposite side.

Removing the Cradle Tension Springs

Before you remove the cradle tension springs, you must remove the mount shrouds ([Removing the Mount Shrouds, page 27](#)).

- 1 Unhook the cradle tension spring ① from the cradle hook ②.

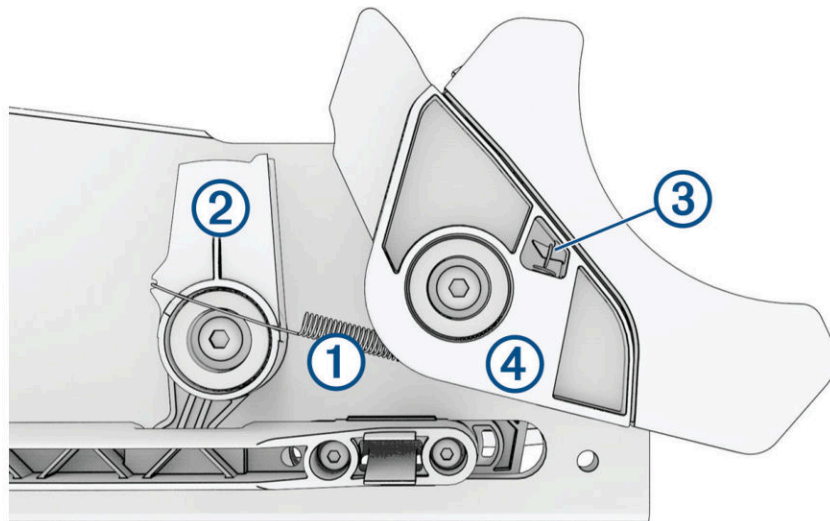

- 2 Using a small flathead screwdriver or a pick, slide the loop on the end of the cradle tension spring ③ off of the hook inside the cradle catch ④.

Removing the Cradle Hardware

Before you remove the cradle hardware, you must remove the mount shrouds (*Removing the Mount Shrouds, page 27*).

- 1 Using a 4 mm hex wrench or bit, remove the M6 screw ① holding the cradle in place, and remove the bushing ②.

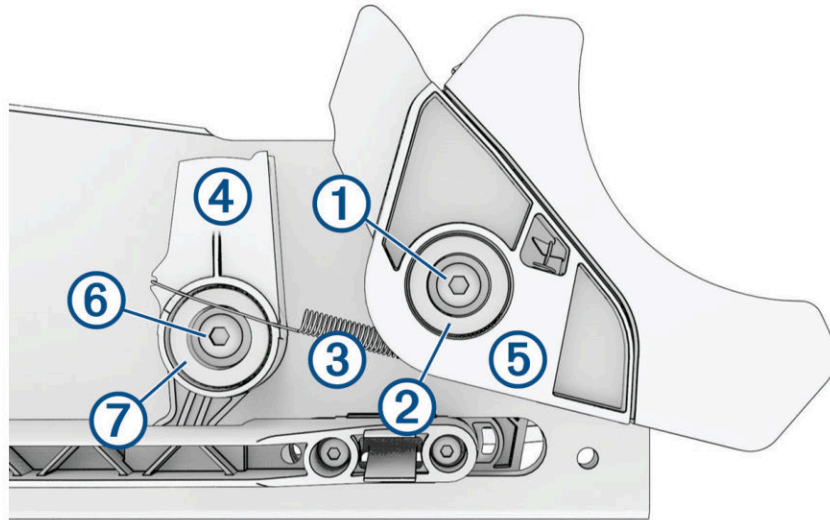

- 2 Unhook the cradle tension spring ③ from the cradle hook ④, and remove the cradle ⑤.
- 3 Using a 4 mm hex wrench or bit, remove the M6 screw ⑥ holding the cradle hook in place, and remove the cradle hook and bushing ⑦.
- 4 Repeat this procedure on the opposite side.

Removing the Latch Pushers

Before you remove the latch pushers, you must remove the latch tension spring (*Removing the Latch Tension Springs, page 29*).

- 1 Using a #2 Phillips bit or screwdriver, remove the screws ① from the latch pusher linkages.

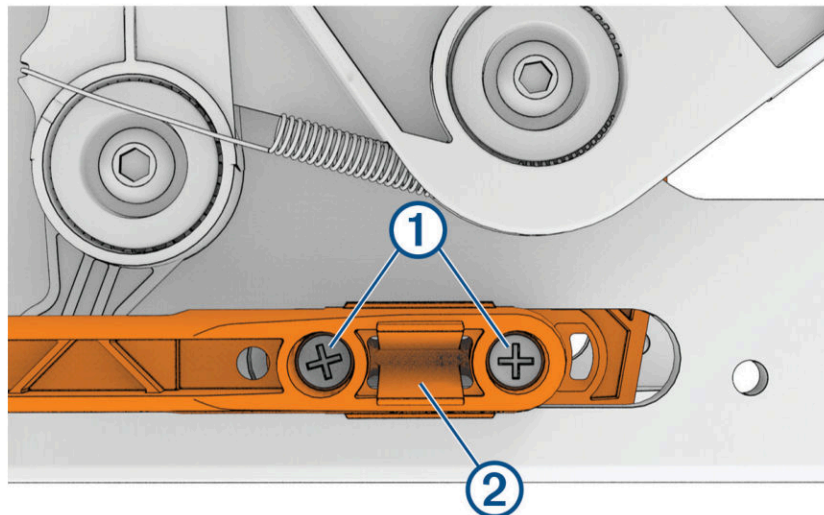

- 2 Pinch the tabs ② on each side to disconnect the latch pusher and release the latch pusher linkage from the mount base.
- 3 Repeat this procedure for the latch pusher and latch pusher linkage on the other side.

Removing the Latch Pusher Linkage

Before you remove the latch pusher linkage, you must remove the latch pushers ([Removing the Latch Pushers, page 28](#)).

Lift the latch pedal straight up ①, and remove the latch pusher linkages from the pedal ②.



Removing the Latch Tension Springs

Before you remove the latch tension springs, you must remove the mount shrouds ([Removing the Mount Shrouds, page 27](#)).

1 Carefully unhook the latch tension spring ① from the pusher linkage ② and latch pedal ③.

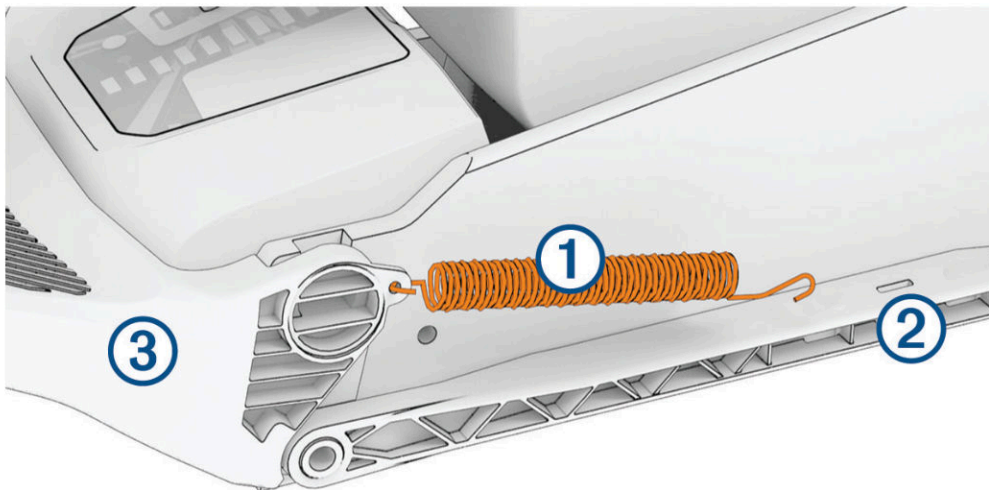

2 Repeat this procedure for the latch tension spring on the other side.

Removing the Latch Pedal

Before you remove the latch pedal, you must remove the latch pusher linkages ([Removing the Latch Pusher Linkage, page 29](#)).

Lift the latch pedal straight up to remove it.

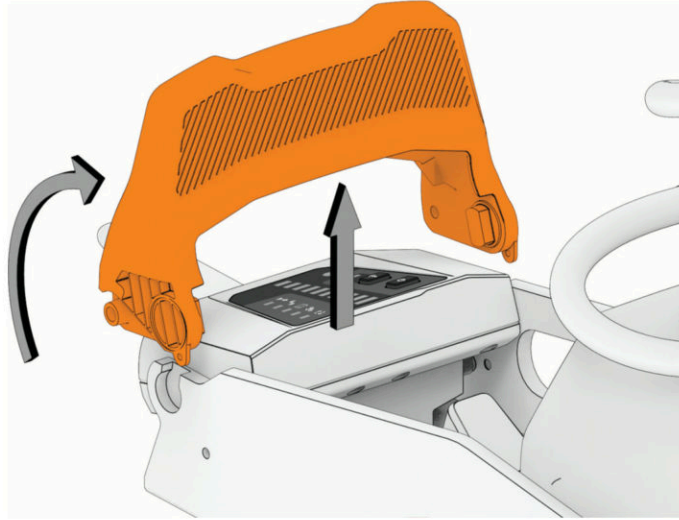

Removing the Release Latch

- 1 With the motor in the stowed position, use a 4 mm hex bit or wrench to remove the two hex head screws ① from the latch spring cover ②.

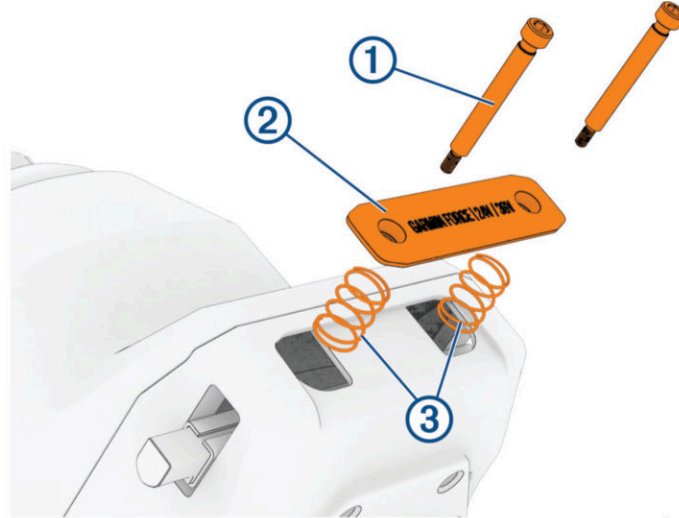

NOTE: The latch spring cover is under spring tension. Take care that you do not lose the cover and springs ③ during disassembly.

- 2 Slide the release latch ④ out of the steering servo housing.



Removing the Servo Landing Pad

- 1 Using a 3 mm hex bit or wrench, remove the two screws ① that secure the servo landing pad ② to the mount base.

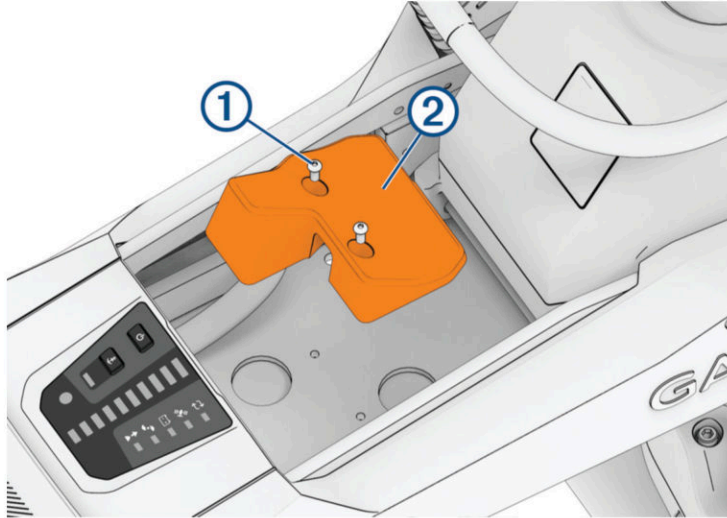

- 2 Remove the landing pad.

Disconnecting the Steering Servo Cables

Before disconnecting the steering servo cables, you must remove the servo landing pad ([Removing the Servo Landing Pad, page 32](#)).

Unscrew the locking collars and disconnect the cables ① from the display panel and junction box.

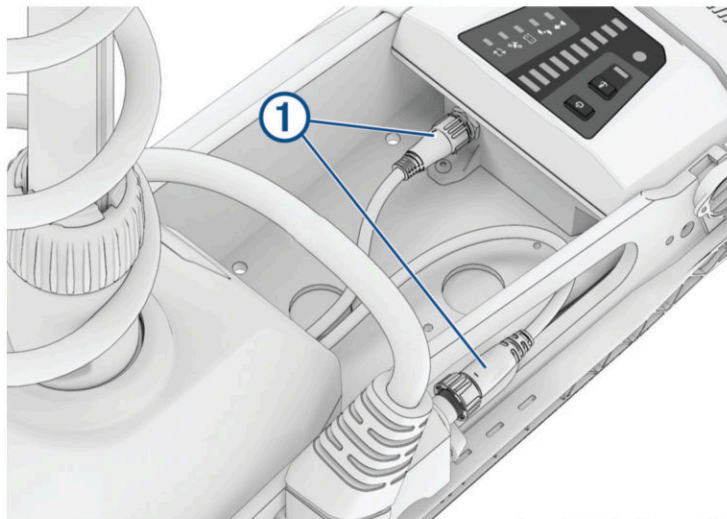

Opening the Shaft Cap

WARNING

Before you open the shaft cap, you must disconnect the motor from the power source. Failure to disconnect the power source can lead to electrical shock or damage to the motor.

- 1 Using a #2 Phillips screwdriver, remove the four screws that secure the lid of the shaft cap.



- 2 Carefully lift up the lid of the shaft cap to access the cable connectors inside.

NOTICE

There are two cables connected to the top of the shaft cap. Take care when opening the shaft cap to avoid damaging the cables or connectors.

Disconnecting the Antenna Box Cables

- 1 Unscrew and disconnect the GPS data connector .
- Ensure the o-ring remains in place inside the connector.

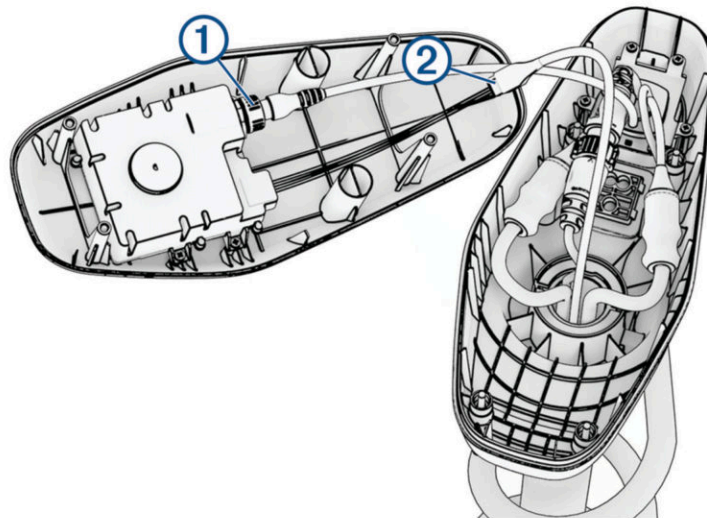

- 2 Release the latch  and pull the connectors apart to disconnect the motor data cable.

NOTICE

To avoid damaging the cable, pull only on the connector body. Do not pull on the wire itself.

Removing the Antenna Box

- 1 Using a # 1 Phillips bit or screwdriver, remove the four screws that secure the antenna box ① to the upper shaft cap housing.

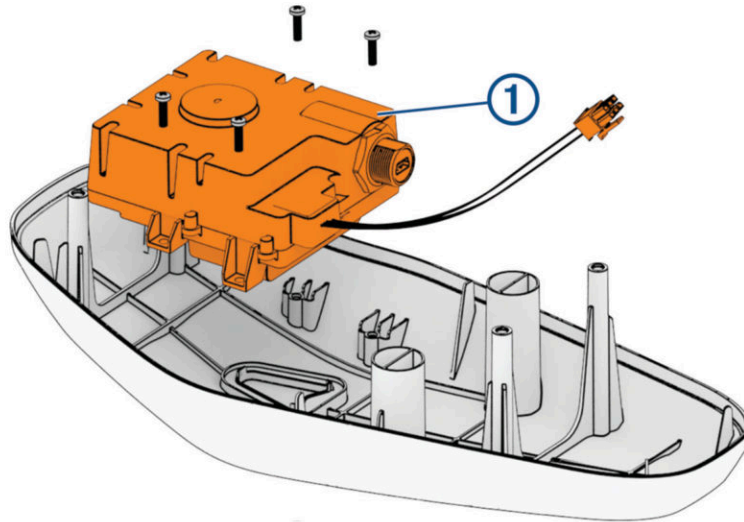

- 2 Remove the antenna box.

Removing the LiveScope™ Transducer Cable from the Shaft Cap

NOTE: Not all models have a LiveScope transducer cable routed through the trolling motor shaft.

- 1 If it is present, disconnect the transducer cable from the sonar module or from the transducer extension cable.
- 2 Remove the tape securing the transducer cable to the coiled power cable.
- 3 Straighten the transducer cable so you can easily pull it through the shaft cap.
- 4 Push from the inside out to remove the square grommet ① that holds the transducer cable ② in the shaft cap.



- 5 Remove the grommet from the transducer cable.
The grommet is split on one side to make it easy to remove from the cable.
You should keep the grommet in a safe place, because you must reinstall it later.
- 6 Remove the threaded collar from the transducer cable.
- 7 Feed the transducer cable through the shaft cap from the outside in until it is no longer routed through the square hole.

Removing the Coil Cable from the Shaft Cap

Before you can remove the coil cable from the shaft cap, you must disconnect the cables in the shaft cap (*Disconnecting the Cables in the Shaft Cap*, page 35).

TIP: Count and record the number of coils in the coil cable before removing it to simplify reinstallation.

- 1 Using a #1 Phillips bit or screwdriver, remove the four screws that secure the coil cable bracket ①, and slide the bracket off of the cable boot.

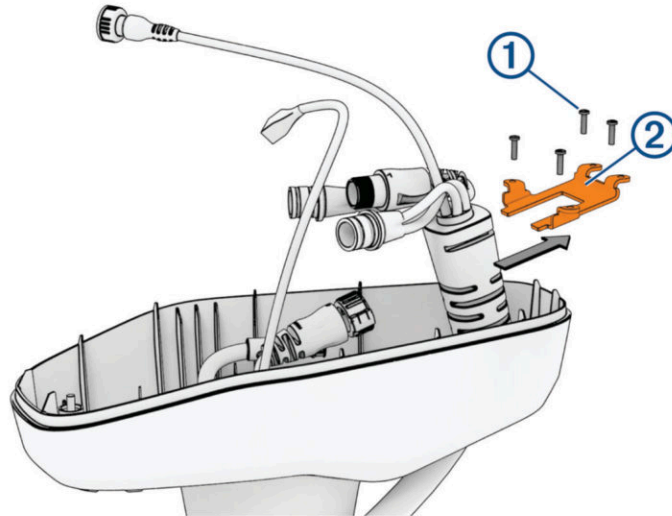

- 2 Pull the coil cable out of the shaft cap to remove it.

Disconnecting the Cables in the Shaft Cap

- 1 Unscrew and disconnect the GPS data connector ①.
Ensure the o-ring remains in place inside the connector.

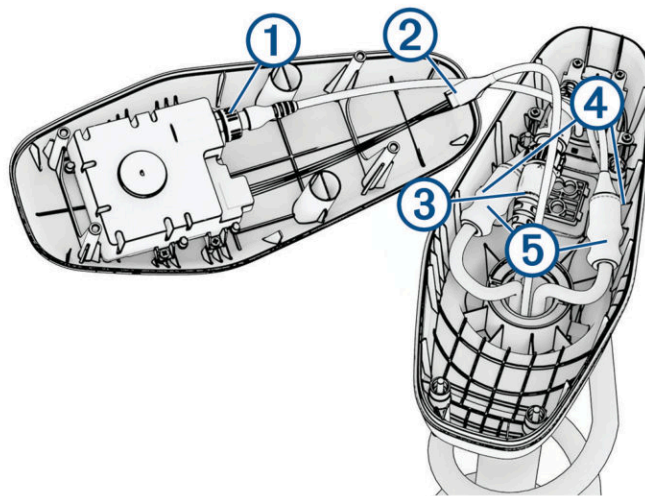

- 2 Release the latch ② and pull the connectors apart to disconnect the motor data cable.

NOTICE

To avoid damaging the cable, pull only on the connector body. Do not pull on the wire itself.

- 3 Unscrew and disconnect the transducer cable ③ (if present).
- 4 Carefully cut off the zip ties ④.
- 5 Slide down the protective coverings ⑤ on the power cables.
- 6 Using a 2.5 mm allen wrench, loosen the four set screws on the two power cables.

- 7 Disconnect the power cables.
- 8 Remove the protective coverings from the power cables.

Removing the Shaft Cap

- 1 Take a picture or count and write down the number of coils in the coil cable that wraps around the shaft. When re-assembling the shaft and shaft cap, you must use the same number of coils around the shaft.
- 2 Using a #3 Phillips screwdriver, remove the $\frac{1}{4}$ -20 bolts ①, lock washers, and nuts ② that secure the shaft cap to the shaft.

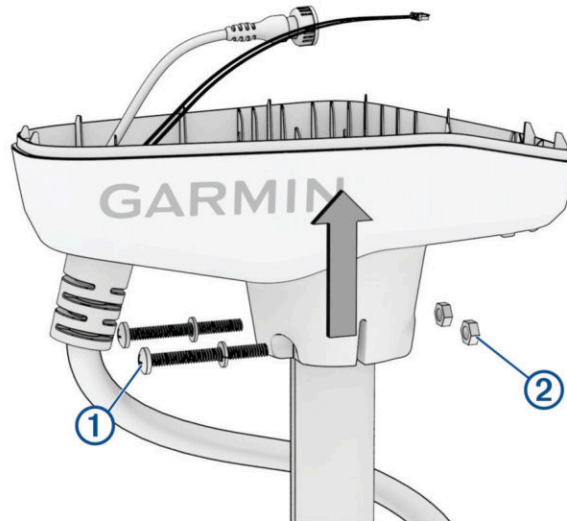

You should keep these bolts and nuts in a safe place, because you must use them when reinstalling the shaft cap.

- 3 Lift up the shaft cap to disconnect it from the shaft.
- 4 Pull the cables completely through the shaft cap, taking care to avoid damaging the cable connectors when you pull them through.

Removing the Depth-Adjustment Assembly

Before you remove the depth-adjustment assembly, you should support the motor or ensure the motor is in the stowed position.

⚠ CAUTION

Loosening the depth-adjustment assembly with the motor in the deployed position allows the motor and shaft to drop free of the steering servo. Support the motor while loosening the depth-adjustment assembly or keep the motor in the stowed position when removing the depth-adjustment assembly to prevent damage to or loss of the motor and to prevent personal injury.

Turn the depth-adjustment assembly counter-clockwise to loosen it ①, and slide both pieces off of the shaft ②.

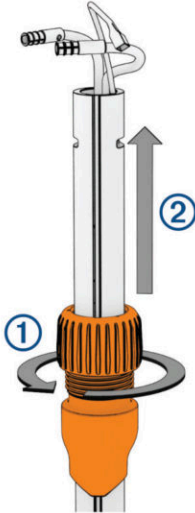

Removing the Shaft Mini-Tumbler and Biasing Bushing with the Shaft Installed

You can remove the shaft mini-tumbler and biasing bushing from the steering servo housing while the shaft is installed.

- 1 Stow the motor.
- 2 Using a #2 Phillips bit or screwdriver, remove the screw ① from the biasing bushing ②.

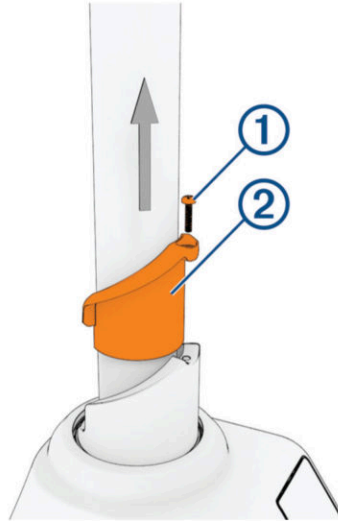

- 3 Slide the biasing bushing up and pull it off of the shaft.
- 4 Deploy the motor, ensuring the weight of the motor is resting on a stable surface and not on the depth-adjustment assembly.
- 5 Align the shaft mini-tumbler ③ with the lowest point of the shaft carrier.

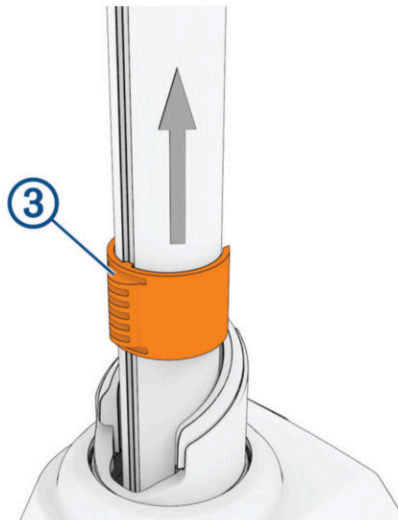

- 6 Using a flat-head screwdriver or similar tool, slide the shaft mini-tumbler up from the steering servo, and pull it off of the shaft.

Removing the Shaft Mini-Tumbler and Biasing Bushing

Removing the mini-tumbler and biasing bushing from the steering servo housing makes it easier to install the shaft later.

- 1 Using a #2 Phillips bit or screwdriver, remove the screw ① from the biasing bushing ②.

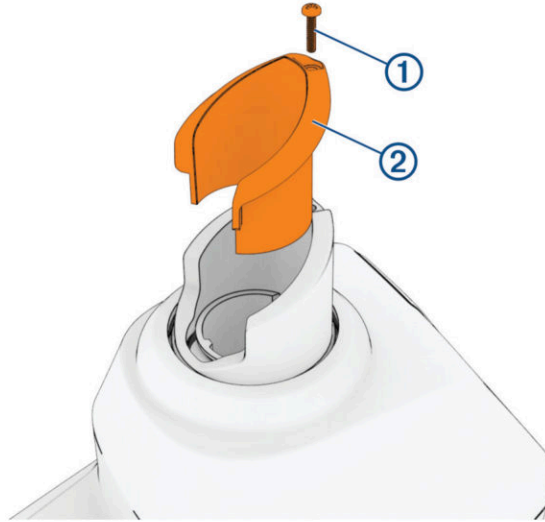

- 2 Pull out the biasing bushing.
- 3 Slide the shaft mini-tumbler ③ out of the steering servo.

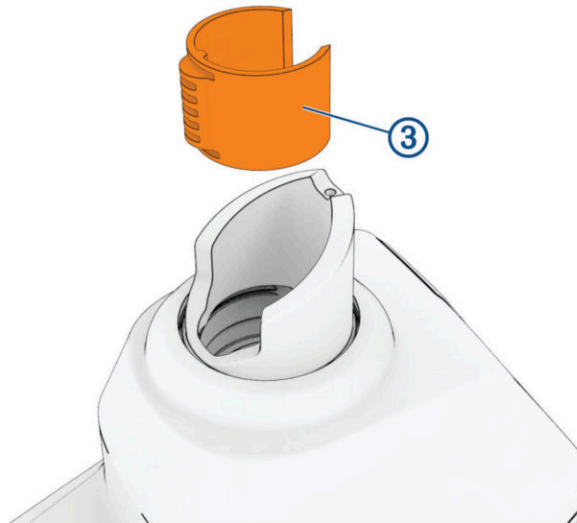

Removing the Shaft from the Steering Servo Housing

⚠ CAUTION

Without the depth-adjustment assembly in place, the motor and shaft are free to drop free of the steering servo. Support the motor while removing the shaft to prevent personal injury or damage to the motor. Due to the weight of the motor and shaft, this procedure is best performed with two people.

- 1 Rotate the steering servo and shaft to the stowed position.

NOTE: You must ensure the coil cable ① is not pinched under the steering servo when stowing.

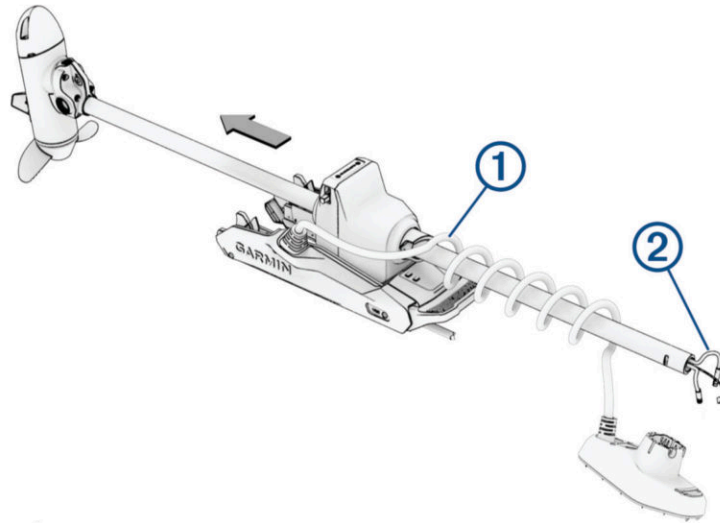

- 2 Slide the shaft and motor out of the steering servo, taking care not to damage the skeg and transducer or snag the cables or connectors ② as you pull it through.

NOTE: To avoid damage to the motor, do not pull on the cables.

Removing the Skeg and Nose Cone

- 1 Using a 4 mm hex bit or wrench, remove the four screws ① that secure the skeg ② to the propeller drive motor.

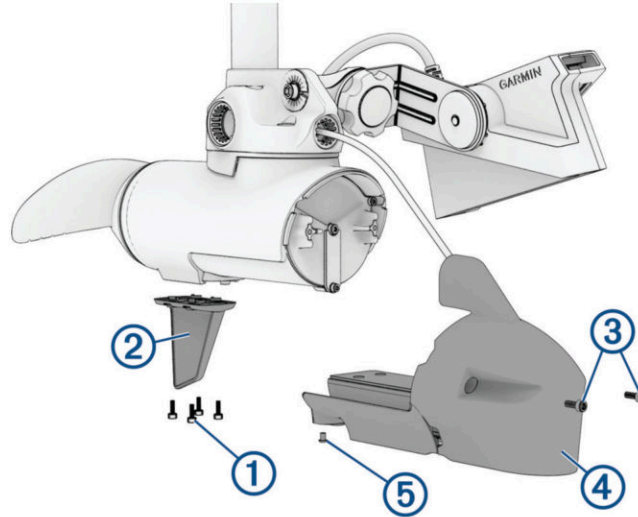

- 2 Remove the skeg.
- 3 Using a 4 mm hex bit or wrench, remove the two screws ③ that secure the front of the nose cone ④ to the propeller drive motor.
- 4 Using a 3 mm hex bit or wrench, remove the single screw ⑤ that secures the bottom of the nose cone to the propeller drive motor.

NOTE: You should keep all of these screws and parts in a safe place, because you must reinstall them when reassembling the skeg and nose cone.

Removing the Propeller Drive Motor

NOTICE

When removing the propeller drive motor from the shaft, you must pull the cables themselves, and not the motor. Pulling on the propeller drive motor may damage the cable connections inside the motor. The motor should not be supported by the cables alone. Supporting the motor only with the cables may damage the motor.

- 1 Using a 5 mm hex bit or wrench, remove the six screws ① that secure the shaft base to the propeller drive motor.

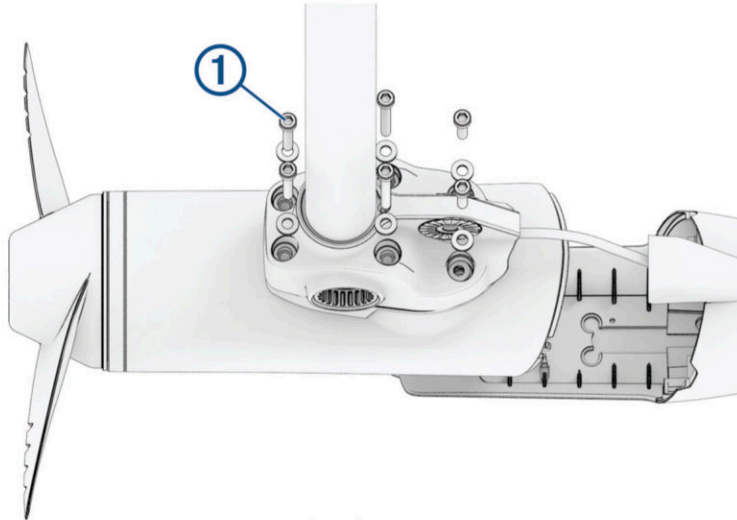

- 2 Using the tool ② included in the shaft and motor hardware service kit, remove the recessed nut ③ that secures the transducer cable to the shaft.

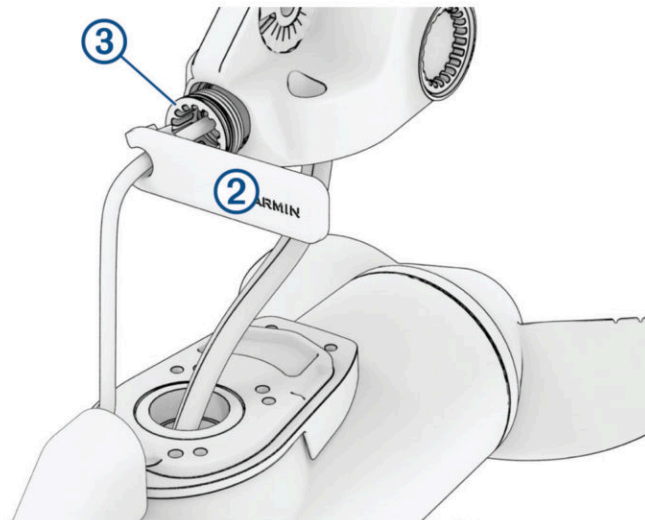

- 3 Straighten the cables at the top of the shaft, and slowly pull the propeller drive motor away from the shaft base until you can see the power and data cables ④ connected to the propeller drive motor.

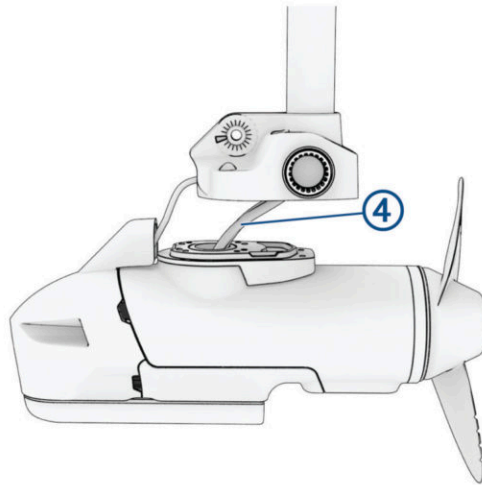

- 4 Push the transducer cable grommet out from inside the downshaft adapter.
- 5 While supporting the weight of the motor, slowly pull the cables through the shaft, taking care that the connectors do not get caught on the top of the shaft.
The power and transducer cables should pull through the shaft completely.

Removing the Display Panel

Before you can remove the display panel from the mount base, you must remove the mount shrouds ([Removing the Mount Shrouds, page 27](#)).

- 1 Deploy the motor.
- 2 Disconnect the data cable ①.

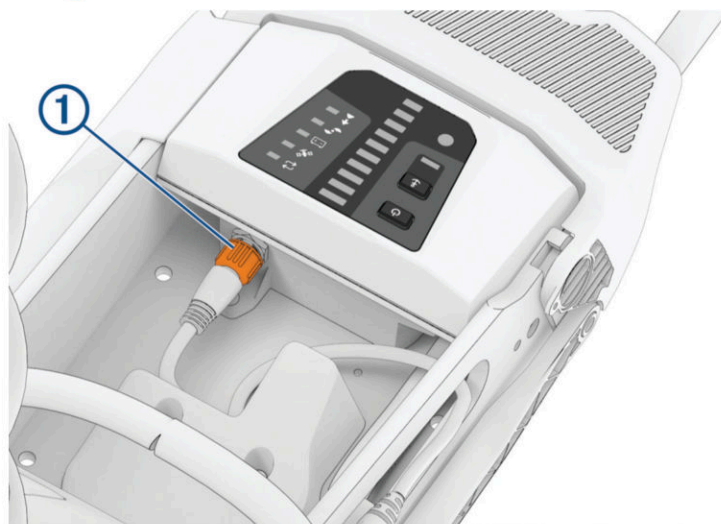

- Using a 3 mm hex bit or wrench, remove the hex screw ② beneath the data connector.



- Using a #2 Phillips bit or screwdriver, remove the side screw ③ from the display panel.
- Slide the display panel back toward the latch pedal and lift it out.

Removing the Coil Cable Junction Box from the Mount Base

Before you can remove the coil cable junction box, you must remove the mount base shrouds ([Removing the Mount Shrouds, page 27](#)).

TIP: Count and record the number of coils in the coil cable before removing it to simplify reinstallation.

- Disconnect the data cable ① from the port on the coil cable junction box.

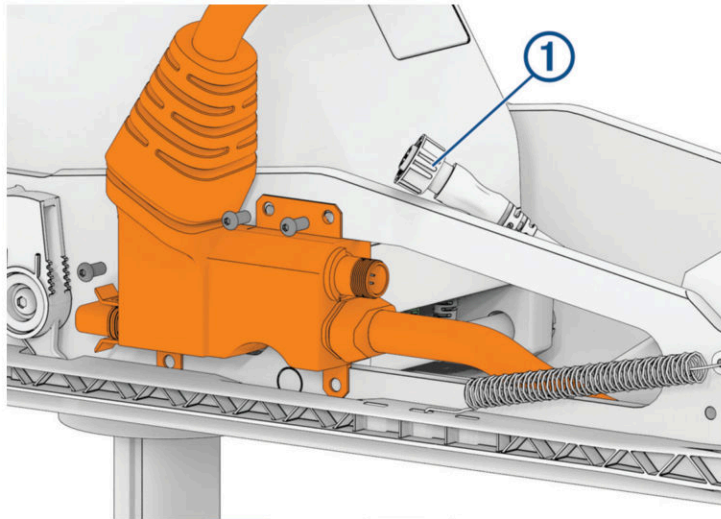

- Using a 3 mm hex bit or screwdriver, remove the three screws that secure the coil cable junction box to the mount base.
- If a transducer extension is present, disconnect it.
- Pull the coil cable junction box away from the mount base to remove it.
- Pull the power cable through the mount base.

Removing the Existing Steering Servo Housing

- 1 Remove the mount shrouds (*Removing the Mount Shrouds*, page 27).
- 2 Open the shaft cap (*Opening the Shaft Cap*, page 33).
- 3 Disconnect the cables in the shaft cap (*Disconnecting the Cables in the Shaft Cap*, page 35).
- 4 Remove the shaft cap (*Removing the Shaft Cap*, page 36).
- 5 Remove the depth-adjustment assembly (*Removing the Depth-Adjustment Assembly*, page 37).
- 6 Remove the shaft from the steering servo housing (*Removing the Shaft from the Steering Servo Housing*, page 40).
- 7 Remove the shaft mini-tumbler and biasing bushing (*Removing the Shaft Mini-Tumbler and Biasing Bushing*, page 39).
- 8 Remove the servo landing pad (*Removing the Servo Landing Pad*, page 32).
- 9 Remove the pivot pin (*Removing the Pivot Pin*, page 45).

Removing the Steering Servo

With the pivot pin removed, lift the steering servo out of the mount.

Removing the Pivot Pin

While pressing down on the latch pusher ①, push the pivot pin ② out of one side and remove it from the mount base.

⚠ CAUTION

The steering servo, shaft, and motor (if present) are free to shift once the pivot pin is removed. Support the steering servo housing and all attached components when removing the pivot pin to prevent property damage and personal injury.

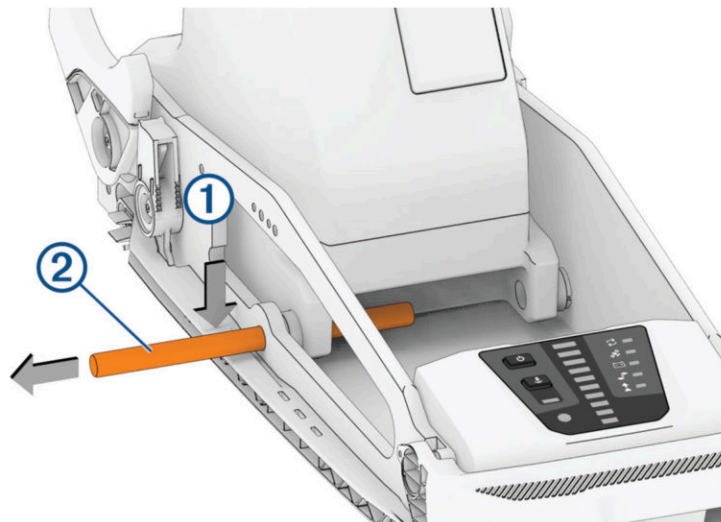

Removing the Propeller

- 1 Using a $\frac{9}{16}$ in (15 mm) socket, remove the nut ① that secures the propeller.

TIP: Keep the propeller in the horizontal position throughout this procedure to prevent the propeller pin from falling out when you remove the propeller.

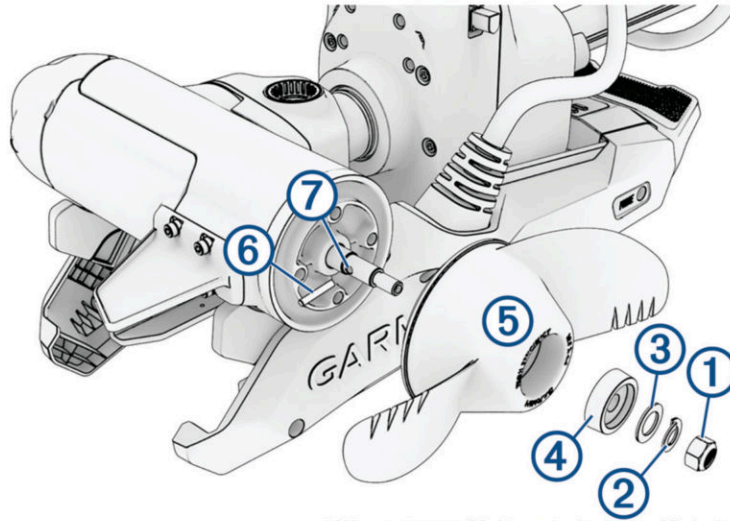

- 2 Remove the lock washer ②, flat washer ③, anode ④, and propeller ⑤.
- 3 Service the anode, if necessary ([Servicing the Anodes](#), page 7).
- 4 Remove the pin ⑥ from the propeller motor shaft ⑦.

Removing the Skeg

Using a 4 mm hex bit or wrench, remove the four screws securing the skeg to the propeller drive motor.

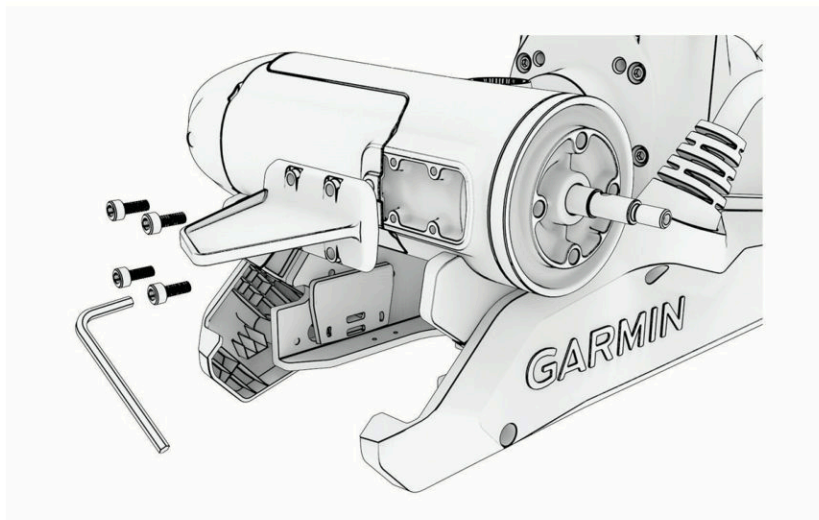

Removing the Transducer

Before you can remove the transducer, you must remove the nose cone ([Removing the Skeg and Nose Cone](#), page 41).

- 1 Using a 3 mm hex bit or driver, remove the four screws ① that secure the transducer to the nose cone.

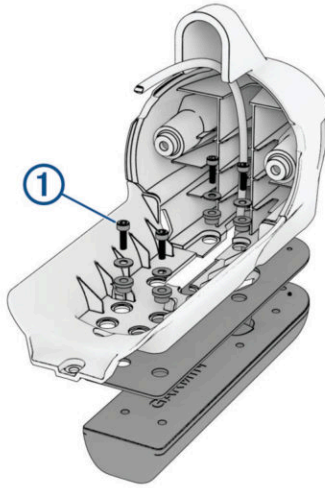

When replacing the transducer, you should dispose of the four screws. New screws, washers, and bushings are provided in the transducer replacement kit.

- 2 Remove the transducer and neoprene pad from the nose cone.

When replacing the transducer, you should dispose of the neoprene pad. A new pad is provided in the transducer replacement kit.

Opening the Steering Servo Housing

Before you can open the steering servo housing, you must remove the shaft ([Removing the Shaft from the Steering Servo Housing, page 40](#)) and the steering servo housing ([Removing the Existing Steering Servo Housing, page 45](#)).

NOTICE

Only service technicians at a Garmin authorized service center should open the steering servo housing. Anyone other than an authorized technician opening or working inside the steering servo housing voids the warranty.

This procedure exposes the main PCB. Always follow electrostatic discharge (ESD) prevention procedures when opening the steering servo housing. ESD can damage your PCB, and prevent your motor from functioning properly.

- 1 Using a 5 mm hex bit or wrench, remove the six screws and washers on the bottom of the steering servo housing.



- 2 Turn the steering servo housing over.
- 3 Carefully and evenly remove the top of the steering servo housing.

Removing the Steering Servo PCB

NOTICE

This procedure exposes the main PCB. Always follow ESD prevention procedures when opening the steering servo housing. ESD can damage your PCB, and prevent your motor from functioning properly.

- 1 Disconnect the three servo cable connectors ① and the motor connector ②.

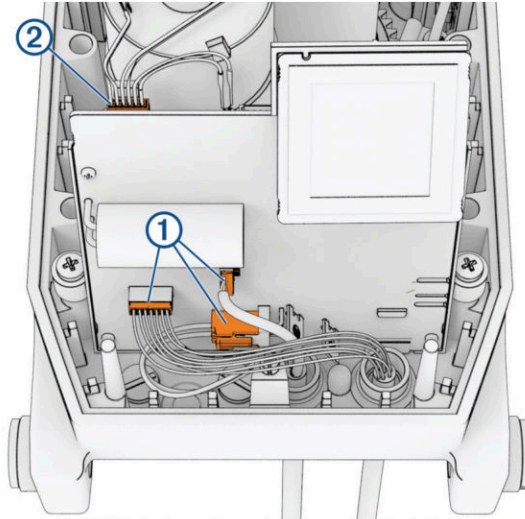

NOTICE

The cables and connectors are very fragile. Use extreme care when disconnecting and reconnecting these cables to the PCB to avoid possible damage to the cables and connectors. Only pull and push on the connectors, not the cables.

- 2 Disconnect the position sensor connector ③.

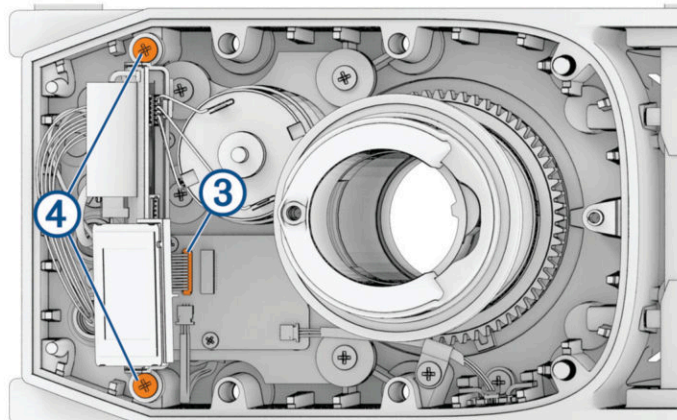

- 3 Using a #2 Phillips screwdriver or bit, remove the two screws securing the PCB ④.
- 4 Carefully lift the PCB straight up.

Removing the Steering Motor Module

Before you can remove the steering motor module, you must remove the PCB ([Removing the Steering Servo PCB, page 49](#)).

NOTICE

This procedure exposes the main PCB. Always follow ESD prevention procedures when opening the steering servo housing. ESD can damage your PCB, and prevent your motor from functioning properly.

- 1 Disconnect the position sensor connectors ①.

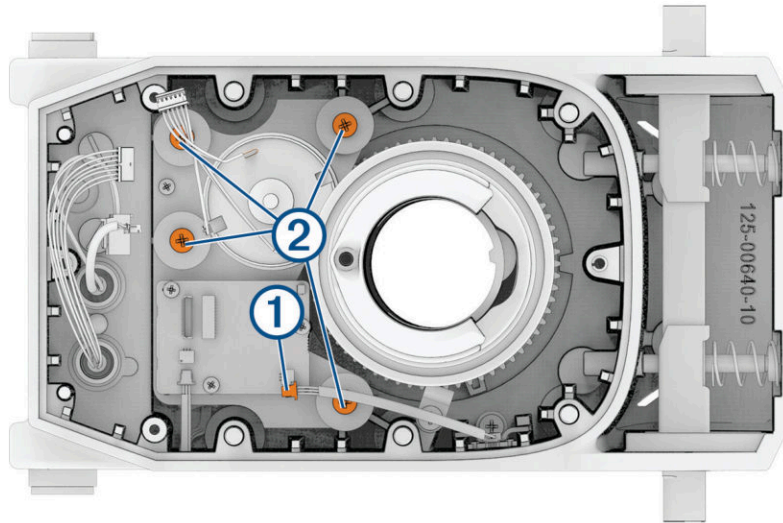

- 2 Using a #2 Phillips bit or screwdriver, remove the four screws ② securing the steering motor module.
- 3 Carefully lift straight up on the steering motor module, using even pressure.

Removing the Shaft Carrier

Before you can remove the shaft carrier and gear, you must open the steering servo housing ([Opening the Steering Servo Housing, page 48](#)) and remove the steering motor module ([Removing the Steering Motor Module, page 50](#)).

Carefully lift the shaft carrier straight up using even pressure, keeping the components in place.

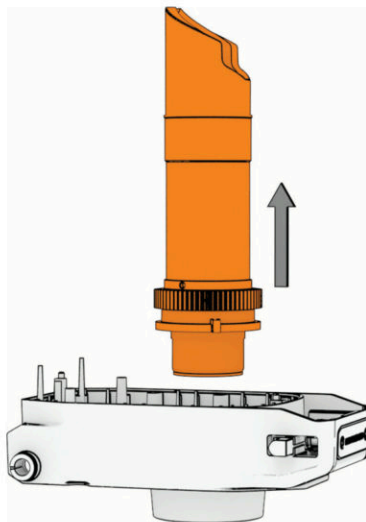

NOTICE

The key is not fixed to the shaft carrier, and may fall out when you remove the shaft carrier. The motor will not function properly without the key in place. Take care to save this key.

Assembly Procedures

Installing the Release Latch

- 1 Apply marine grease to the release latch ①.



- 2 Ensure the bushings ② are in place on the latch as pictured, aligning the holes in the bushings with the holes in the latch.
- 3 Slide the latch in place in the steering servo, rounded side down.
- 4 Place the springs ③ over the latch holes.



- 5 Place the latch cover ④ on the springs, lining up the holes, and insert the latch cover screws ⑤.
- 6 Apply light pressure to the latch cover and secure the latch cover screws using a 4 mm hex bit or wrench.

Installing the Bushings in the Steering Servo Housing

1 Remove the two bushings ① from the existing steering servo housing.

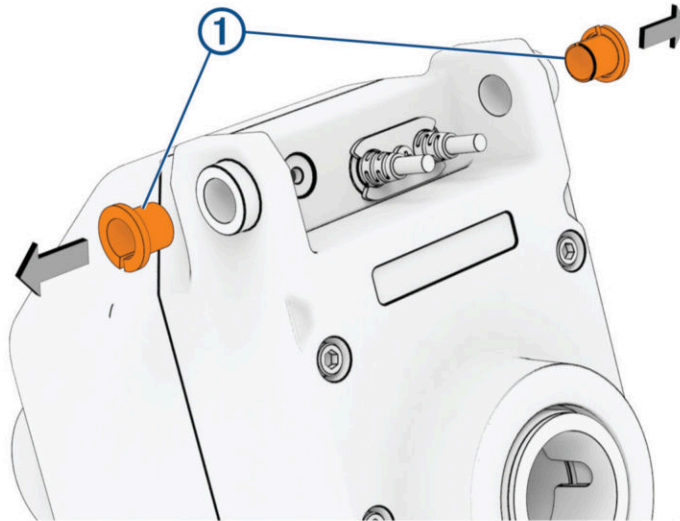

2 Clean all dirt and debris off of the bushings and out of the steering servo housing holes.

3 Apply synthetic or marine grade general-purpose grease to the outside of the bushings ②.

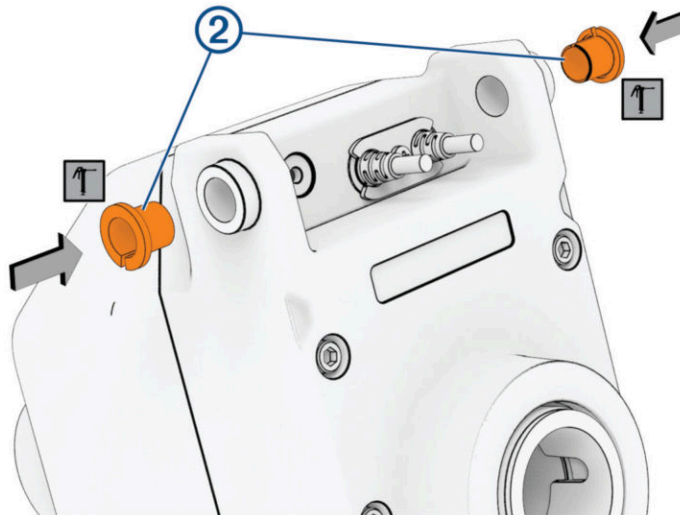

4 Insert the bushings into the steering servo housing.

Installing the Replacement Steering Servo

- 1 Remove the bushings from the previous steering servo housing and install them in the new steering servo housing (*Installing the Bushings in the Steering Servo Housing*, page 52).
- 2 Reinstall the pivot pin (*Reinstalling the Pivot Pin*, page 53).
- 3 Connect the steering servo cables (*Connecting the Steering Servo Cables*, page 56).
- 4 Install the servo landing pad (*Installing the Servo Landing Pad*, page 56).
- 5 Install the shaft in the steering servo housing (*Installing the Shaft in the Steering Servo Housing*, page 60).
- 6 Install the shaft mini-tumbler and biasing bushing (*Installing the Shaft Mini-Tumbler and Biasing Bushing*, page 57).
- 7 Install the depth-adjustment collar (*Reinstalling the Depth-Adjustment Assembly*, page 57).
- 8 Install the shaft cap (*Installing the Shaft Cap*, page 62).
- 9 Connect the cables in the shaft cap (*Connecting the Cables in the Shaft Cap*, page 63).
- 10 Close the shaft cap (*Closing the Shaft Cap*, page 65).
- 11 Install the mount shrouds (*Installing the Mount Shrouds*, page 68).

Reinstalling the Pivot Pin

Before you reinstall the pivot pin, you should ensure the steering servo bushings are installed in the steering servo.

- 1 Place the replacement steering servo in the mount base.
- 2 Press down the latch pusher ①.

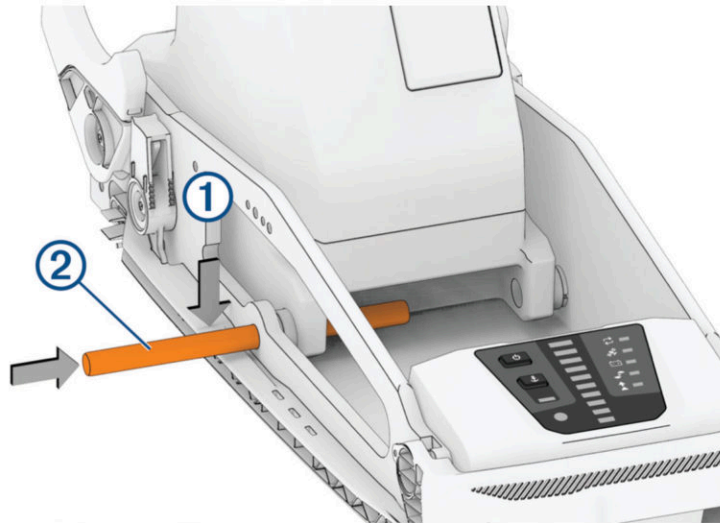

- 3 Push the pivot pin ② through the mount base and the steering servo.

NOTICE

To avoid damage to the steering servo cables, ensure the cables are routed underneath the pivot pin.

Installing the Display Panel

- 1 Slide the display panel into position on the mount base.
- 2 Using a #2 Phillips bit or screwdriver, install the side screw ① through the mount base into the display panel.

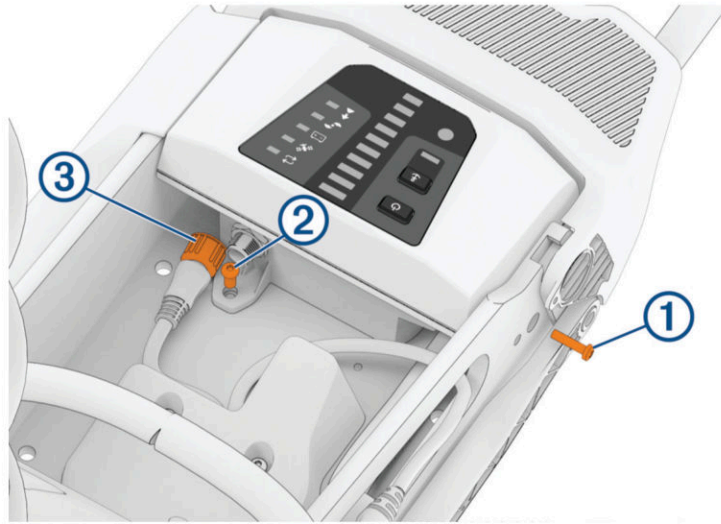

- 3 Using a 3 mm hex bit or wrench, install the hex screw ② beneath the data connector.
- 4 Apply dielectric grease to the data cable ③ and ensure the o-ring is still in place.
- 5 Connect the data cable.

Routing the Power and Transducer Cables Through the Mount

Before you route the cables, you must remove the mount shrouds (*Removing the Mount Shrouds*, page 27).

NOTICE

To avoid damaging the power and transducer cables when deploying and stowing the trolling motor and to avoid interference with the GPS and heading sensors in the motor, you must route the power cable and the transducer cable (if present) through the left (port) side of the mount. You must not route the power and transducer cables through the right (starboard) side of the mount.

TIP: To determine the left (port) side of the mount, stand in a location where you can read the information on the display panel.

- 1 Place the motor in the deployed position.
- 2 Route the transducer cable (if present) and the power cable ① through the channel along the left (port) side of the mount.

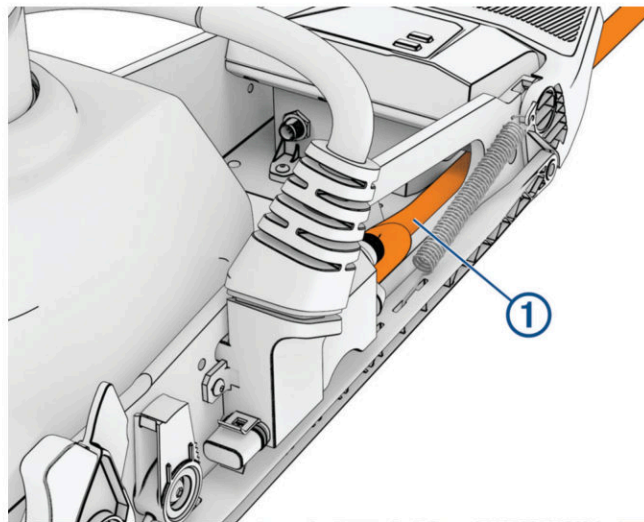

TIP: If you are routing a transducer cable and a power cable, you should route the transducer cable first to prevent snagging.

- 3 Route the power cable through the channel below the data cable.
- 4 If present, secure the transducer cable to the power cable with a clip or tape, ensuring the transducer cable is routed between the power cable and the inside of the mount.
- 5 Leaving a rounded bend in the power cable, route it under the foot pedal ②.

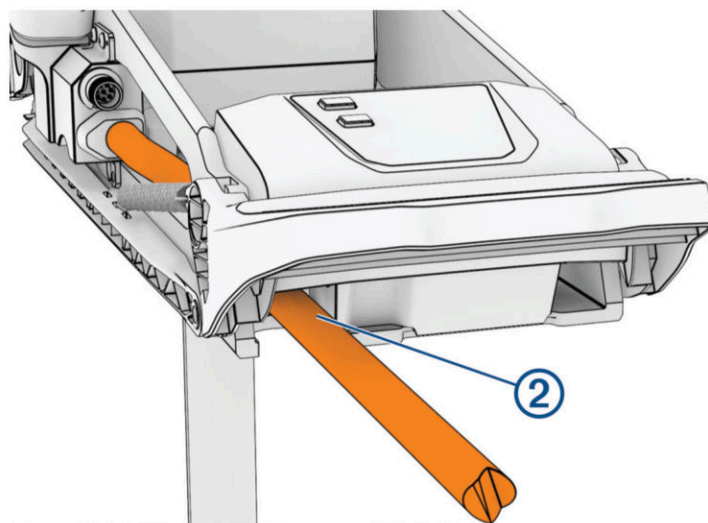

Connecting the Steering Servo Cables

- 1 Fill the female connectors on the control panel and coil cable junction box with dielectric grease.
- 2 Connect the cables ① to the coil cable and the control panel.

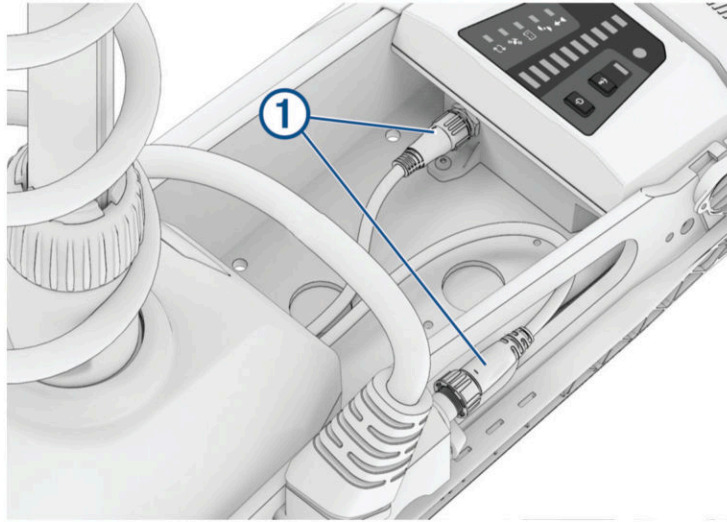

- 3 Tighten the locking collars to secure the cables.

Installing the Servo Landing Pad

- 1 Install the servo landing pad ①, and ensure the cables fit flat in the groove under the servo landing pad and are not twisted or compressed.

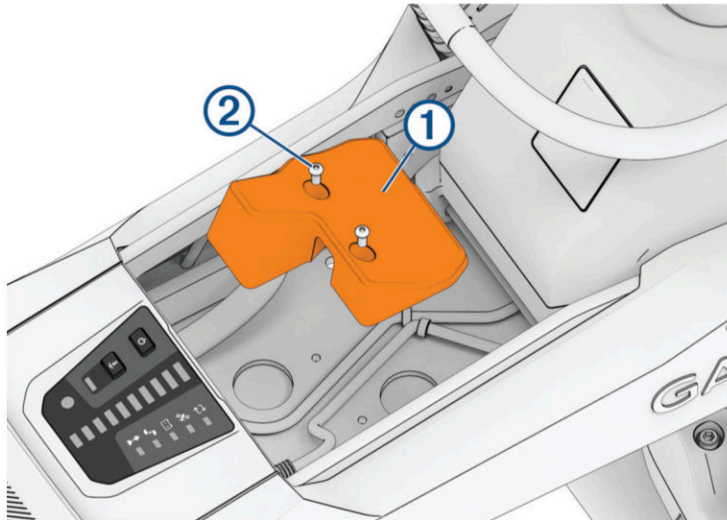

TIP: The molded collars on the cables should be in front of the servo landing pad when installed.

NOTICE

Pinching the cables may result in damage to the cables.

- 2 Secure the servo landing pad to the mount base using the screws ② you removed earlier.

Reinstalling the Depth-Adjustment Assembly

Before you install the depth-adjustment assembly, you should support the motor or ensure the motor is in the stowed position.

⚠ CAUTION

Placing the motor in the deployed position without installing the depth-adjustment assembly allows the motor and shaft to drop free of the steering servo. Support the motor while reinstalling the depth-adjustment assembly or keep the motor in the stowed position when reinstalling the depth-adjustment assembly to prevent damage to or loss of the motor and to prevent personal injury.

- 1 Align the key in the assembly with the groove in the shaft.
- 2 Slide both pieces of the depth-adjustment assembly onto the shaft ①.

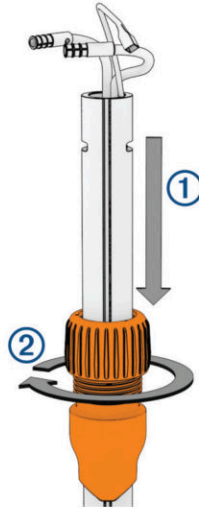

- 3 Turn the depth-adjustment assembly clockwise to tighten it ②.

Installing the Shaft Mini-Tumbler and Biasing Bushing

- 1 Align the ridge on the mini-tumbler ① with the notch on the shaft ②, and snap it onto the shaft.

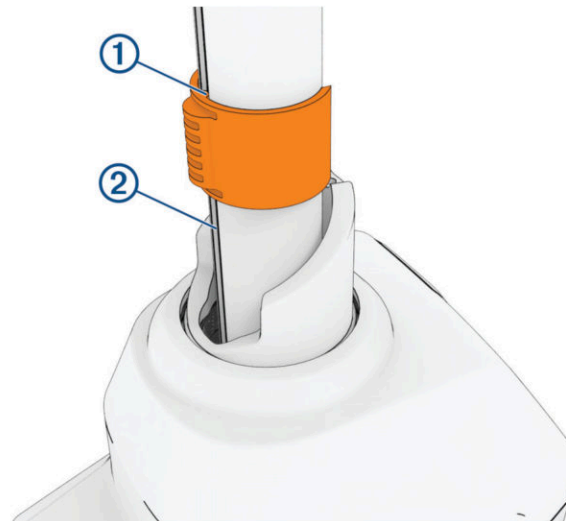

- 2 Slide the mini-tumbler into position in the steering servo.

- 3 Reinstall the biasing bushing ③ around the shaft.



- 4 Using a #2 Phillips bit or screwdriver, secure the biasing bushing with the screw ④ you removed earlier.

Feeding the Cables Through the Shaft

- 1 Place the grommet nut ① over the transducer cable ② with the threaded side facing the downshaft adapter.

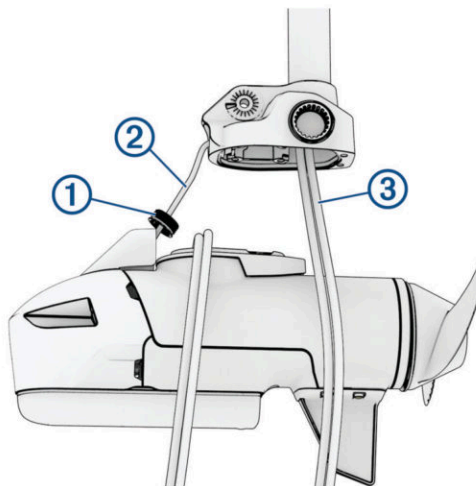

- 2 Feed the transducer cable a few feet into the shaft through the front hole of the downshaft adapter.
- 3 Bundle the power cables ③ and feed them completely through the shaft with the transducer cable.

Installing the Propeller Drive Motor

Before you can install the propeller drive motor in the shaft, you must route the cables through the shaft ([Feeding the Cables Through the Shaft, page 58](#)).

- 1 Using canned compressed air or an air compressor, blow out any dirt or debris in the six threaded holes on the top of the propeller drive motor.
- 2 Gently feed the cables the rest of the way through the shaft.

NOTICE

When feeding the cables, you must pull on the cable and not on the cable connectors. Pulling the cable connectors may damage the connectors.

- 3 Prepare the six bolts ① in the kit by placing a washer ② and a 4.75 mm ($3/16$ in.) O-ring ③ on each one.
- NOTE:** There are three different bolt lengths. Make sure the bolts are in the positions shown in the illustration before tightening. The bolt length corresponds to the downshaft adapter height.

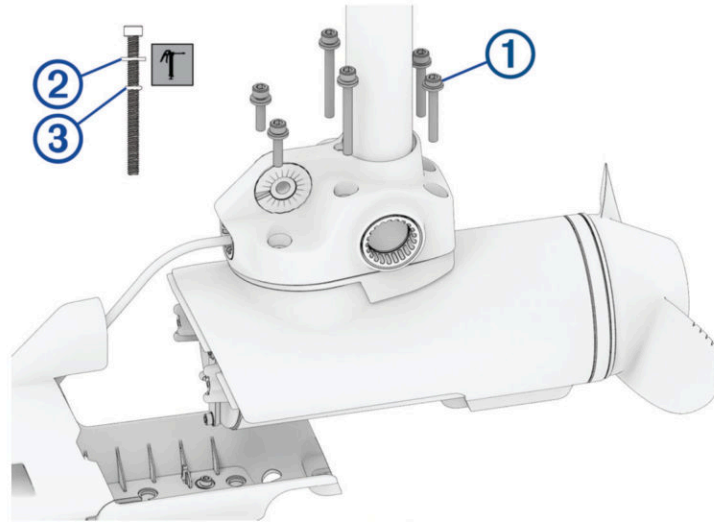

- 4 Using the grease packet included in the kit, apply grease to the 4.75 mm ($3/16$ in.) O-ring on each bolt. Avoid getting grease on the bolt threads.
- 5 Apply a medium-strength thread-locking compound (not included) such as LOCTITE® 243™ to the threads in the six threaded holes on the top of the propeller drive motor.

NOTICE

You must apply thread-locking compound in these holes to maintain a tight connection between the shaft base and the propeller drive motor. Failure to use thread-locking compound can lead to water ingress and damage to the motor.

- 6 Using a 5 mm hex bit or wrench, thread all six of the prepared bolts approximately halfway to make sure that the shaft base and the propeller drive motor are properly aligned and the gasket is in place.
- 7 With the shaft base and the propeller drive motor properly aligned, lightly tighten all six bolts by hand.
- 8 Using a torque wrench, tighten all six bolts to 4 N-m (3 lbf-ft).

Installing the Shaft in the Steering Servo Housing

⚠ CAUTION

This procedure is best performed with two people to prevent injury or damage to the trolling motor.

Insert the shaft into the bottom of the steering servo housing, and push it through, taking care not to damage the skog and transducer or snag the cables or connectors as you push it through.

TIP: To ease shaft installation, remove the shaft mini-tumbler and biasing bushing ([Removing the Shaft Mini-Tumbler and Biasing Bushing](#), page 39).

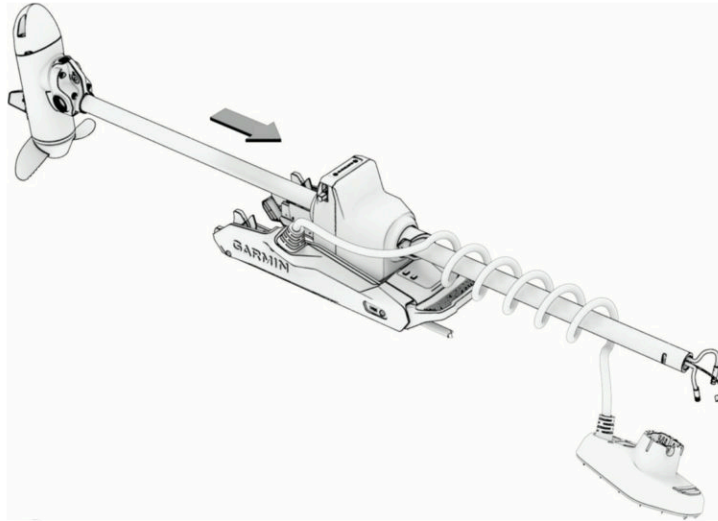

Connecting the Coil Cable Junction Box to the Mount Base

- 1 If you are replacing the coil cable, remove the coil cable from the shaft cap (*Removing the Coil Cable from the Shaft Cap, page 35*).
- 2 If necessary, install the replacement coil cable in the shaft cap (*Installing the Coil Cable in the Shaft Cap, page 62*).
- 3 Route the power cable and transducer cable (if present) through the mount base (*Routing the Power and Transducer Cables Through the Mount, page 55*).
- 4 Align the coil cable junction box with the holes on the mount base.
- 5 Using a 3mm hex bit or screwdriver, insert and tighten the three screws ① to secure the coil cable junction box to the mount base.

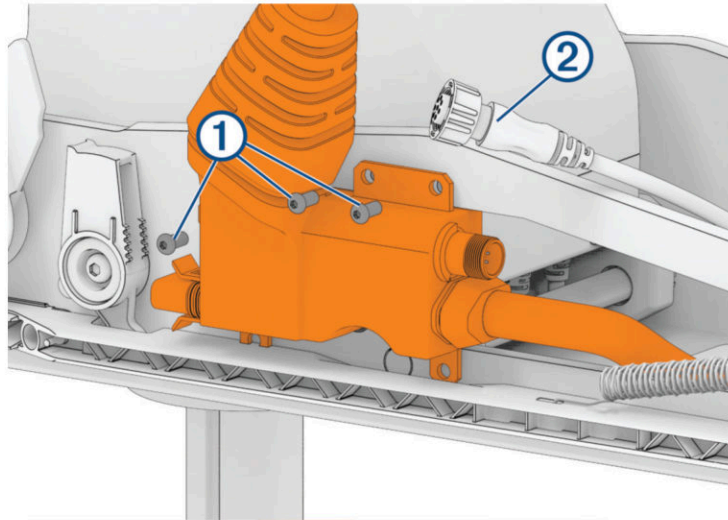

- 6 Apply dielectric grease to the data cable connector ②, and ensure the o-ring is in place.
- 7 Reconnect the data cable.

Installing the Shaft Cap

- 1 Ensure the rubber wedge ① and o-ring ② are in place on the shaft.

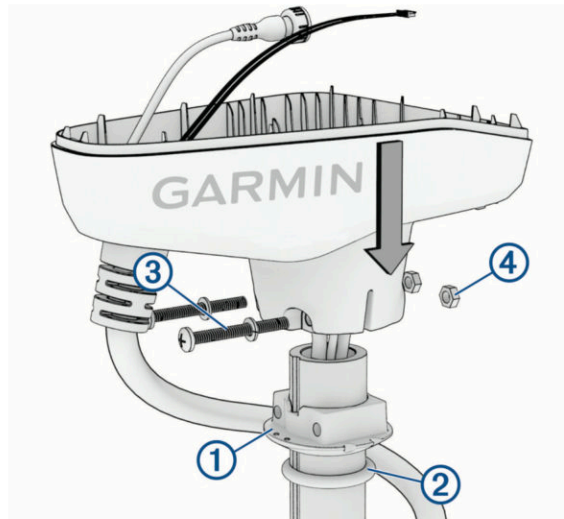

- 2 Using the coil count you recorded when you removed the shaft cap, wrap the coil cable around the shaft the appropriate number of times.
- 3 Pull the cables from the shaft completely through the shaft cap.
- 4 Place the shaft cap on the shaft, aligning the coil cable extending from the shaft cap with the groove on the shaft.
- 5 Using a #3 Phillips bit or screwdriver, secure the shaft cap to the shaft with the $\frac{1}{4}$ -20 bolts ③ and nuts ④ you removed earlier.

Installing the Coil Cable in the Shaft Cap

NOTICE

Before feeding the coil cable, ensure the coil cable has the same number of coils around the shaft as you recorded during removal. If the cable is wound too tight or too loose, the cable may bind and restrict the motion of the motor.

- 1 Feed the cables from the existing or replacement coil cable into the hole in the shaft cap.
- 2 Slide the coil cable bracket ① over the cable boot.



- 3 Secure the coil cable bracket to the shaft cap with the screws you removed earlier ②.

Connecting the Cables in the Shaft Cap

- 1 Add dielectric grease to the connectors of the power, GPS data, motor data cables, and transducer cable (if present).
- 2 Place the protective coverings on the power cables ①.

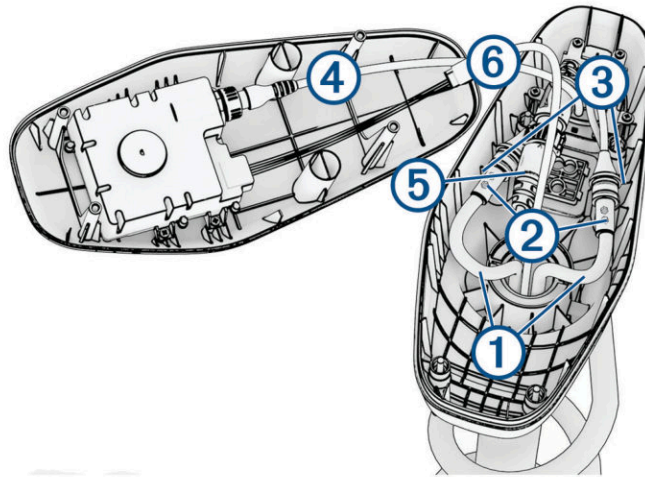

- 3 Reconnect the power cables and, using a 2.5 mm hex bit or wrench, tighten the set screws ②.
- 4 Slide the protective coverings over the power cable connections.
- 5 Secure the power cables to the shaft cap using zip ties at the locations you removed them when disconnecting the power wires ③.
- 6 Reconnect the GPS data ④ and transducer ⑤ cable, and tighten the collars.
- 7 Align both sections of the motor data cable connector ⑥ and press together to connect them.

Installing the Transducer Cable in the Shaft Cap

- 1 If previously removed, feed the transducer cable ① completely through the square hole in the shaft cap.



- 2 Install the grommet ② on the transducer cable.
The grommet is split on one side to make it easy to install on the cable.
- 3 Push from the outside to secure the square grommet in the shaft cap.
- 4 Route the transducer cable alongside the coil cable, using electrical tape to hold the cables together.
- 5 Route the LiveScope transducer cable to the sonar module or to the transducer extension cable and connect it.

Installing the Antenna Box

- 1 Position the antenna box ① in the upper shaft cap housing.

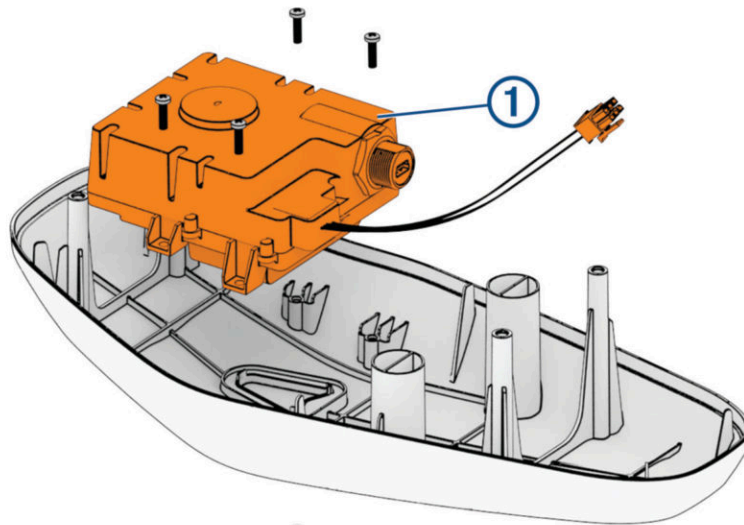

- 2 Using a # 1 Phillips bit or screwdriver, install the four screws that secure the antenna box to the upper shaft cap housing.

Connecting the Antenna Box Cables

- 1 Apply dielectric grease to the GPS data connector ①.
Ensure the o-ring remains in place inside the connector.

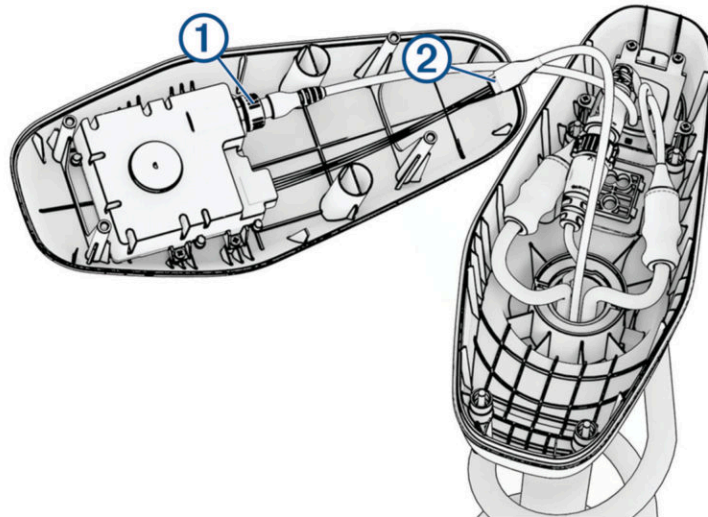

- 2 Connect the GPS connector and tighten the collar.
- 3 Apply dielectric grease to the motor data cable connector ②.
- 4 Press the two halves of the motor data cable connector together until they latch.

NOTICE

To avoid damaging the cable, push only on the connector body. Do not push on the wire itself.

Closing the Shaft Cap

- 1 Place the lid on the shaft cap.

NOTICE

Ensure the cables are routed away from pinch points before securing the shaft cap lid to avoid damaging the cables.

- 2 Using a #2 Phillips bit or screwdriver, install the four screws you removed previously to secure the lid of the shaft cap.



Installing the Latch Pusher Linkage on the Latch Pedal

Before you install the latch pusher linkage, you must install the latch pedal (*Installing the Latch Pedal*, page 69).

- Lift the latch pedal straight up ①, and place the latch pusher linkages on the latch pedal ②.



Installing the Cradle Hardware

- 1 Apply marine grease to the cradle bushings ①.

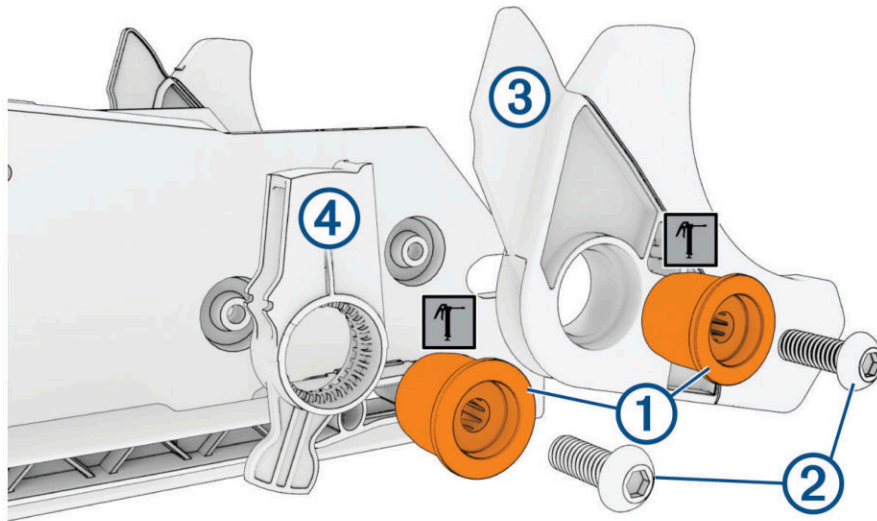

- 2 Using a 4 mm hex bit or wrench, install the screws ②, bushings, cradle catch ③, and cradle hook ④.
- 3 With the hook on the spring facing toward the mount, insert the cradle tension spring ⑤ into the cradle catch and attach the loop on the cradle tension spring on the hook inside the cradle catch ⑥.

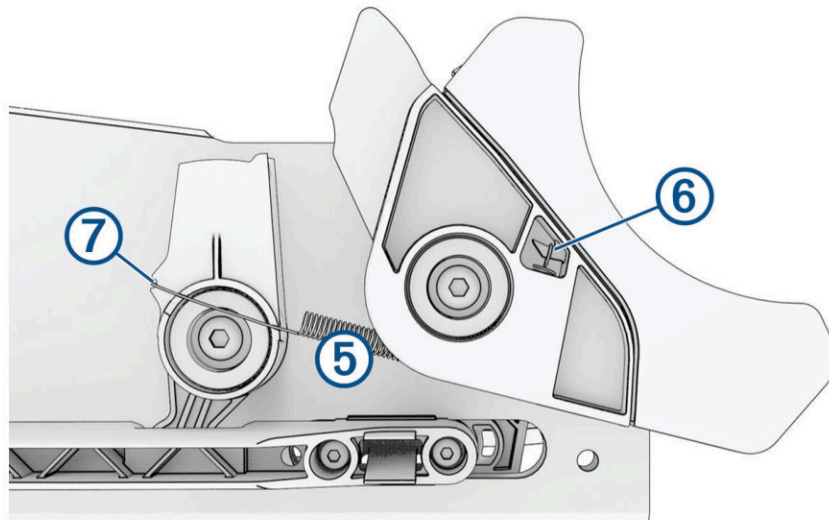

- 4 Secure the hook on the cradle tension spring to the notch on the cradle hook ⑦.
- 5 Repeat this procedure on the opposite side.
- 6 Test the cradle function.

Installing the Latch Pushers

Before installing the latch pushers, you must install the latch pusher linkage (*Installing the Latch Pusher Linkage on the Latch Pedal, page 65*).

- 1 Snap the latch pusher ① onto the pusher linkage ②.

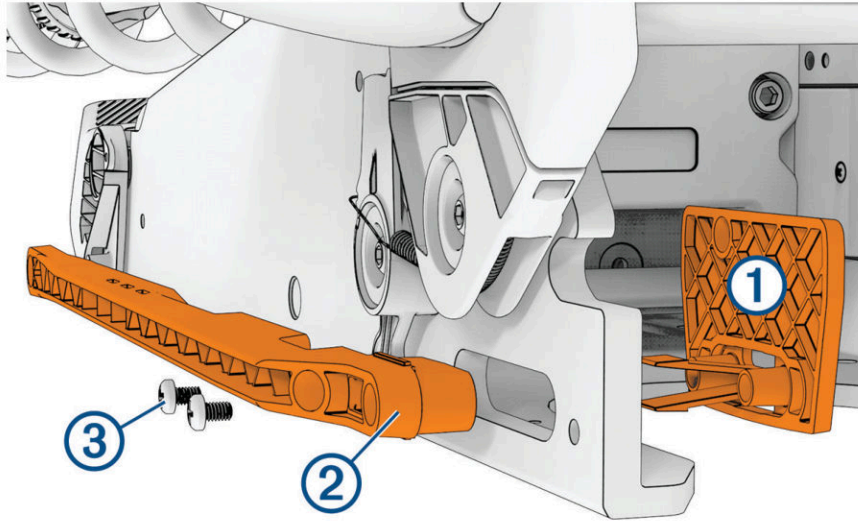

- 2 Using a #2 Phillips bit or screwdriver, secure the pusher linkage to the latch pusher using the two screws ③.
- 3 Repeat this procedure on the opposite side.

Installing the Latch Tension Springs

Before you install the latch tension springs, you must install the latch pusher linkage (*Installing the Latch Pusher Linkage on the Latch Pedal, page 65*).

- Carefully hook the latch tension springs ① onto the latch pedal ② and the pusher linkage ③.

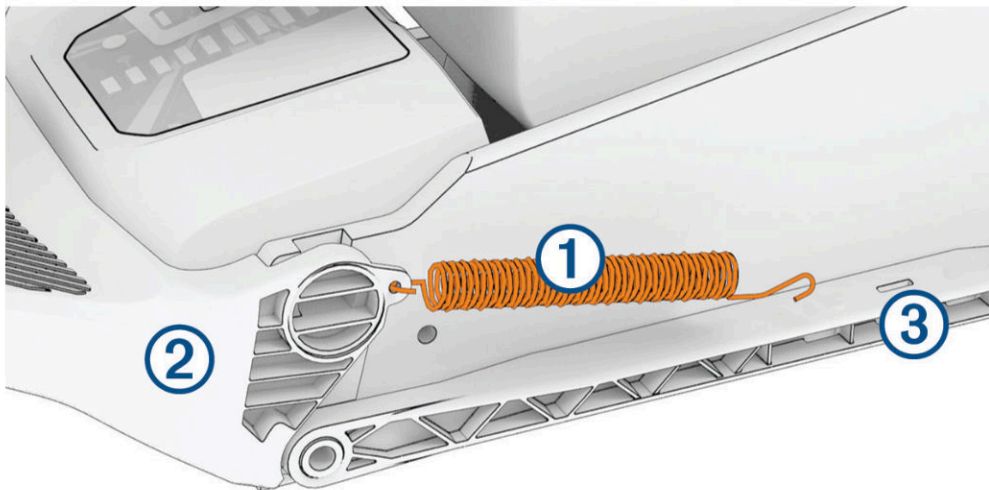

Installing the Cradle Tension Springs

- 1 Attach the loop on the cradle tension spring ① on the hook ② inside the cradle catch ③.

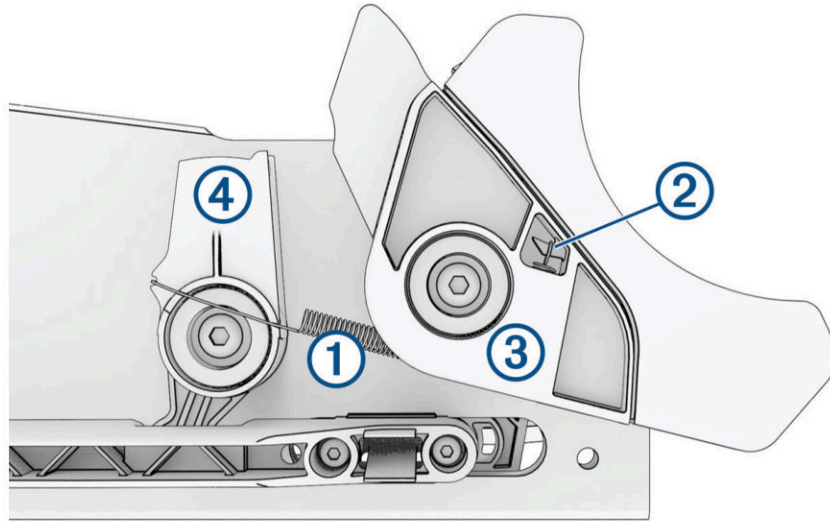

- 2 Secure the hook on the cradle tension spring to the notch on the cradle hook ④.

Installing the Mount Shrouds

- 1 Lift the cradle catch so it will not obstruct the mount shroud installation.
- 2 Using a 4 mm hex bit or wrench, install the screws ① that secure the mount shroud ② to the mount base.

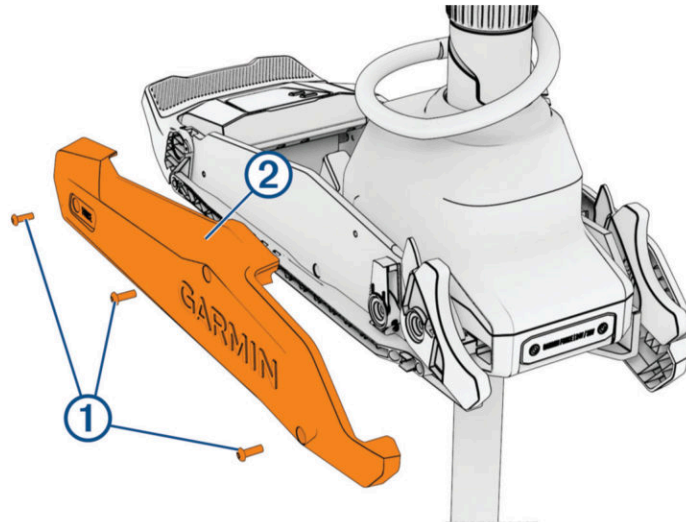

- 3 Repeat this step to install the mount shroud on the opposite side.

Installing the Latch Pedal

- 1 Apply marine grease to the latch pedal pivot points and the latch pedal notches on the mount base.



- 2 Align the latch pedal pivot points with the notches in the mount base, and slide the latch pedal into position.
- 3 Rotate the latch pedal down.

Installing the Skeg

Using a 4 mm hex bit or wrench, secure the skeg to the propeller drive motor using the four screws you removed earlier, ensuring the longer end of the skeg faces the propeller side.

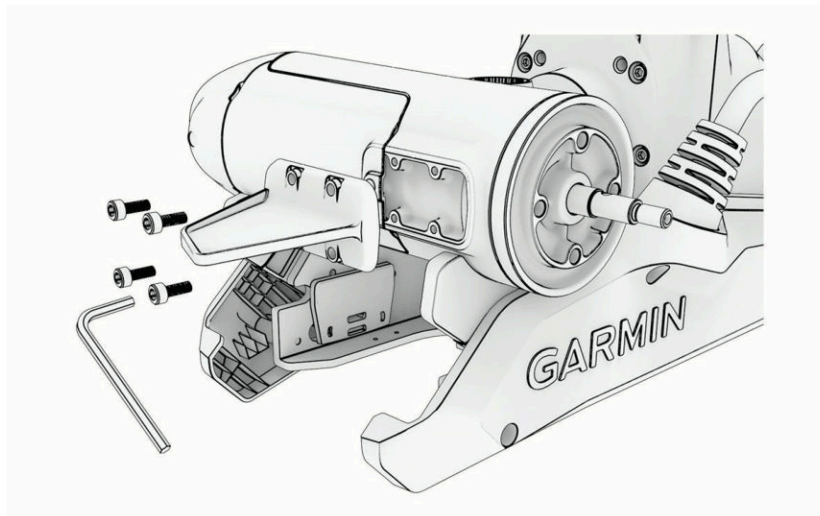

Installing the Propeller

- 1 Insert the pin ① through the propeller motor shaft ②.

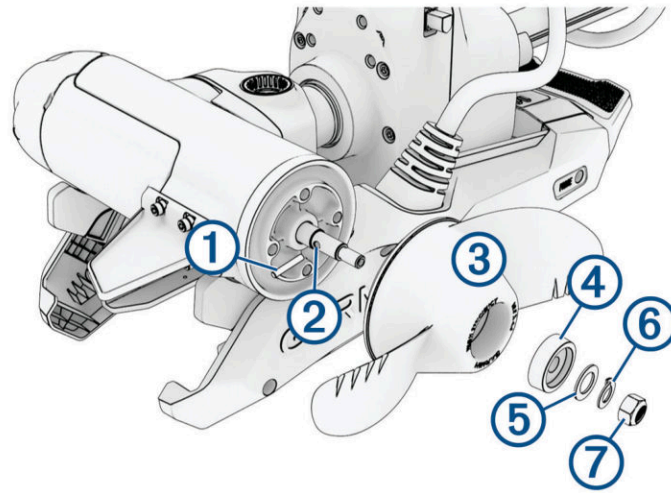

- 2 If necessary, rotate the motor shaft to orient the pin horizontally so it is less likely to fall out during installation.
- 3 Align the channel on the inside of the propeller ③ with the pin, and slide the propeller onto the motor shaft.
- 4 Place the anode ④, washer ⑤, lock washer ⑥, and nut ⑦ onto the end of the motor shaft.
- 5 Using a $\frac{9}{16}$ in. (14 mm) socket, tighten the lock nut to 8.13 N-m (6 lbf-ft) to secure the propeller.

Installing the Shaft Carrier

Place the shaft carrier into the lower steering servo housing.

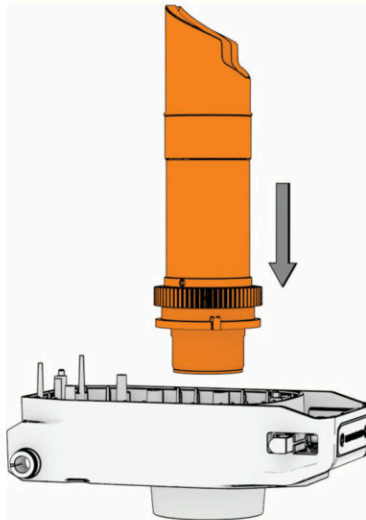

Installing the Steering Motor Module

- 1 Carefully place the steering motor module in the steering servo housing.
- 2 Place the four rubber washers ① and four steel washers ② over the isolation spacer bushings.

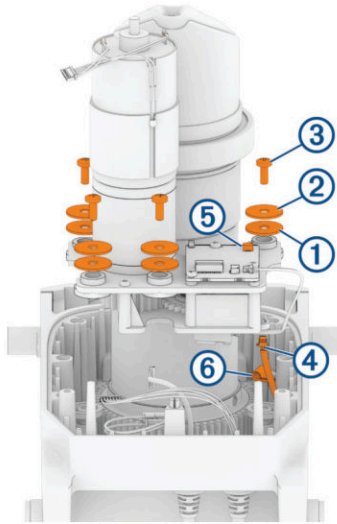

- 3 Using a #2 Phillips screwdriver, install the four screws ③ to secure the steering motor module.
- 4 Connect the latch sensor cable ④ to the steering motor module PCB ⑤, ensuring the cable is routed through the P-clip ⑥.

Installing the Steering Servo PCB

NOTICE

This procedure exposes the main PCB. Always follow electrostatic discharge (ESD) prevention procedures when opening the steering servo housing. ESD can damage your PCB, and prevent your motor from functioning properly.

Place the PCB into the steering servo housing.

- 2 Using a #2 Phillips bit or screwdriver, secure the PCB to the steering servo housing using the two screws ①.

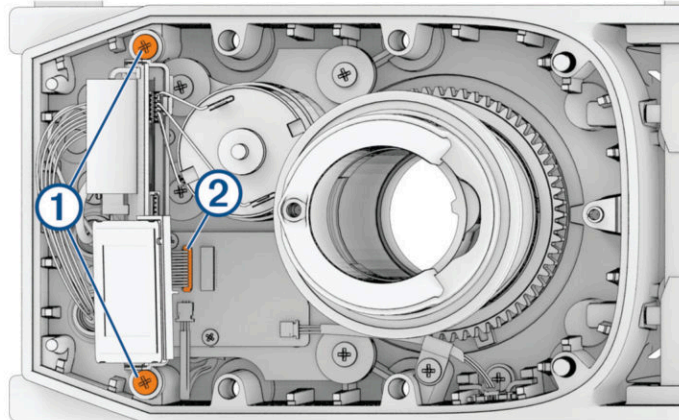

- 3 Connect the position sensor connector ②.

- 4 Connect the three steering servo cable connectors ③ and the motor connector ④.

NOTICE

The cables and connectors are very fragile. Use extreme care when disconnecting and reconnecting these cables to the PCB to avoid possible damage to the cables and connectors. Only pull and push on the connectors, not the cables.

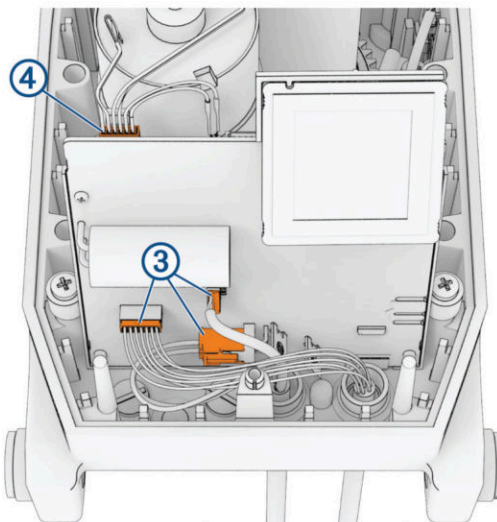

NOTICE

Ensure the steering servo wires are tucked behind the bottom post to prevent damage to the wires when closing the steering servo housing.

Closing the Steering Servo Housing

NOTICE

Ensure the steering servo wires are tucked behind the bottom post to prevent damage to the wires when closing the steering servo housing.

- 1 Set the bottom of the steering servo housing on a table or workbench with the shaft carrier and servo motor pointing up.
- 2 Apply a light layer of synthetic or marine grade, general-purpose grease to the black rubber seal ① around the shaft-carrier opening in the steering servo housing.

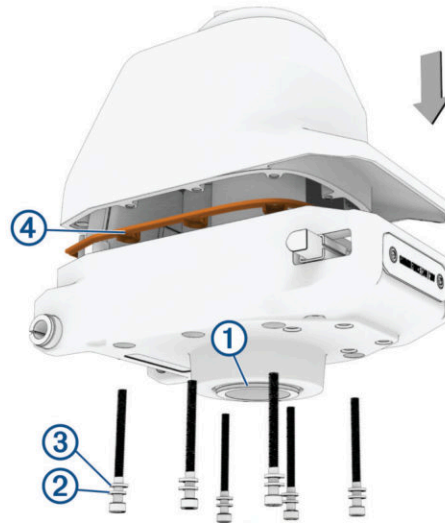

- 3 Install the six metal washers ② on the six screws.
- 4 Install the six nylon washers ③ on the six screws.
- 5 Make sure the gasket ④ is installed in the groove around the perimeter of the lower steering servo housing.
- 6 Place the top of the steering servo housing over the shaft carrier, and lower it onto the top of the steering servo housing.
NOTE: You may need to start by connecting the back parts of the housing first, and rotate the front of the housing into place.
- 7 Holding the two steering servo housing halves together, carefully place the steering servo on its side, and install one or two of the screws with a 5 mm hex bit or wrench to hold the parts together.
- 8 Install the remaining screws.
- 9 Tighten all of the screws to 4.9 N-m (3.6 lbf-ft).

