

PANEL CUT PROFILE

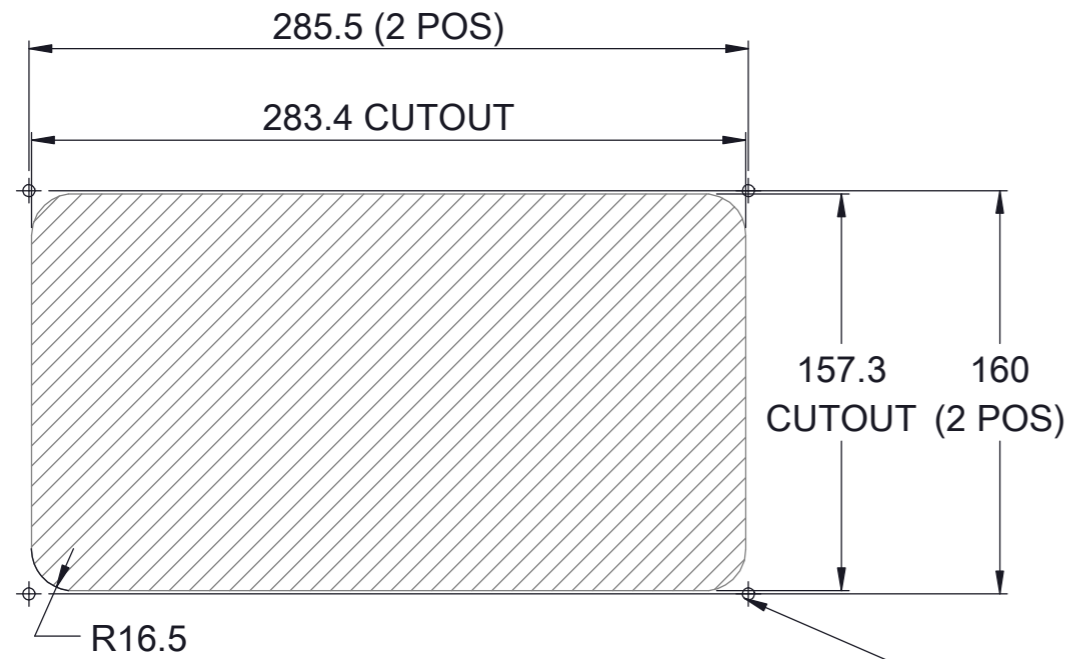

DRILL HOLE SUITABLE FOR FIXING SCREWS X 4 POS

NOTES:

- 1) FOR INFORMATION ON CONNECTIONS AND PRODUCT SPECIFICATIONS, PLEASE REFER TO HANDBOOK, PRODUCT SUPPORT AND WORKSHOP MANUALS.
- 2) FOR ANY DIMENSIONAL INFORMATION NOT INCLUDED PLEASE CONTACT YOUR SALES REPRESENTATIVE.
- 3) DIMENSIONS SHOWN ARE ACTUAL PRODUCT SIZE AND DO NOT INCLUDE ANY CLEARANCE DATA.



201.4  
MINIMUM  
CLEARANCE

FOR 90° CABLE  
THE MINIMUM  
CLEARANCE  
WILL BE REDUCED

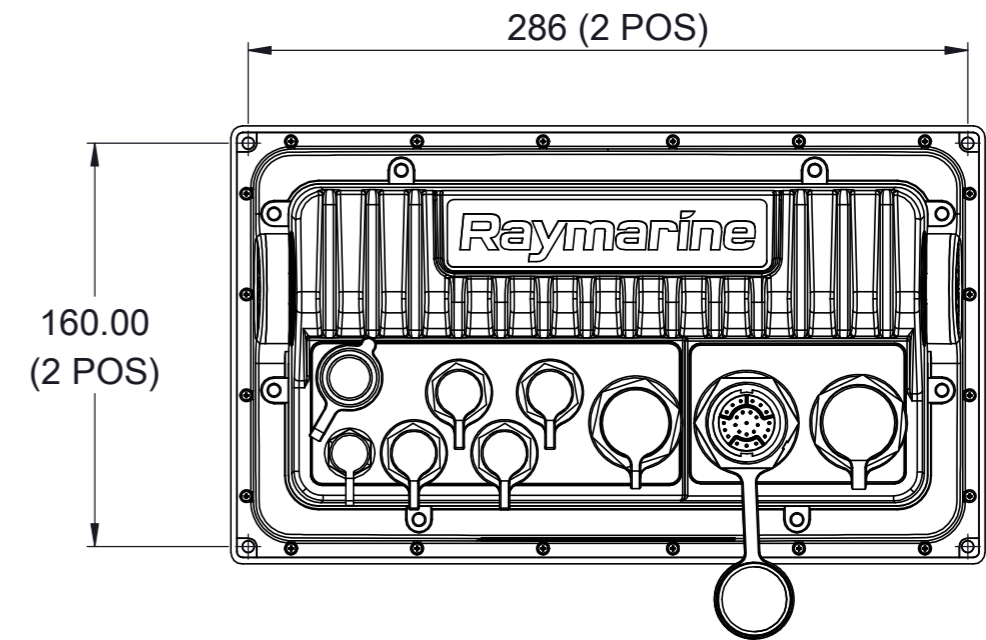
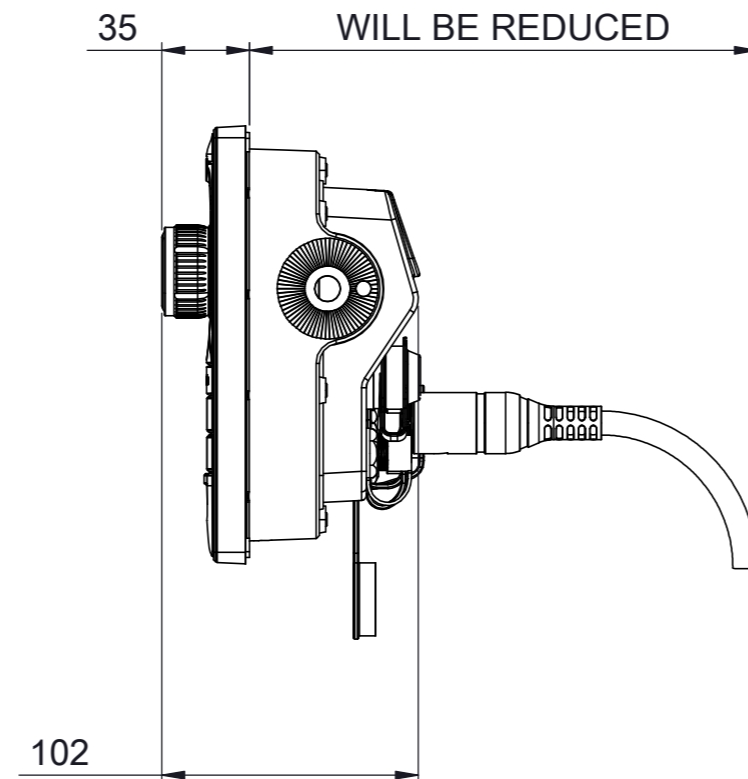
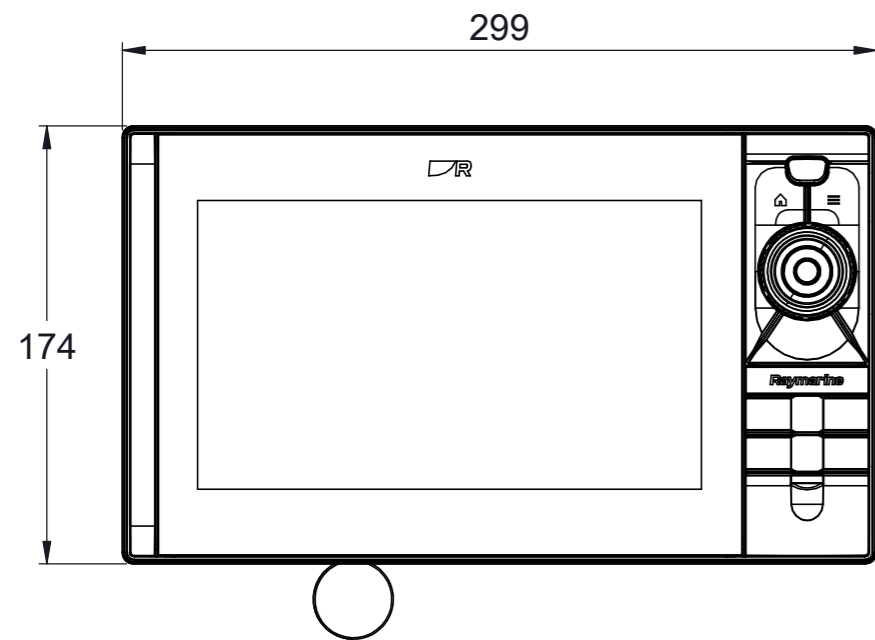

**Raymarine**

© 2019 RAYMARINE LTD  
Company Confidential

THE INFORMATION CONTAINED HEREIN SHALL NOT BE REPRODUCED WITHOUT THE PRIOR WRITTEN PERMISSION OF RAYMARINE LTD

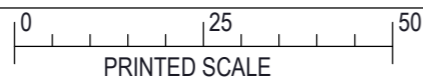

DRAWN TO BS308

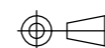

DO NOT SCALE - IF IN DOUBT ASK

DRN: MA  
DIMENSIONS IN MM

DATE: 2026-04-22  
SCALE: 1:3

TITLE  
D\_ENDEAVOUR9\_SM

DRAWING No.  
D\_ENDEAVOUR9\_RM\_TM\_SM