

8 7 6 5 4 3 2 1



NOTES:

- 1) FOR INFORMATION ON CONNECTIONS AND PRODUCT SPECIFICATIONS, PLEASE REFER TO HANDBOOK, PRODUCT SUPPORT AND WORKSHOP MANUALS.
- 2) FOR ANY DIMENSIONAL INFORMATION NOT INCLUDED PLEASE CONTACT YOUR SALES REPRESENTATIVE.
- 3) DIMENSIONS SHOWN ARE ACTUAL PRODUCT SIZE AND DO NOT INCLUDE ANY CLEARANCE DATA.

208.53
MINIMUM
CLEARANCE

FOR 90° CABLE
THE MINIMUM
CLEARANCE

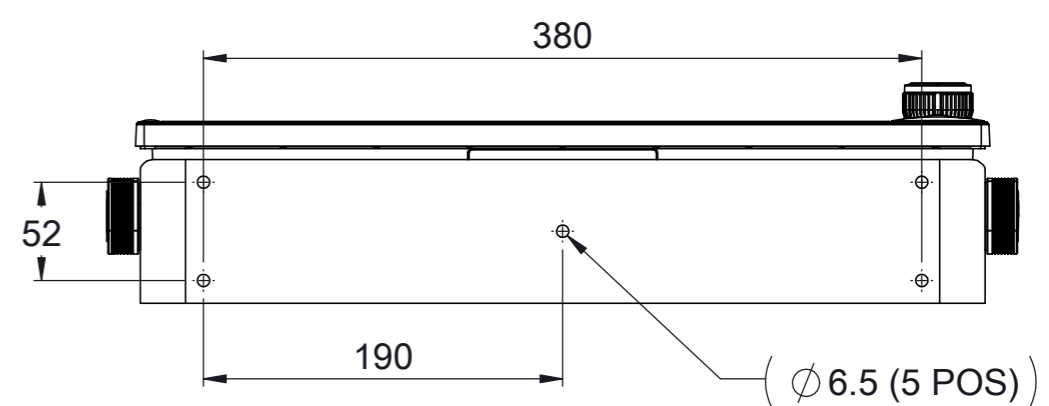
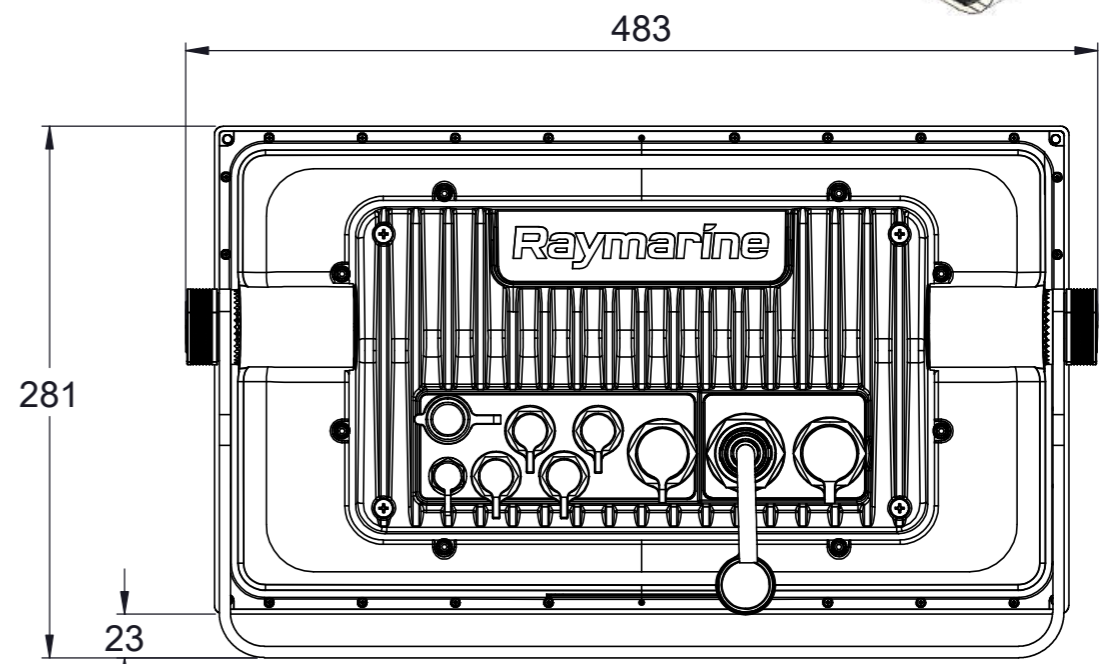
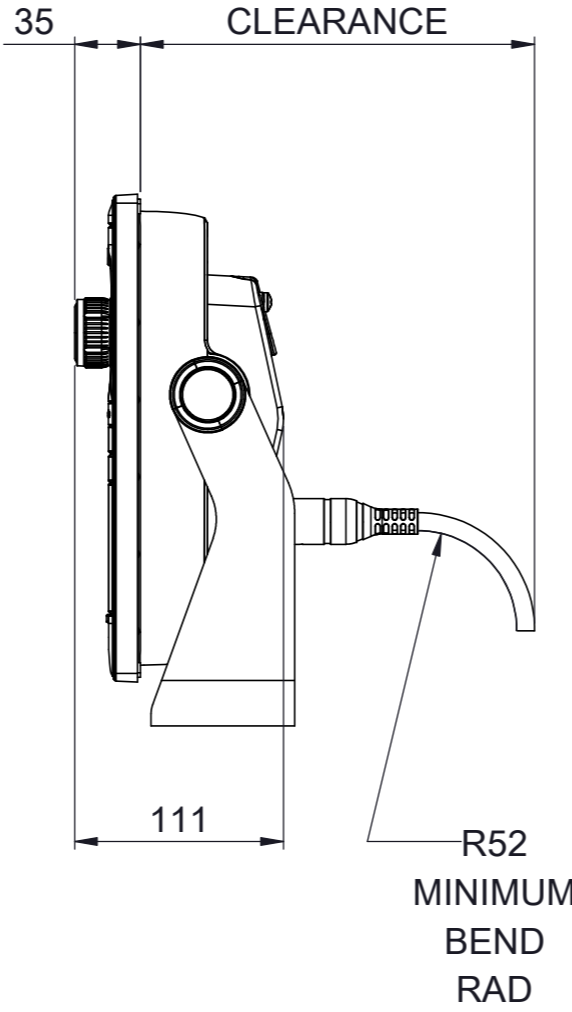
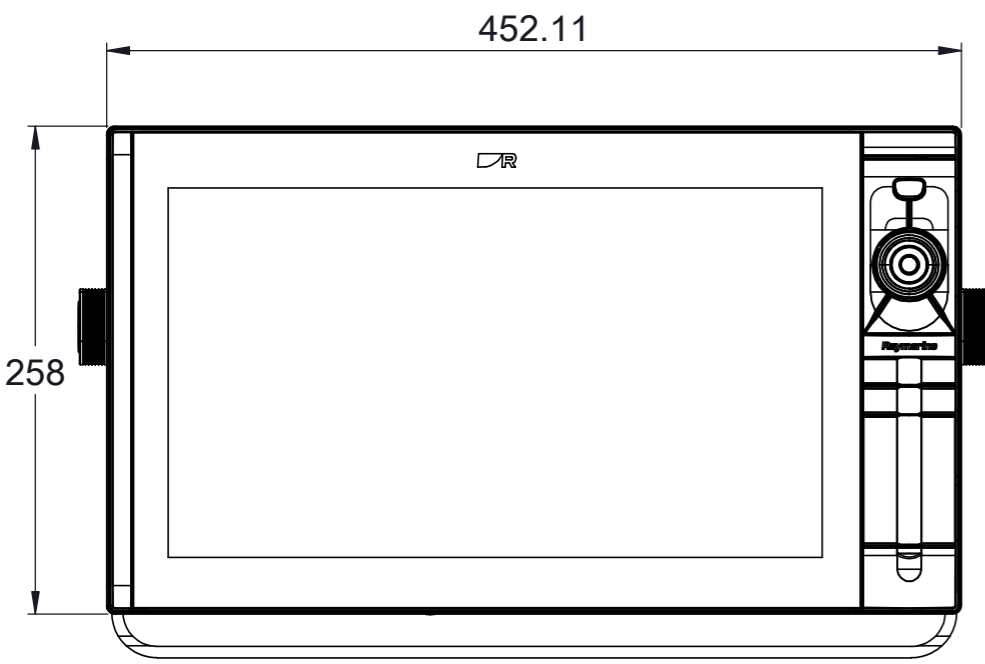

Raymarine

© 2019 RAYMARINE LTD
Company Confidential

THE INFORMATION CONTAINED HEREIN SHALL NOT BE REPRODUCED WITHOUT THE PRIOR WRITTEN PERMISSION OF RAYMARINE LTD

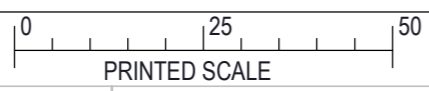

DRAWN TO BS308

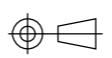

DO NOT SCALE - IF IN DOUBT ASK

DRN: MSA
DIMENSIONS IN MM

DATE:
SCALE: 1:4

TITLE
D_ENDEAVOUR16_TM
DRAWING No.
D_ENDEAVOUR16_SM_TM

8 7 6 5 4 3 2 1