

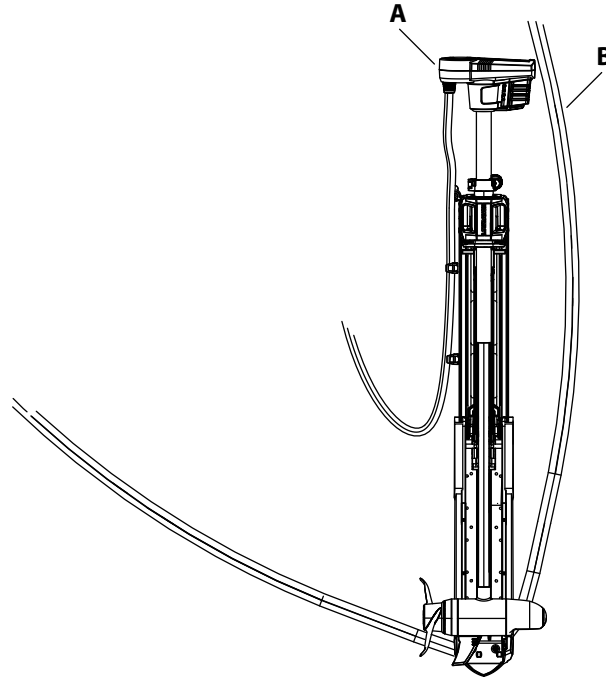

Ghost trolling motor 60"

Installation

Ensure that the trolling motor head (**A**) does not protrude outside of the gunwale (**B**) of the boat when in the stowed position. Check the overhang when the motor is fully stowed in the correct position before securing the mount to the boat.



Stowing

When the trolling motor is stowed, the lower unit (**A**) must rest on the wear bearings or on top of the kicker (**B**). You may need to loosen the depth adjustment knob and slide the motor up so that it rests properly on the mount when stowed. Remember to tighten the knob before stowing the motor.

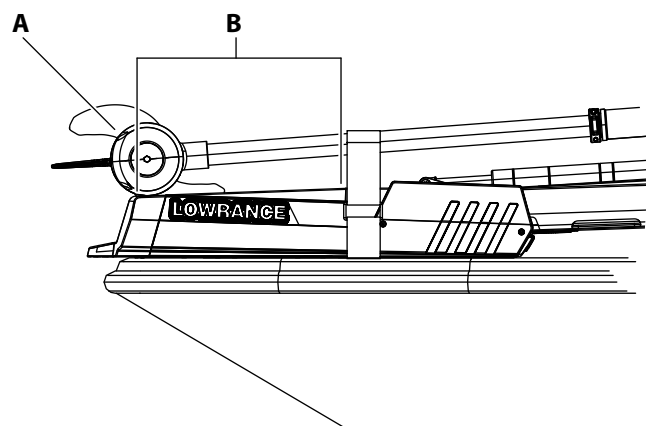

Troubleshooting the TMR-1 remote

If you are unable to pair the TMR-1 to the trolling motor, perform a trolling motor factory reset. When the reset is complete, try to pair the TMR-1 with the trolling motor.

After performing the factory reset, you will need to re-calibrate the bow offset, and re-configure the foot pedal keys and battery voltage.

For instructions, refer to the installation manual for your trolling motor and remote.