

**LOWRANCE®**

# Ghost® Series

Operator manual

English



[www.lowrance.com](http://www.lowrance.com)



## Copyright

© 2025 Navico Group. All Rights Reserved. Navico Group is a division of Brunswick Corporation.

## Trademarks

®Reg. U.S. Pat. & Tm. Off, and ™ common law marks.

Visit [www.navico.com/intellectual-property](http://www.navico.com/intellectual-property) to review the global trademark rights and accreditations for Navico Group and other entities.

- Navico® is a trademark of Navico Group
- Lowrance® is a trademark of Navico Group
- Ghost® is a trademark of Navico Group
- Active Imaging™ is a trademark of Navico Group
- FlipSwitch™ is a trademark of Navico Group
- Bluetooth® is a trademark of Bluetooth SIG, Inc
- NMEA® and NMEA 2000® are trademarks of the National Marine Electronics Association
- QR code® is a trademark of Denso Wave Incorporated
- SD® and microSD® are trademarks of SD-3C, LLC
- Teflon® is a trademark of the Chemours Company FC, LLC

## Safety, disclaimer, and compliance

This product's safety, disclaimer, and compliance statements are supplied as a separate document.

## More information

Document version: 008

For the latest version of this document in supported languages and other related documentation, visit:

[www.lowrance.com/downloads/ghost](http://www.lowrance.com/downloads/ghost).



# CONTENTS

---

<b>6</b>	<b>Product overview</b>
<b>7</b>	<b>Foot pedal</b>
<b>7</b>	<b>Safe operation with the trolling motor</b>
<b>8</b>	<b>Deploy and stow the trolling motor</b>
8	Deploy
9	Stow
<b>10</b>	<b>Adjust the trolling motor</b>
10	Depth adjustment
11	Adjust the FlipSwitch
13	Adjust the braided stainless steel pull cable length
<b>14</b>	<b>Operation</b>
14	Power the trolling motor ON or OFF
14	Check the battery capacity
15	Steer with the foot pedal
15	Activate the propeller
16	Adjust the speed
16	Select a mode or action
<b>19</b>	<b>Service and maintenance</b>
19	General maintenance
19	Maintenance schedule
21	Propeller replacement
22	Configuration mode
22	Enter or exit configuration mode
<b>23</b>	<b>Bluetooth® pairing</b>
<b>23</b>	<b>Factory reset</b>
<b>23</b>	<b>Lowrance App</b>
<b>24</b>	<b>Software updates</b>
24	Update from MFD
24	Update from the app
24	Force a software upgrade
<b>25</b>	<b>Troubleshooting</b>
26	Direction indicator LED and audible feedback
27	Error codes and troubleshooting
28	Foot pedal LED indicators
29	Serial number

# PRODUCT OVERVIEW

The Lowrance Ghost Series includes the Ghost freshwater trolling motor, available with shaft lengths 47, 52, or 60 inches, and Ghost X, the next generation Ghost trolling motor with upgraded lower unit and steering indicator (shaft length: 47 inches).

**⚠ WARNING:** These products are intended to be used in freshwater only. A sacrificial anode, sold separately, is required for use in brackish water. Use of the product in brackish water (without the anode) or saltwater will void the warranty.

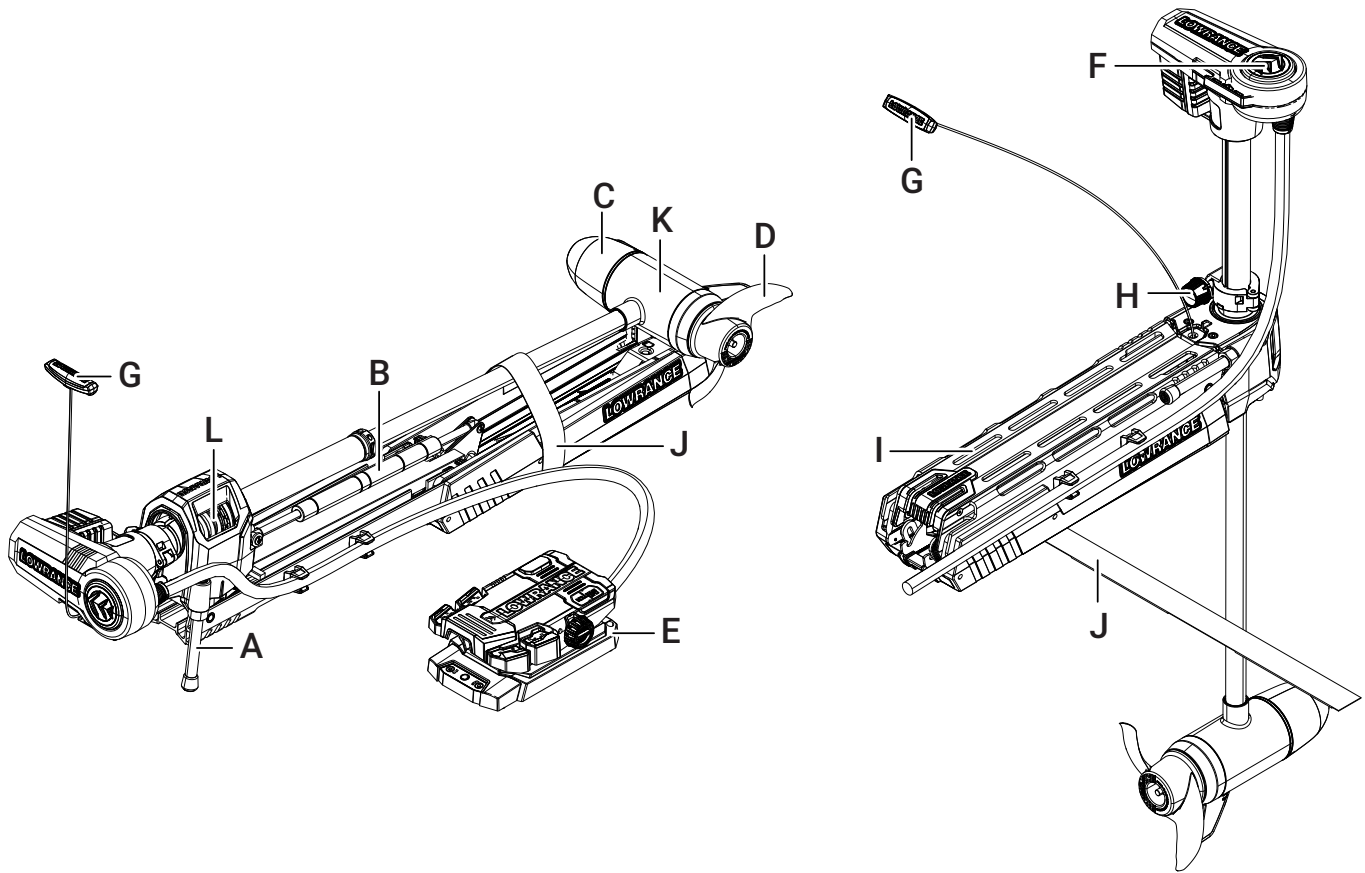

Stowed position

Deployed position

- A Stabilizer
- B Stow and deploy assist spring
- C Nose cone\*
- D Propeller
- E Foot pedal
- F Direction indicator
- G Braided stainless steel pull cable and handle
- H Depth adjustment knob
- I Motor mount
- J Stow strap
- K Lower unit
- L 360 breakaway

	Ghost 47", 52", and 60" models	Ghost X
*Transducer	HDI nose cone; pre-installed	Active Imaging 3-in-1 nose cone

# FOOT PEDAL

---

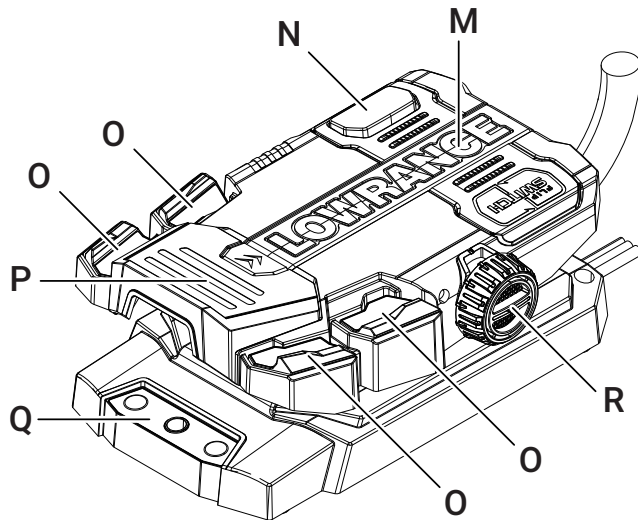

Foot pedal

- M** Toe end
- N** Momentary switch
- O** Mode and action keys
- P** Heel end
- Q** Power key and battery capacity indicator
- R** Speed adjustment knob

## SAFE OPERATION WITH THE TROLLING MOTOR

---

Do not use automatic steering when:

- In heavy traffic areas or in narrow waters
- In poor visibility or extreme sea conditions
- In areas where use of an autopilot is prohibited by law

When using a trolling motor:

- ⚠ Do not place any magnetic material or equipment near the heading sensor used by the trolling motor system
- ⚠ Verify at regular intervals the course and position of the vessel
- ⚠ Do not run the propeller out of the water. Doing so may cause serious injuries.
- ⚠ Disconnect power when the motor is being stored, transported or not in use for extended periods of time.
- ⚠ Always install the stow strap while the motor is stowed for transportation.
- ⚠ Always disconnect motor from the batteries before cleaning or checking the propeller.
- ⚠ Do not attempt to disassemble the 360 breakaway.
- ⚠ Keep fingers clear from moving parts when stowing or deploying the trolling motor.

# DEPLOY AND STOW THE TROLLING MOTOR

---

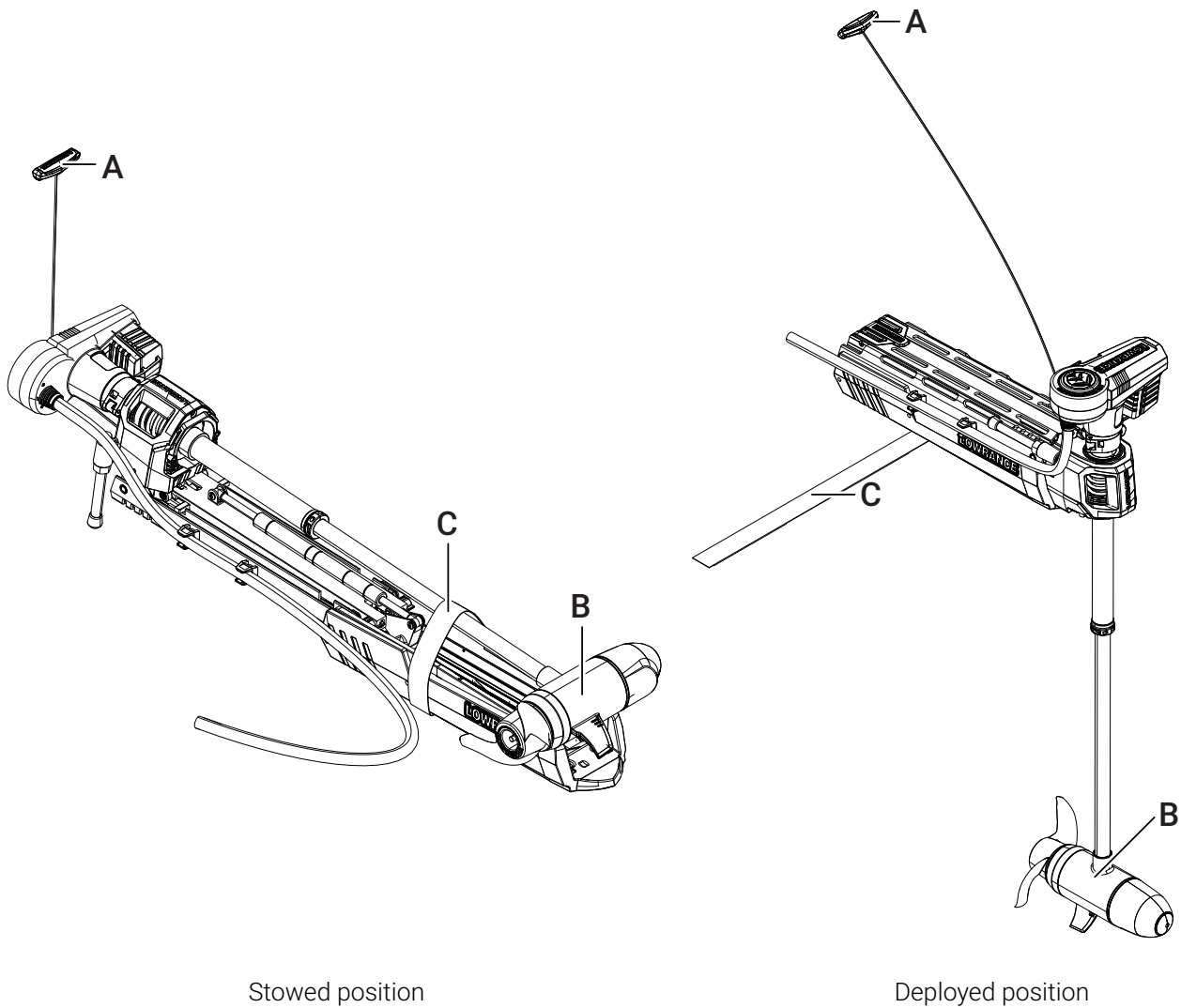

Stowed position

Deployed position

## Deploy

- 1 Release the stow strap (C) and pull the braided stainless steel pull cable by its handle (A) to unlatch the trolling motor from the stowed position.
- 2 Lift the trolling motor from the stowed position and tilt it down until it is locked in the deployed position. If the trolling motor is turned ON, the lower unit will position itself according to the foot pedal position. If the trolling motor is turned OFF, the lower unit will be deactivated until the trolling motor is turned ON and the foot pedal operated.
- 3 Make sure that the trolling motor is fully deployed and latched in the deployed position.

## Stow

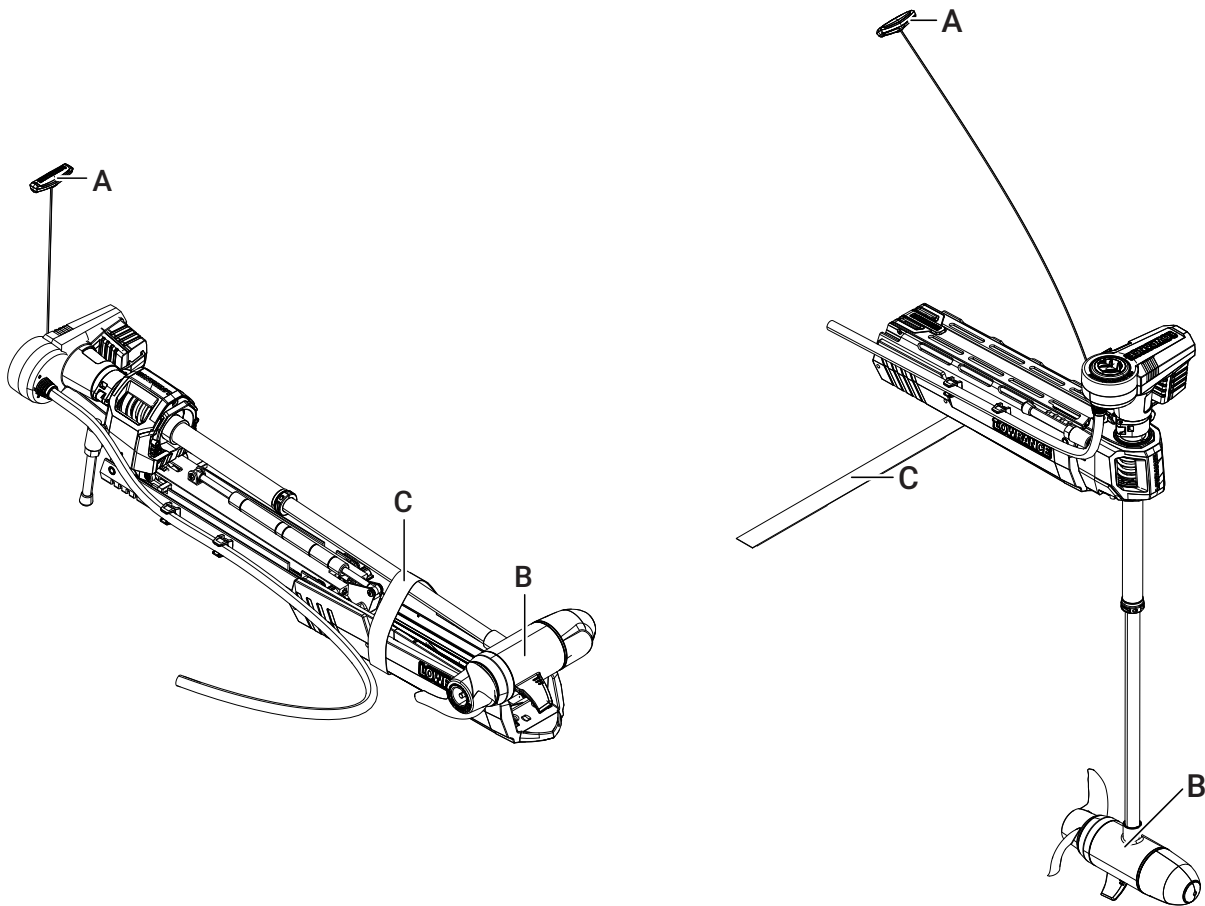

→ **Note:** The trolling motor should be ON while being stowed. This ensures the lower unit adjusts to the correct stowing angle.

- 1 Pull the braided stainless steel pull cable and handle (A) to unlatch the trolling motor from the deployed position.
- 2 Lift the pull cable up and backward to slowly lift the trolling motor into the stowed position.
- 3 Tilt the trolling motor to the stow position. The lower unit (B) will automatically adjust to the proper stowing angle.
- 4 If necessary, push the trolling motor down against the deck of the boat until it locks in the stow position.
- 5 Attach the stow strap (C).

→ **Note:** To avoid damage to the vessel, use the stow strap whenever the vessel is under power from another engine (including an outboard motor).

→ **Note:** Ensure that when stowed, the lower unit of the trolling motor (B) rests on the wear bearings or on top of the kicker (D, below). If this is not the case, before stowing the motor each time you may need to loosen the depth adjustment knob and slide the motor up, to prepare it to rest on the mount when stowed. Remember to retighten the knob before stowing the motor.

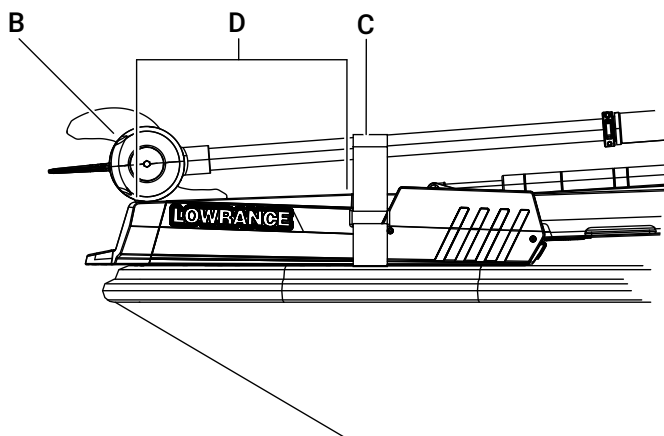

# ADJUST THE TROLLING MOTOR

---

## Depth adjustment

- 1 Loosen the depth adjustment knob (A).
- 2 Raise or lower the propulsion motor unit to the desired level.  
The motor unit should be at least 300 mm (12 in) below the surface of the water.
- 3 Tighten the depth adjustment knob (A).

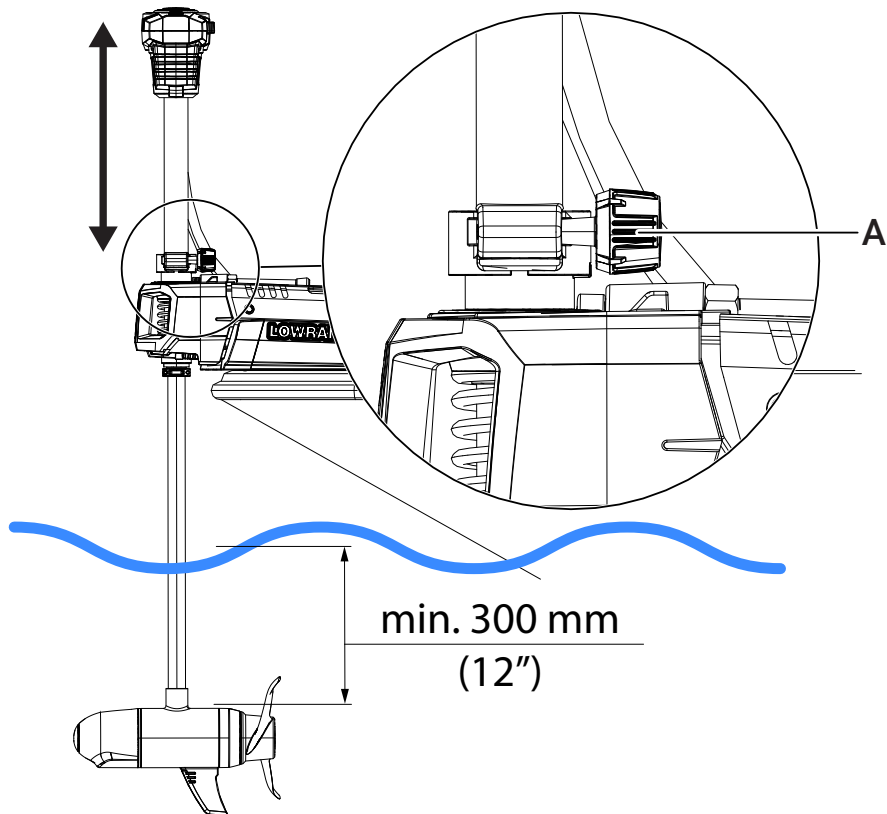

## Adjust the FlipSwitch

The FlipSwitch allows you to move the momentary switch (propeller ON switch) from the left side to the right side of the foot pedal.

### Tools required

- 1x Phillips screwdriver #2

### Procedure to move the FlipSwitch

1 Remove the lock screw (A) that secures the cover plate (B). The underside (heel end) of the foot pedal is shown.

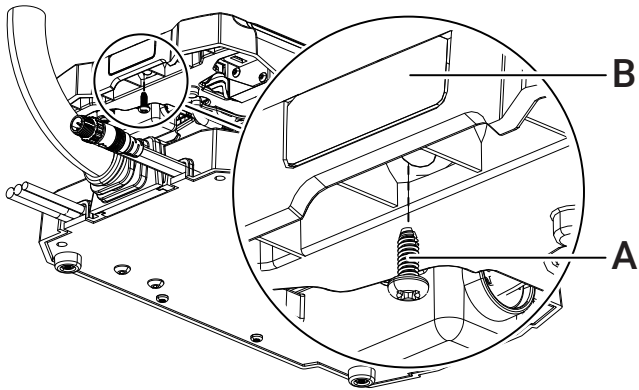

2 Press the locking tab (C) upwards and slide the cover plate (B) forward until it is free.

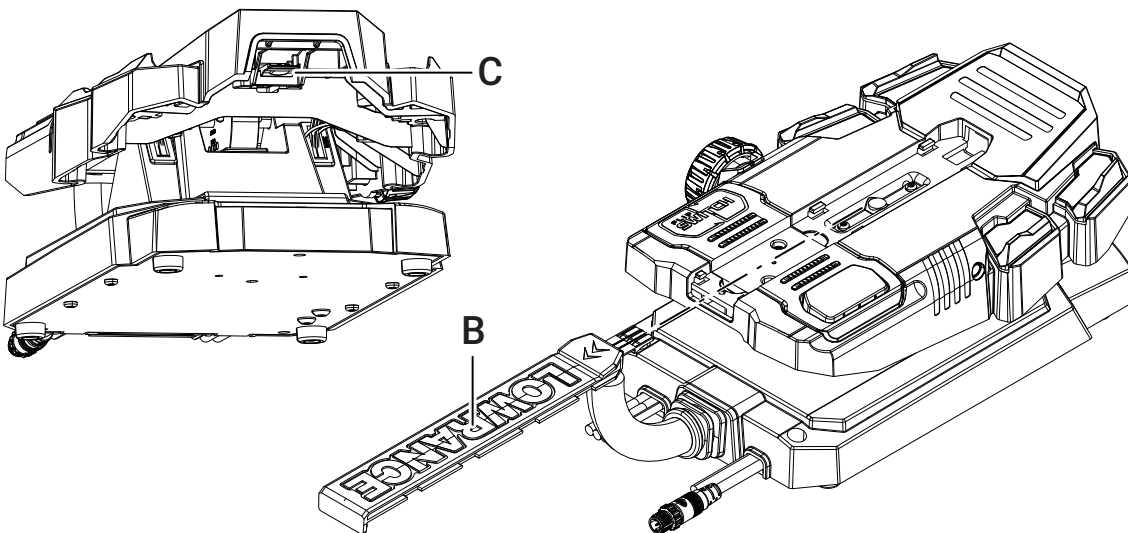

3 Remove the screws (D) that secure the FlipSwitch assembly.

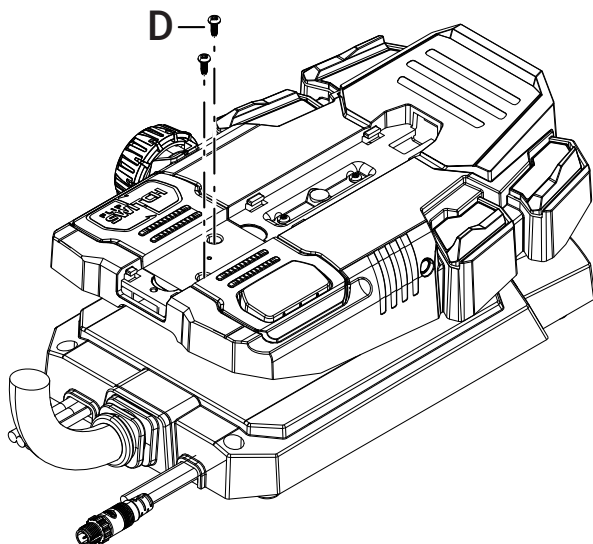

- 4 Turn the FlipSwitch assembly (E) 180° and fasten the screws (D) that secure the FlipSwitch assembly.

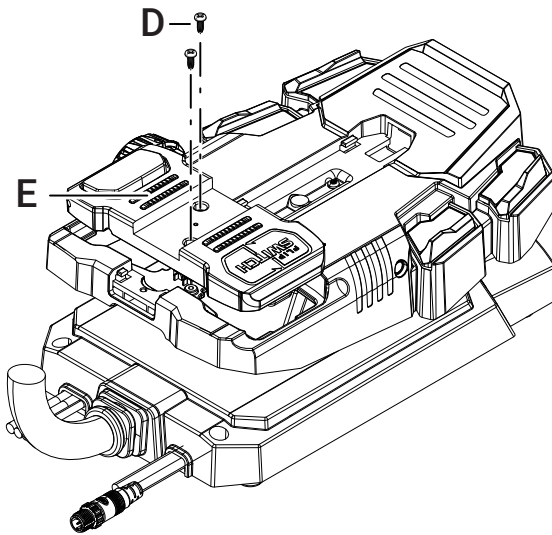

- 5 Slide the cover plate (B) back in place and fasten the lock screw (A).

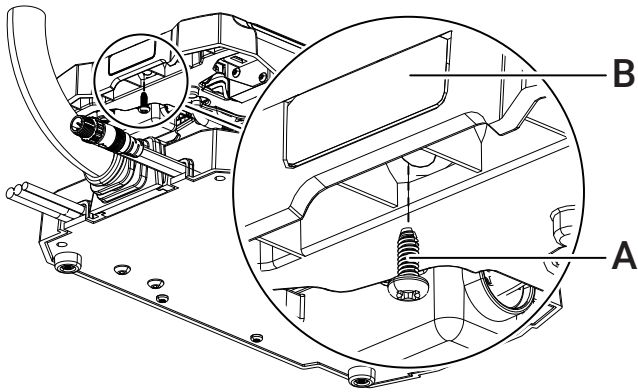

## Adjust the braided stainless steel pull cable length

### Tools required

- 2x small flathead screwdrivers
- ¼" wrench/socket (or adjustable wrench)
- 1x side-cutting pliers

### Procedure

- 1 Use two small flathead screwdrivers to apply pressure to both sides (**B** and **C**) of the locking tabs (**A**) to remove the handle top cover.

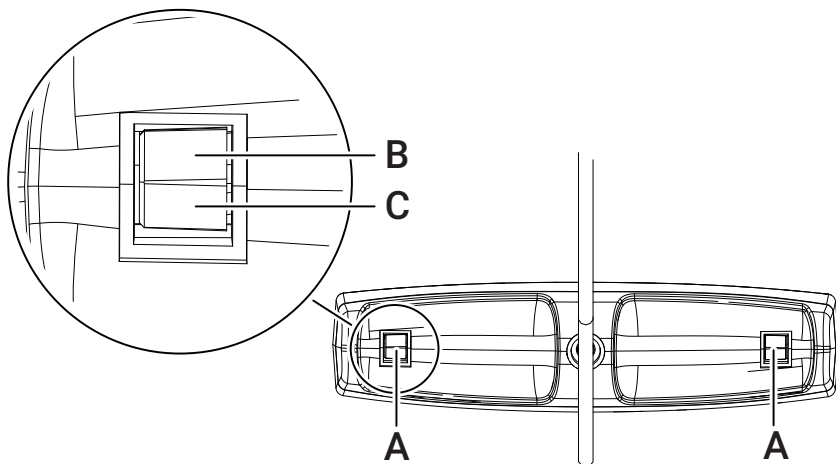

- 2 Use the ¼" wrench/socket to loosen the 2 slotted hex bolts (**D**), and slide the pull cable (**E**) to the desired length.
- 3 The washer (**G**) should be positioned between the clamp (**F**) and the pull handle base.

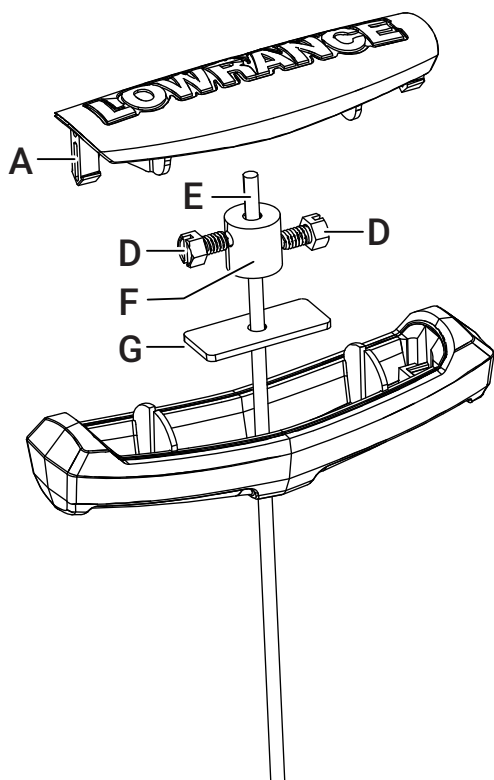

- 4 Apply thread locker to the 2 slotted hex bolts (**D**) if needed. Tighten the slotted hex bolts and cut the pull cable (**E**) approximately 5 mm (1/5") above the clamp (**F**).
- 5 Re-install the handle top cover by pushing it down onto the handle.

## OPERATION

---

This section describes how to operate the trolling motor using the foot pedal.

It is also possible to control the trolling motor from a compatible multi-function display unit (MFD). Refer to the documentation supplied with your MFD for more information.

### Power the trolling motor ON or OFF

Press the power key (A) to power the trolling motor ON or OFF.

The voltage level of the electrical system is indicated when the trolling motor is powered ON.

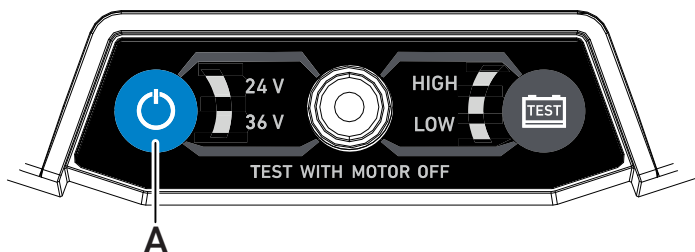

### Check the battery capacity

→ **Note:** The battery capacity should only be checked when the trolling motor is not running.

Press the test key (A) to activate the indicator LEDs.

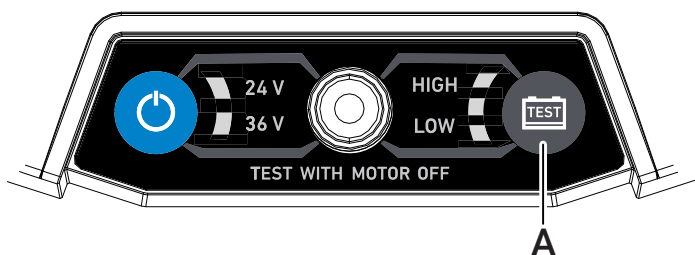

## Steer with the foot pedal

The direction indicator (A) shows the direction in which the lower unit (B) is pointing. Turn to starboard (right) by pushing the toe end (C) of the foot pedal down. Turn to port (left) by pushing the heel end (D) of the foot pedal down.

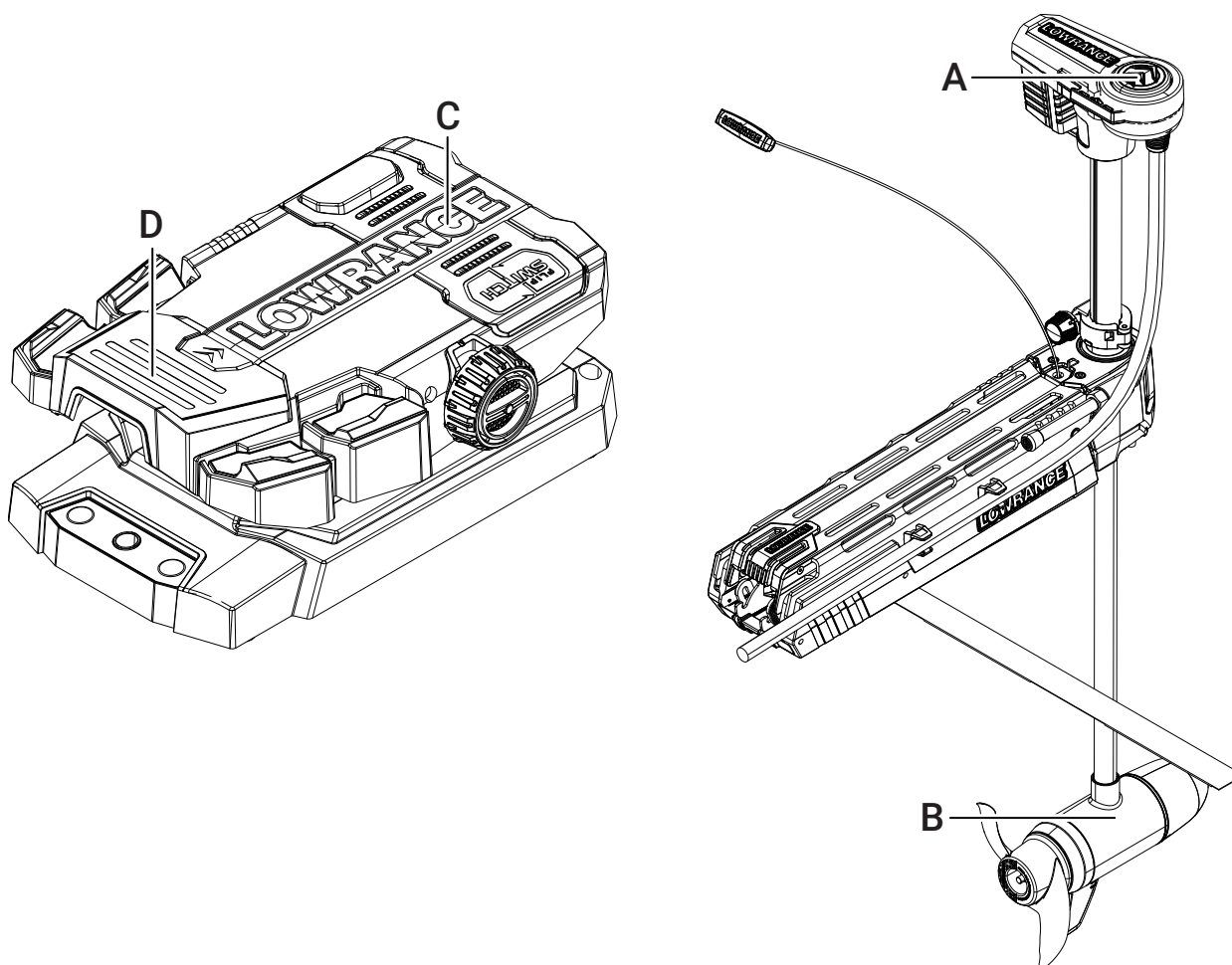

## Activate the propeller

The propeller will run as long as the momentary switch (A) is pressed, provided the speed adjustment knob is not in the OFF position. The propeller will stop when the momentary switch is released.

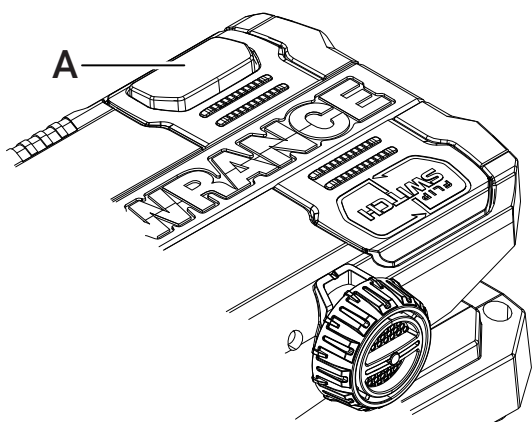

It is also possible to run the trolling motor in Propeller constant ON mode (see **Propeller constant ON mode** on page 18).

→ **Note:** Propeller will not run if the trolling motor is in the stowed position.

## Adjust the speed

Rotate the speed adjustment knob (A) to increase or decrease the propeller speed.

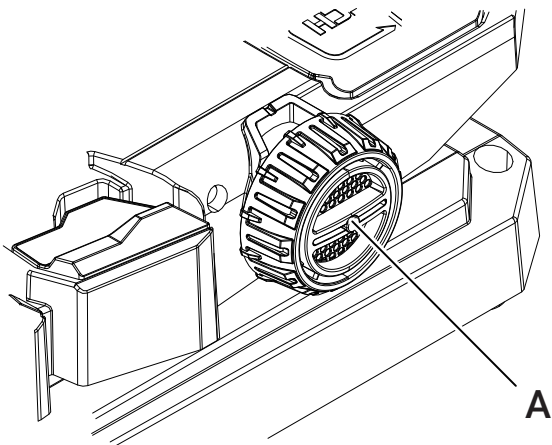

## Select a mode or action

The trolling motor is in manual mode by default, with direction controlled by the foot pedal.

Use a compatible multi-function display (MFD) to access modes and actions. Refer to the documentation for your MFD for more information.

→ **Note:** Visit [www.lowrance.com](http://www.lowrance.com) to ensure your MFD is compatible and its software is up to date. The trolling motor and MFD must be connected to the same NMEA 2000® network.

### Foot pedal keys

You can select modes or actions using the keys on the foot pedal, if the keys have been configured.

→ **Note:** You need a compatible multi-function display unit (MFD) to configure the foot pedal keys. Refer to the documentation for your MFD for instructions.

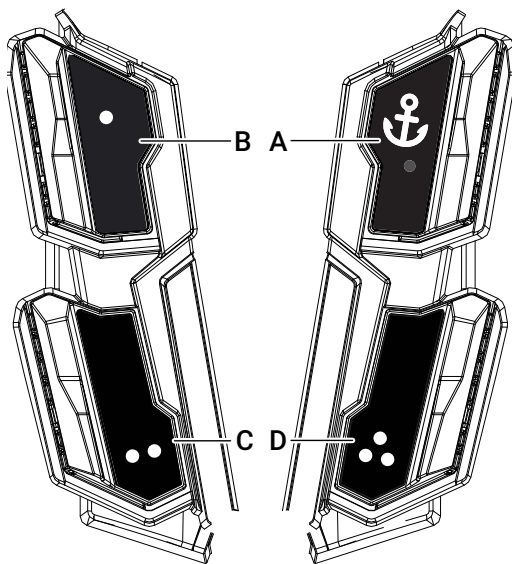

- A Anchor key
- B Configurable key 1. Default function: none.
- C Configurable key 2. Default function: none.
- D Configurable key 3. Default function: none.

## Modes and actions

Some modes of operation for the trolling motor are described below. Refer to the documentation for your display unit for more information about modes and actions.

→ **Note:** The direction indicator is illuminated when in Course lock, Heading lock, or Propeller constant ON mode. In Anchor mode, the direction indicator is illuminated when the propeller is active.

### Anchor mode

Anchor mode maintains the vessel at the current position.

→ **Note:** When in Anchor mode, the vessel heading will be affected by wind and/or current.

### Deactivate anchor mode

Press the Anchor key (A), or the momentary switch, to deactivate Anchor mode.

### Course lock and Heading lock

Course lock mode is an autopilot function that automatically steers the vessel along a straight-line course, compensating for drift caused by current and/or wind. When activated, the trolling motor will draw an invisible track (A) based on the direction of the lower unit.

In Course lock mode, wind and/or current may cause the vessel to follow the course at a crab angle.

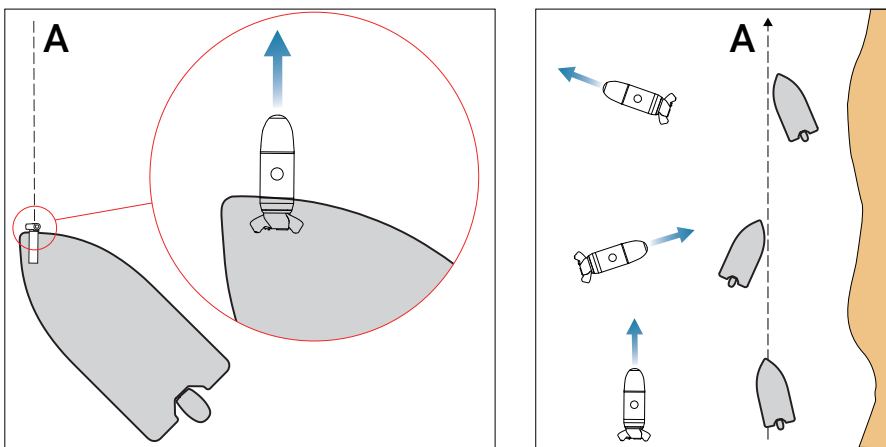

Heading lock mode is an autopilot function that automatically maintains the heading of the vessel, based on the direction of the lower unit.

→ **Note:** In Heading lock mode, the trolling motor does not compensate for drift caused by current and/or wind (C).

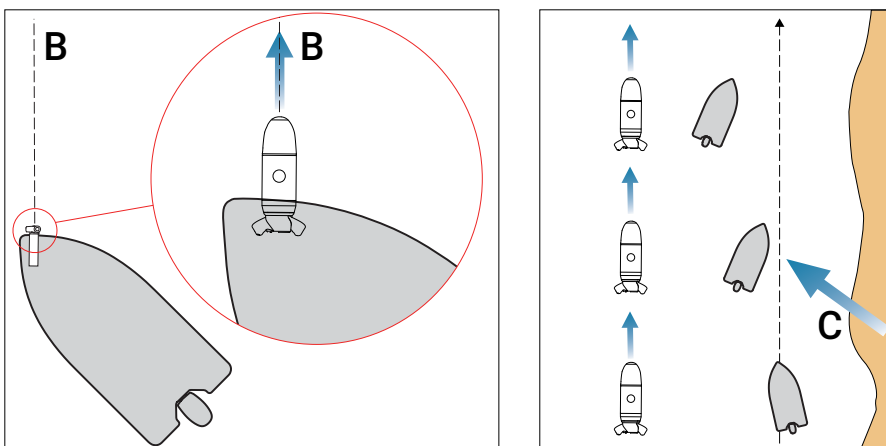

### Adjust speed

Change speed by turning the speed adjustment knob on the side of the foot pedal.

→ **Note:** When the mode is activated, the motor will automatically run to the speed level indicated on the speed adjustment knob.

## **Adjust Course or Heading**

When you are in Course lock or Heading lock mode, press and hold the momentary switch, then use the foot pedal to adjust the course or heading. Release the momentary switch to engage the new position and proceed with the mode.

## **Deactivate Course lock or Heading lock mode**

To deactivate Course lock mode, press the Course lock key once, or move the foot pedal without engaging the momentary switch.

To deactivate Heading lock mode, press the Heading lock key once, or move the foot pedal without engaging the momentary switch.

## **Propeller constant ON mode**

Engages the propeller to spin continuously.

## **Adjust speed**

Change speed by turning the speed adjustment knob on the side of the foot pedal.

→ **Note:** *When the mode is activated, the motor will automatically run to the speed level indicated on the speed adjustment knob.*

## **Deactivate constant ON mode**

Press the Propeller constant ON key, or the momentary switch, to deactivate Propeller constant ON.

# SERVICE AND MAINTENANCE

For service contact information, spare parts and accessories refer to [www.lowrance.com](http://www.lowrance.com).

## General maintenance

**⚠ WARNING:** Neglecting to inspect, maintain, or repair your trolling motor can result in product damage or serious injury. Do not perform maintenance or service on your trolling motor if you are not familiar with the correct procedures.

### Before each use

- Visually inspect the stow/deploy cable and handle for damage or wear. Repair or replace as necessary.
- Check the trolling motor for tightness on the deck mount.
- Visually inspect for loose or corroded electrical wiring/components.
- Inspect the stow strap assembly for damage, fraying or excessive wear.
- Remove any debris interfering with stow strap operation.
- Inspect the trolling motor stabilizer bar height. With the trolling motor in the stowed position, lift the motor slightly off the deck and ensure that the gap between the deck and the rubber foot on the stabilizer bar is less than ½" (13 mm). Ensure the stabilizer jam nut is tight.

### After each use

- Ensure the 6 mm screws securing the motor to the mount are torqued to specification.
- Clean your propeller and inspect it for nicks or abrasions. Remove nicks and abrasions with fine sandpaper or a file.
- Remove the propeller. Remove any fishing line or debris that may be wedged between the propeller and lower unit. Re-install the propeller and propeller nut. Make sure the nut is securely tightened.
- Check the battery leads for cuts or abrasions and repair or replace if necessary.
- Disconnect power when the motor is being stored, transported, or not in use for extended periods of time.
- Recharge your batteries as soon as possible. The ideal state for a battery is fully charged.
- Rinse the trolling motor with fresh clean water after use in a brackish environment.

## Maintenance schedule

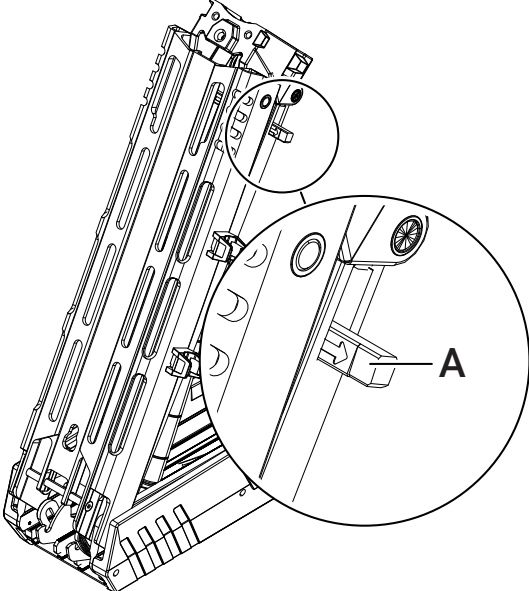
Item	Occurrence	Description
Batteries	Weekly	Check terminals for any corrosion or dirt. Clean if necessary.
<b>Mount</b>		
Front latch block	Yearly	Grease the contact surface (A) of the front latch block with calcium sulfonate marine grease. 
Braided stainless steel pull cable and handle	Before each use	Visually inspect. Replace if damaged.

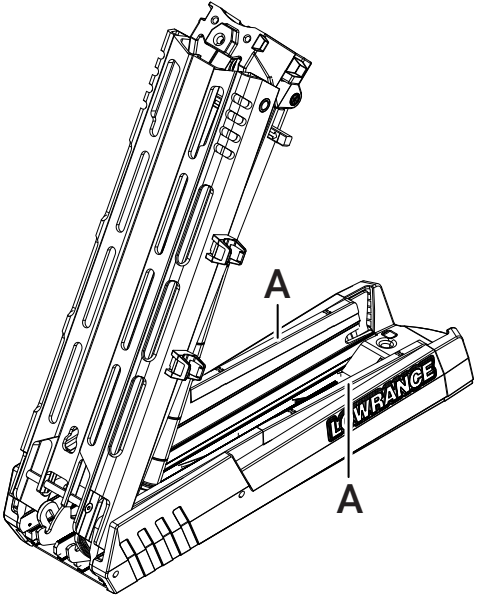
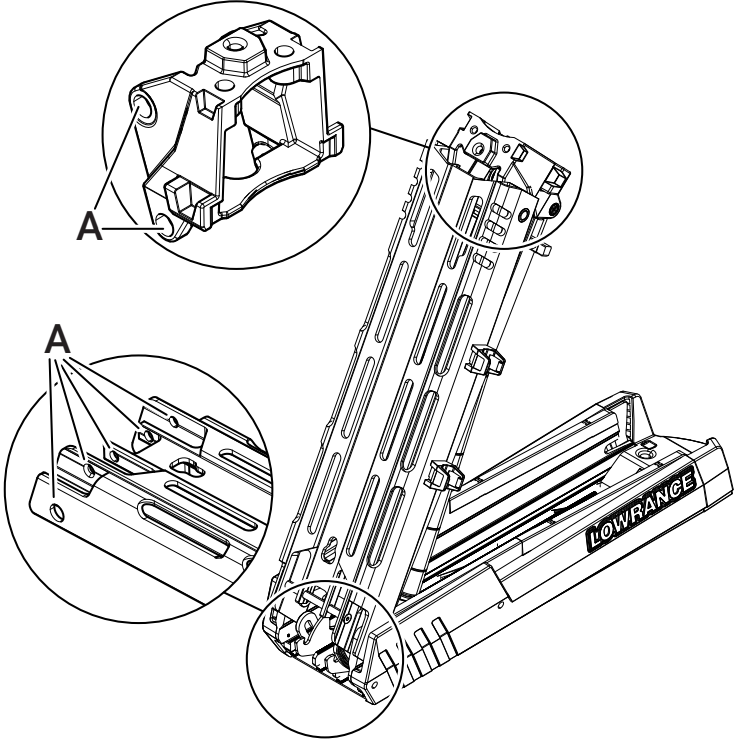
Item	Occurrence	Description
Wear bearing	Yearly	<p>Visually inspect. Replace the wear bearings (A) if necessary.</p>  <p>The wear bearings can be pried off using a wide blade flat screwdriver.</p>
Stow strap	After each use	Replace if damaged.
Stow bow arm/ mount stabilizer	Before each use	Visually inspect. Replace if damaged. Verify the stabilizer properly supports the motor during transportation. Adjust and tighten lock nut as necessary.
Bushings	As necessary	<p>Lubricate brass bushing points (A) with a multi-purpose lubricant.</p>  <p>Remove excess quickly to avoid discoloration or collection of dirt.</p>
<b>Foot pedal</b>		
Electrical terminals	Yearly	Check that terminal screws are not loose. If needed, reapply Tef-Gel® to the terminals.
Trolling motor		
Direction indicator	As necessary	Clean the indicator. Remove the indicator by prying it off with a flat head screwdriver. Blow/clean with rubbing alcohol.

# Propeller replacement

## Tools required

- 17 mm deep socket

**⚠ WARNING:** Do not use power tools to remove or install the propeller nut. Only hand tools should be used for removal and installation of the nut.

## Procedure

Remove the propeller. Inspect the drive pin (A) and propeller shaft (B) for damage. If these parts are damaged, contact a service center.

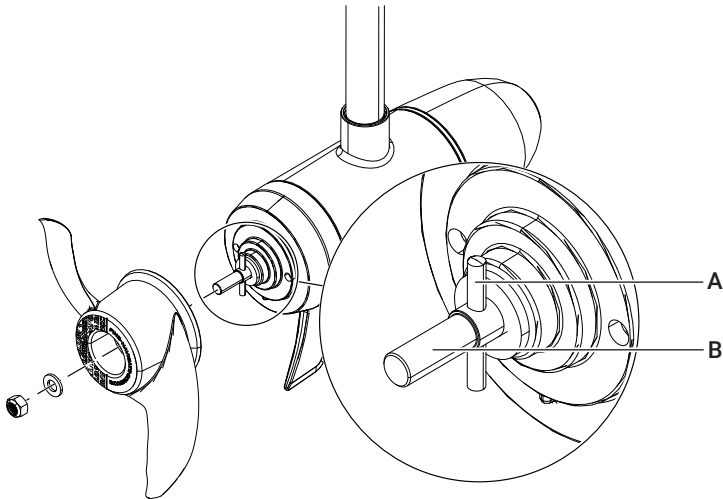

- 1 Clean the threads of the propeller shaft of any pre-existing grease and debris.
- 2 Install the new propeller. Make sure that the drive pin (A) aligns with the slot in the propeller (C). Torque the propeller nut (D) to 13 Nm (10 lbft).

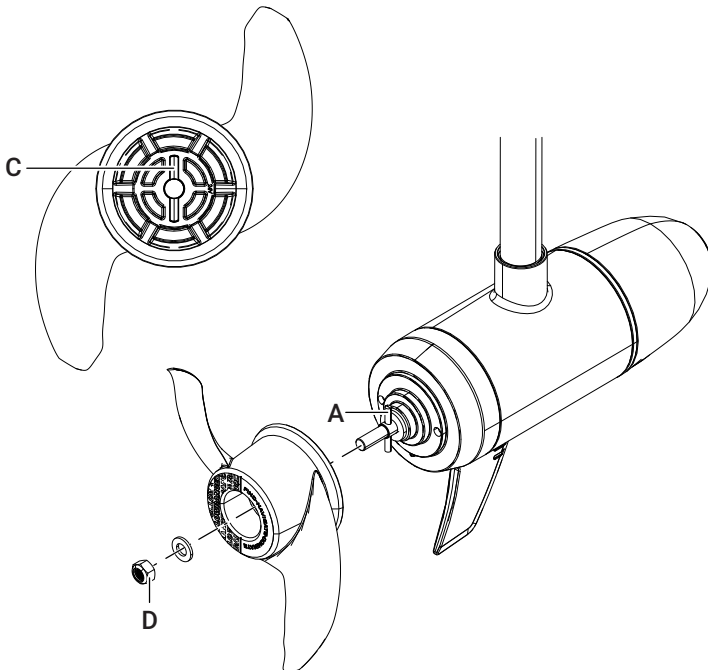

## Configuration mode

All setup is done in configuration mode.

### Enter or exit configuration mode

→ **Note:** Configuration mode is currently accessed using the foot pedal. In future releases, it will also be possible to enter configuration mode using an accessory remote control.

To enter configuration mode, press and hold both Configurable keys 2 and 3 (**C** and **D**) until the Power LEDs (**E**) start blinking. The direction indicator on the upper unit flashes two times and two long beeps sound.

You need to exit configuration mode once you have completed the procedures. To exit configuration mode, press and hold both Configurable keys 2 and 3 (**C** and **D**) until the Power LEDs (**E**) stop blinking. The direction indicator on the upper unit flashes three times and three long beeps sound.

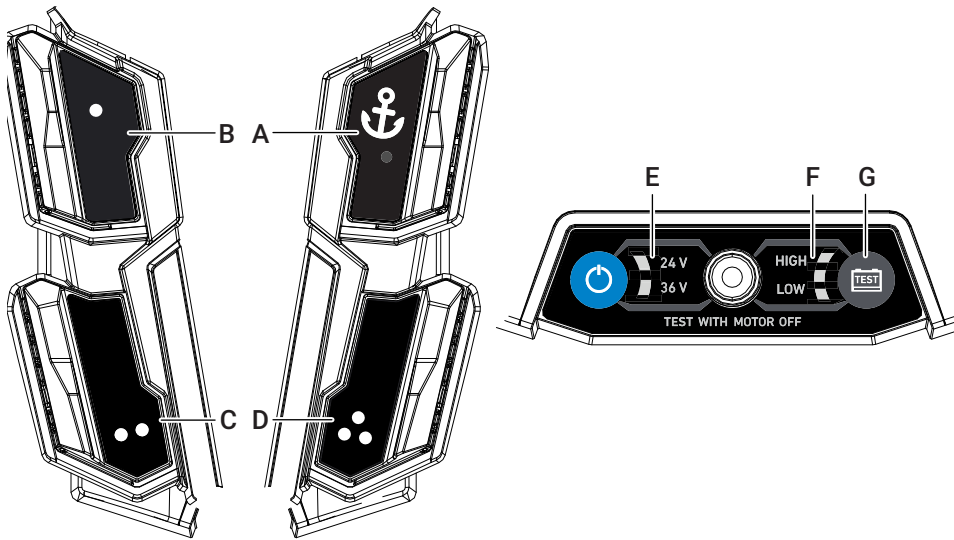

- A Anchor key
- B Configurable key 1. Default function: none.
- C Configurable key 2. Default function: none.
- D Configurable key 3. Default function: none.
- E Power LEDs
- F Battery status LEDs
- G Battery test key

### Select voltage input level

- 1 Enter configuration mode by pressing and holding Configurable key 2 and Configurable key 3 (**C** and **D**) until the Power LEDs (**E**) start blinking.
  - 2 Press the Battery test key (**G**) repeatedly until the Power LED matching your supply (24 V or 36 V) lights.
  - 3 Press and hold the Battery test key (**G**) to save. The direction indicator flashes three times and three long beeps sound.
  - 4 Exit configuration mode by pressing and holding Configurable key 2 and Configurable key 3 (**C** and **D**) until the Power LEDs (**E**) stop blinking, or proceed with other calibrations.
- **Note:** The trolling motor default voltage setting is 24 V. An incorrect voltage setting will not damage the trolling motor.

### Calibration of the bow-mount offset

- **Note:** Before starting the calibration, raise the lower unit as high as is safely possible, to allow you to see the direction of the lower unit.
- 1 Enter configuration mode by pressing and holding Configurable key 2 and Configurable key 3 (**C** and **D**) until the Power LEDs (**E**) start blinking.
  - 2 While watching the lower unit, use the foot pedal to align the lower unit parallel to the centerline of the boat.
  - 3 When the lower unit is parallel to the centerline of the boat, press and release the Anchor key (**A**) to calibrate the bow-mount offset. The direction indicator flashes three times and three long beeps sound.
  - 4 Exit configuration mode by pressing and holding Configurable key 2 and Configurable key 3 (**C** and **D**) until the Power LEDs (**E**) stop blinking, or proceed with other calibrations.
- **Note:** Misalignment between the lower unit and the heading sensor after calibration will cause poor performance in automatic steering modes.

## Calibration of the TMC-1 compass

Calibration compensates for the local magnetic field on board the boat, and adapts the sensors to Earth's magnetic field strength (deviation) for optimal resolution.

→ **Note:** For optimal performance, recalibrate if the boat has traveled far from the location where the TMC-1 was last calibrated. This is because the strength of Earth's magnetic field varies in different locations.

The calibration of the compass should be done in calm conditions, with minimal wind and current, to obtain good results. Ensure that there is enough open water around the vessel to make a full turn. The turn should be carried out using the boat's outboard engine, if one is installed.

- 1 Enter configuration mode by pressing and holding Configurable key 2 and Configurable key 3 (**C** and **D**) until the Power LEDs (**E**) start blinking.
- 2 Press and release Configurable key 3 (**D**). The direction indicator LED starts flashing and two long beeps sound.
- 3 Perform a 390 degree turn (just over one circle) with a steady, stable, low rate of turn (2°–3°/second). This process could take a few minutes. If your rate of turn is too slow or quick, two beeps sound. In this case adjust your rate of turn and perform another 390 degree turn.
- 4 Once calibration is complete, the direction indicator will stop flashing and three long beeps sound.
- 5 Exit configuration mode by pressing and holding Configurable key 2 and Configurable key 3 (**C** and **D**) until the Power LEDs (**E**) stop blinking, or proceed with other calibrations.

## BLUETOOTH® PAIRING

---

- 1 Enter configuration mode by pressing and holding Configurable key 2 and Configurable key 3 (**C** and **D**) until the Power LEDs (**E**) start blinking.
- 2 Press and hold the Battery test key (**G**) until the battery status LEDs (**F**) start blinking. The direction indicator flashes two times and two long beeps sound.
- 3 Pair the trolling motor with your Bluetooth® device.
- 4 When the pairing is completed, the battery status LEDs stop blinking. The direction indicator flashes three times and three long beeps sound. The trolling motor is now paired with your device.
- 5 Exit configuration mode by pressing and holding Configurable key 2 and Configurable key 3 (**C** and **D**) until the Power LEDs (**E**) stop blinking, or proceed with other calibrations.

## FACTORY RESET

---

- 1 Enter configuration mode by pressing and holding Configurable key 2 and Configurable key 3 (**C** and **D**) until the Power LEDs (**E**) start blinking.
  - 2 Press and hold Configurable key 1 and Configurable key 2 (**B** and **C**) until the direction indicator flashes three times and three long beeps sound.
  - 3 All user settings and calibrations are now set to factory defaults.
- **Note:** After completing a factory reset, a bow offset and compass calibration should be performed. All programmable buttons, paired Bluetooth® devices, arrival modes, system voltage, and stow direction will be restored to their default settings.

## LOWRANCE APP

---

Use the Lowrance mobile app to register your Ghost Series trolling motor for support and software updates. Download the app from your favorite application store, or use your phone or tablet to scan the QR code® below.



# SOFTWARE UPDATES

---

## Update from MFD

The trolling motor software can be updated from a microSD® card inserted into a compatible multi-function display unit (MFD). Visit 'Help and support' at [www.lowrance.com](http://www.lowrance.com), and download the latest software to a microSD® card whose capacity is 32 GB or smaller. Refer to the MFD's documentation for details about the update procedure.

## Update from the app

Follow the prompts in the Lowrance mobile app to update the trolling motor software.

A Wi-Fi® or cellphone data connection is required to download the update package to your mobile device. The app connects to the trolling motor via Bluetooth®.

→ **Note:** *Do not disconnect power from the trolling motor while a software update is in progress.*

## Force a software upgrade

In the unlikely event that you receive a software version mismatch error, or if the power LEDs are blinking one at a time (one blink per second), you may need to force a software upgrade.

- 1 Activate configuration mode by pressing and holding Configurable key 2 and Configurable key 3 (**C** and **D**) until the Power LEDs start blinking.
- 2 Press and hold Configurable key 3 and the Anchor key (**D** and **A**).

# TROUBLESHOOTING

Problem	Action
Motor not running	<p>Check battery connections for proper polarity.            Make sure terminals are clean and corrosion free. Use fine sandpaper or emery cloth to clean terminals.            Check the condition of the battery, refer to the battery suppliers recommendations.            Check for proper battery voltage.            Make sure the trolling motor is in the deployed position.</p>
Motor loses power after a short running time	<p>Check battery charge level.            Check power wires and connections, make sure that the correct cable diameter is used.</p>
Direction indicator hangs up or stutters during rotation	<p><b>For Ghost 47", Ghost 52" and Ghost 60":</b>            Clean the indicator.            Remove the indicator by prying it off with a flat head screwdriver. Blow or wash out carefully if necessary.            Verify the white Teflon® sticker is properly placed within the small circle of the gear cover window.            Verify indicator race is free of debris.            Inspect indicator tabs for deformation or flashing. File nicks or imperfections as needed.</p> <p><b>For Ghost X:</b>            Ghost X has a remodelled direction indicator.            To remove the indicator, gently lift evenly around the indicator cap so as not to damage the support material. Blow or wash out carefully if necessary.</p>
Direction indicator does not seem aligned to lower unit direction	<p>Contact a service center.</p>
Propeller vibration during operation	<p>Ensure thrust washer is seated correctly and make sure the propellor nut is tight.            Inspect the propeller and propeller shaft for damage, and file nicks or imperfections as needed.</p>
Anchoring or heading issues	<p>Perform calibration of the compass and/or bow offset. Refer to the installation manual.            Validate TMC-1 compass installation location is sufficient and in a position free of magnetic interference.</p>
Trolling motor does not appear as a device in the display unit	<p>Check the NMEA 2000® wiring.            Make sure that the proper sources have been selected. Refer to the documentation supplied with your display unit for more information.</p>
Cannot get the sonar to work	<p>Check the sonar wiring.            Verify the sonar is properly set up on the compatible multi-function display unit.</p>
Motor is hard to stow	<p>Loosen the mounting bolts 1–2 turns to verify the mount is not unevenly tightened to the mounting surface.            Place your foot on top of the mount and press down before unlatching the mount via the stow cable.            Place shims or included rubber spacers between the boat deck and the bottom of the mount to create a level mounting surface.            Ensure the bolts (6 mm Allen head) connecting the steering system to the mount are tight.            On new installation, cross check steering system was installed with the mount in the deploy position.</p>

Problem	Action
Remote control does not pair to trolling motor	Stop the pairing process and perform a factory reset of the trolling motor. After the factory reset is complete, power on the trolling motor. Start over with remote's pairing sequence. → <b>Note:</b> After performing the trolling motor factory reset, you'll need to re-calibrate the bow offset, and re-configure the foot pedal keys and battery voltage.
Motor is hard to deploy	Check for proper installation and spacing on the stabilizer. Check to ensure the mount is level. Add grease to latches. Inspect wear bearings for damage (see <b>Maintenance schedule</b> on page 19).

## Direction indicator LED and audible feedback

The direction indicator light (A) is the set of three illuminated arrows on the top surface of the upper unit.

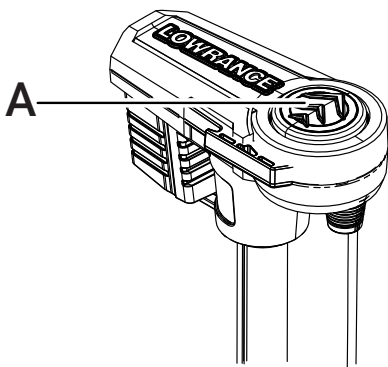

Audible tones	Direction indicator light	Status/description
NA	ON (steady)	Propeller is running.
1 short beep	OFF	Enabling anchor mode.
		Enabling heading lock mode.
		Enabling course lock mode.
		Enabling constant ON mode.
2 short beeps	OFF	Disabling anchor mode.
		Disabling heading lock mode.
		Disabling course lock mode.
		Disabling constant ON mode.
4 short beeps	OFF	Trolling motor startup sequence completed.
2 long beeps	2 long flashes	Calibration initiated.
		Broadcast Bluetooth® pairing.
3 long beeps	3 long flashes	Calibration completed.
		Bluetooth® pairing completed.
		Factory reset completed
4 long beeps	4 long flashes	Battery level below threshold. Unit will shut off.
NA	Blinking at a rate of 1 Hz	During upgrade of motor components.
		During compass calibration

## Error codes and troubleshooting

Audible tones and direction indicator flashes	Error	Troubleshooting	Resolution
<b>3 short beeps</b> 2 short flashes	<b>Missing GPS/invalid heading</b> Missing GPS signal, or invalid heading data.	Check the TMC-1 (compass puck) connection, and recalibrate bow offset (see page <b>22</b> ).	If the issue persists after performing calibration, please contact a service center.
<b>5 long beeps</b> 3 short flashes	<b>Invalid shaft angle</b> No steering or erratic steering; auto-stow/deploy not functioning.	Recalibrate the bow offset (see page <b>22</b> ) then test whether steering and/or stow features are restored.	
<b>5 long beeps</b> 4 short flashes	<b>Invalid pedal angle</b> Pedal PCBA not communicating with main PCBA; broken or unplugged communication wire.	Power cycle: trip the circuit breaker or disconnect the motor from batteries, then reconnect the motor and test for operation.	If the issue persists after performing a power cycle, please contact a service center.
<b>5 long beeps</b> 5 long flashes	<b>High temperature</b>	Stop the trolling motor and disconnect power. Park the boat in a cool spot if possible.	
<b>5 long beeps</b> 10 fast triple flashes	<b>Software version mismatch</b>	Refer to <b>Force a software upgrade</b> on page <b>24</b> .	
<b>5 long beeps</b> 5 short flashes	<b>Propulsion motor error</b>	Inspect the propeller shaft for fishing line, and remove fishing line if applicable. Check all power connections between the trolling motor pedal and the batteries, then perform a load test on batteries.	If the issue persists, please contact a service center.
<b>5 long beeps</b> 6 short flashes	<b>Configuration error</b> Steering motor driver issue; communication issue.	Power cycle: trip the circuit breaker or disconnect the motor from batteries, then reconnect the motor and test for operation.	If the issue persists after performing a power cycle, please contact a service center.
<b>6 long beeps</b> 6 long flashes	<b>Not calibrated</b> Shaft angle and/or pedal angle not calibrated.	Recalibrate the bow offset (see page <b>22</b> ).	If the issue persists after performing calibration, please contact a service center.

## Foot pedal LED indicators

The trolling motor power LEDs (**A,B**) and the battery capacity indicator LEDs (**C,D,E**) are under the heel, at the rear of the foot pedal. The Anchor mode key (**F**) is on the top surface of the foot pedal.

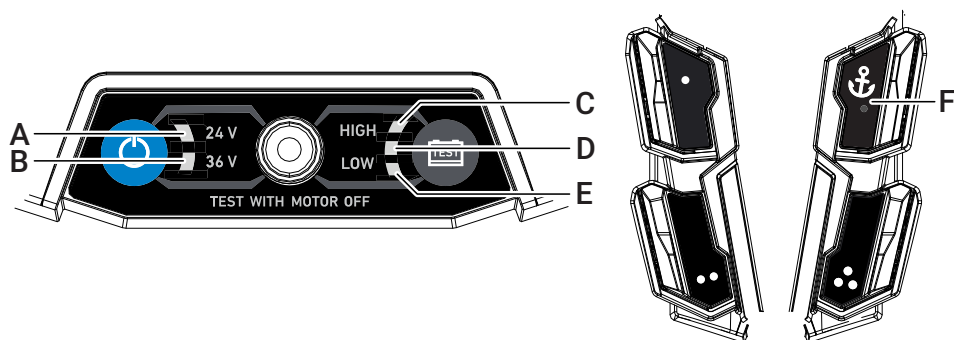

LED	Routine use (24 V system)	Routine use (36 V system)	
<b>A</b>	24 V	ON	OFF
<b>B</b>	36 V	OFF	ON
<b>C</b>	HIGH (battery capacity)	ON if battery > 23.6 V	ON if battery > 35.4 V
<b>D</b>	MID (battery capacity)	ON if battery is 23.0–23.6 V	ON if battery is 34.5–35.4 V
<b>E</b>	LOW (battery capacity)	ON if battery < 23.0 V	ON if battery < 34.5 V
<b>F</b>	Anchor key	ON when Anchor is the current mode	

LED	During startup	During upgrade of motor components	If upgrading of motor components failed	
<b>A</b>	24 V	ON	Blinking fast (10 Hz), one at a time	
<b>B</b>	36 V	ON		
<b>C</b>	HIGH (battery capacity)	ON	OFF	OFF
<b>D</b>	MID (battery capacity)	ON	OFF	ON if Bluetooth® module upgrade failed
<b>E</b>	LOW (battery capacity)	ON	OFF	ON if main controller upgrade failed
<b>F</b>	Anchor key	OFF	OFF	OFF

## Serial number

The serial number of the trolling motor can be found underneath the heel end (**A**) and the toe end (**B**) of the foot pedal.

