

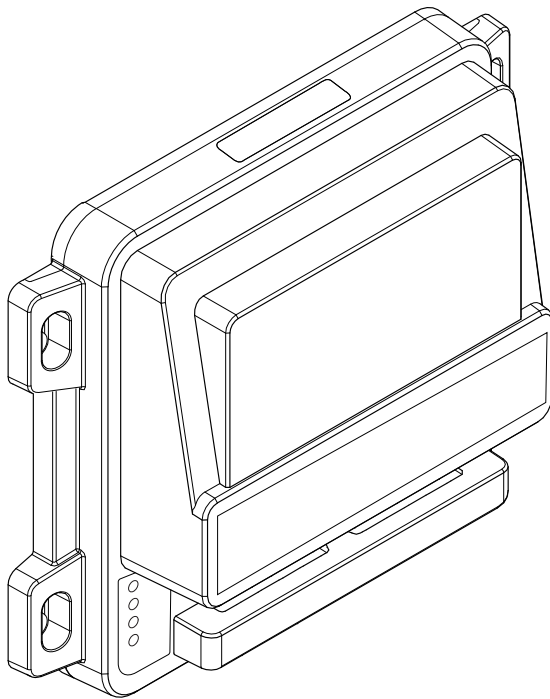

HERCULES® and HERCULES® WTP INSTALLATION GUIDE

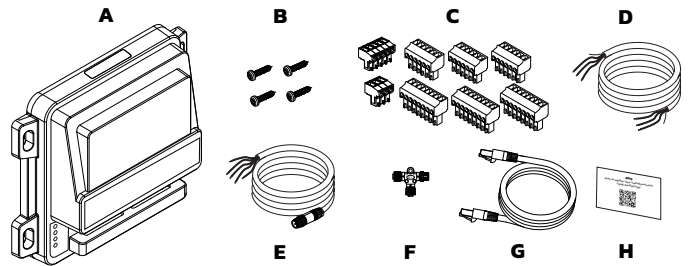

Parts included



- A Hercules® or Hercules® WTP sailing processor
- B Mounting screws (PH2, 19.05 mm / 0.75 in)
- C Connector pack
- D Power cable (3 m / 9.8 ft)
- E NMEA 2000® cable (1.2 m / 4 ft)
- F NMEA 2000® connector
- G Ethernet cable (3 m / 9.8 ft)
- H Registration details card

Mounting

Hercules® and Hercules® WTP sailing processors can be mounted vertically or horizontally.

To prevent interference between the unit and the vessel's compass(es), ensure the unit is at least 50 cm (20 in) away from any compass.

Mark the hole positions and drill pilot holes.

Use a #2 Phillips head screwdriver to secure the sailing processor with the four supplied screws.

CAUTION: Always wear appropriate eyewear, ear protection and dust mask when drilling, cutting, or sanding. Remember to check the reverse side of all surfaces whenever drilling or cutting.

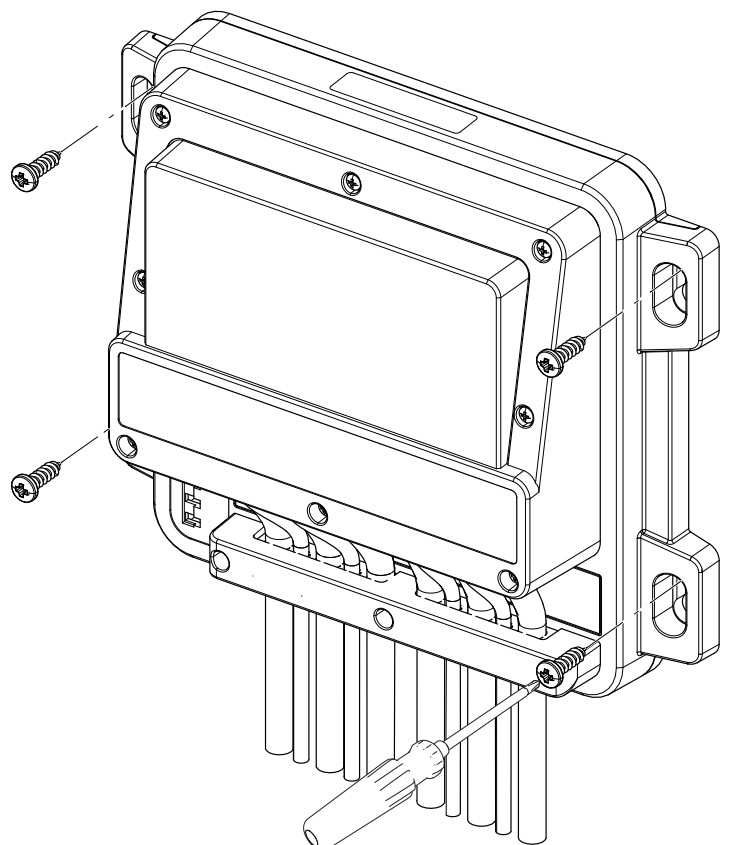

Access the connectors

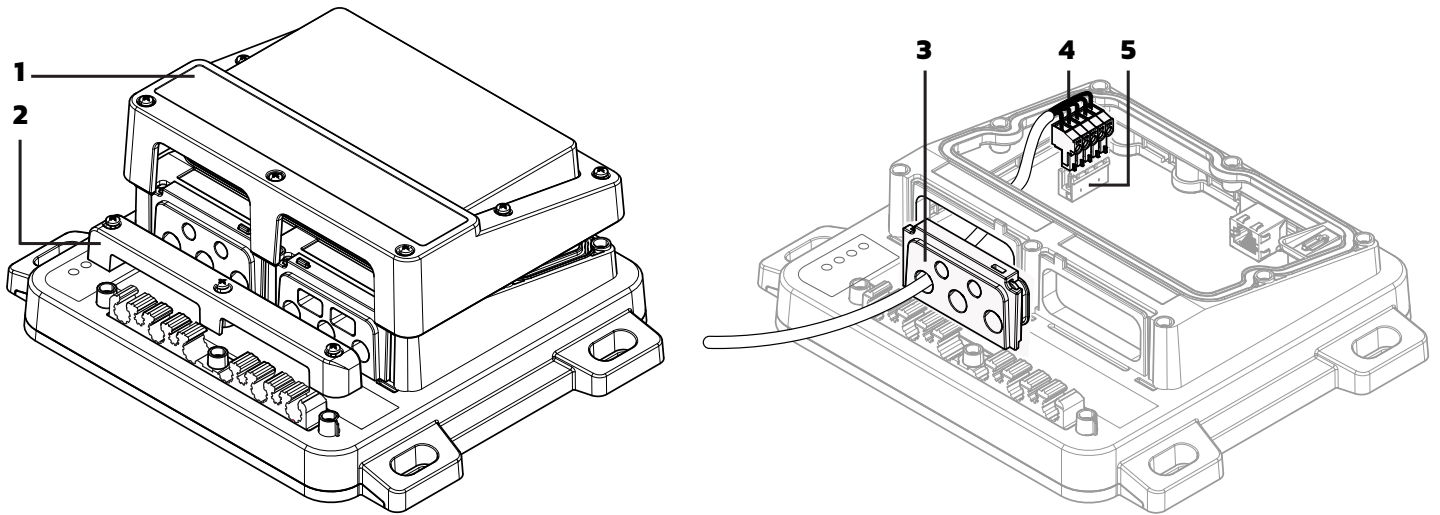

→ **Note:** The sailing processor and your instruments should be powered off while you are connecting wires.

Refer to the connector layout diagram below to identify the functions of the pins and plan the connections on the printed circuit board (PCB).

Use a #1 Phillips head screwdriver to loosen the captive screws on the front of the unit. The screws remain in their recesses.

Lift away the front cover (1) and the cable retainer (2), and ease out one of the flexible cable gland plates (3).

Use the screwdriver to pierce a hole through the gland plate, in a position close to the connector you are wiring.

Feed the cable through the hole and opening in the base of the sailing processor before terminating the wires in the correct connector (4) and plugging the connector into its port (5).

When you've completed installation and testing of the connections, replace the cable gland plates, the cable retainer, and the front cover. Retighten all the screws.

Connector layout

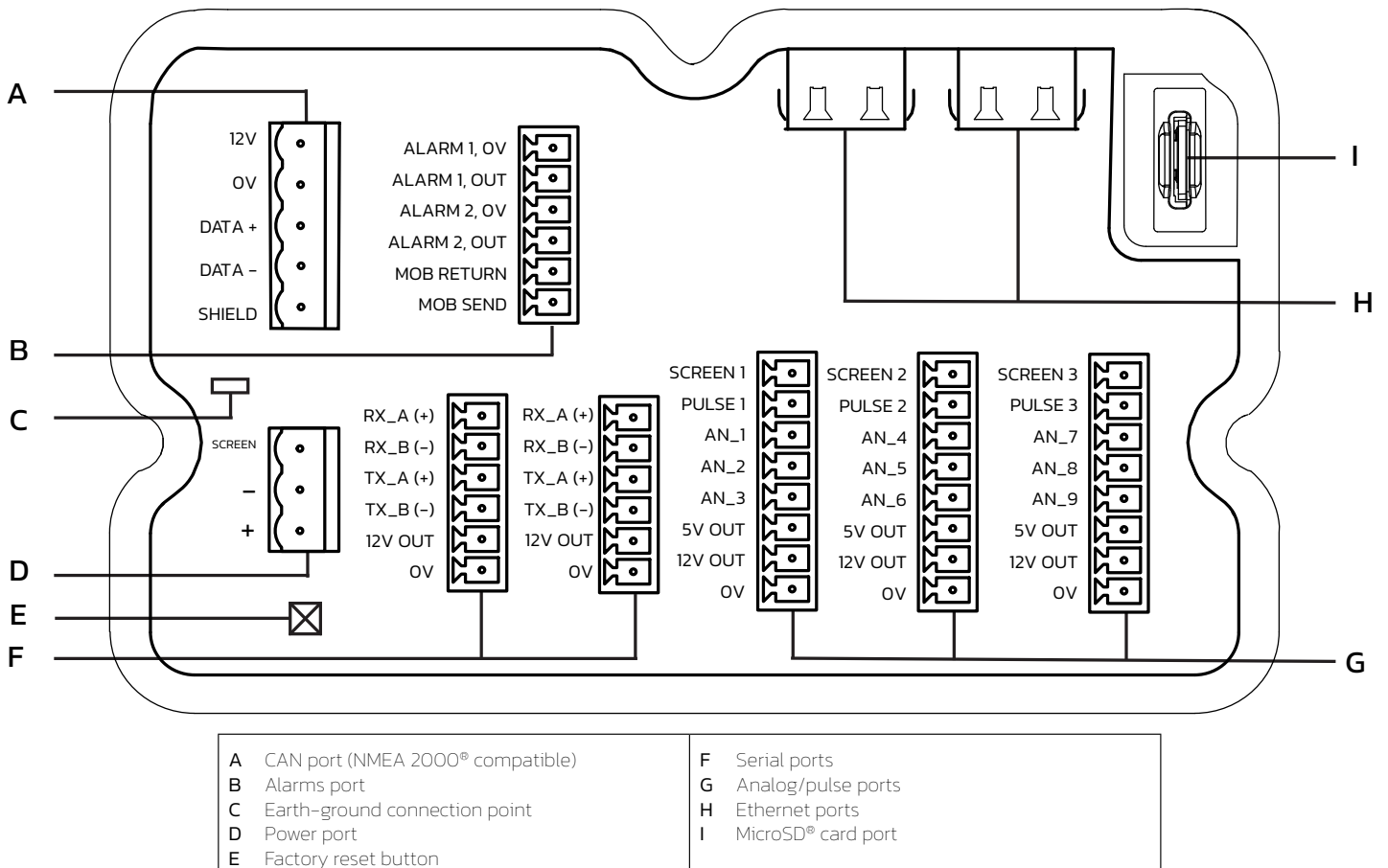

After you've connected any serial, analog, and alarms ports, configure them by navigating to the **Inputs/Outputs** menu on the Hercules® web interface.

→ **Note:** Any of the three analog/pulse connectors can be configured for wind.

Connect the power cable

If required, strip the ends of the supplied power cable to expose three insulated wires, and separate the drain wire from the cable shield at one end.

At the power connector on the PCB, terminate the bare (drain) wire at the screen pin (1). Terminate the black and red wires at the negative and positive pins (2 and 3 respectively).

Connect a 3 A fuse to the positive terminal of a 12 V or 24 V DC power supply.

Connect the red and black wires in the power cable to the positive and negative terminals of the power supply, respectively. The bare (drain) wire is not used at the power supply end of the cable, and should be cut.

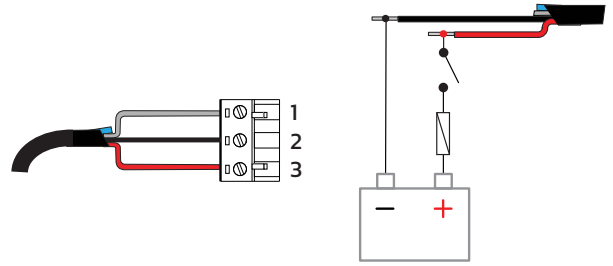

Optional: Earth-ground wire (blue)

The blue wire in the power cable can be used to create a bleed path for excess charge. Connect the blue wire to both the Earth-ground connection point (C) on the PCB, and a point on the hull in electrical contact with the water. If you don't require the blue wire, cut back both its ends.

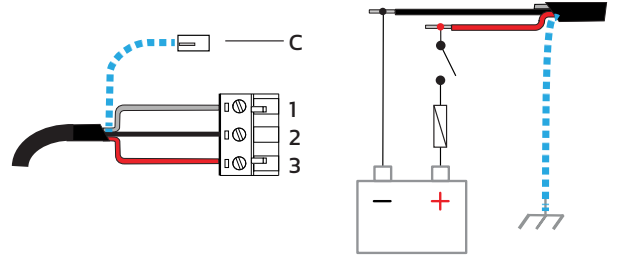

Connect the CAN (NMEA 2000®) cable

A NMEA 2000® network requires its own power supply protected by a 3 A fuse.

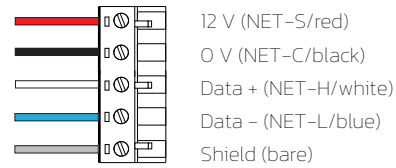

Wiring examples

Refer to the Quick Start Guide for more wiring examples.

- 1 Analog/pulse terminal 1 example: wiring for a 213 mast head unit
- 2 Analog/pulse terminal 2 example: wiring for a speed (paddlewheel) sensor, and three configurable analog sensors
- 3 Alarms terminal example: wiring for an overboard button input with audible alarm

→ **Note:** Wire colors depend on your sensor. Refer to the documentation for your sensors.

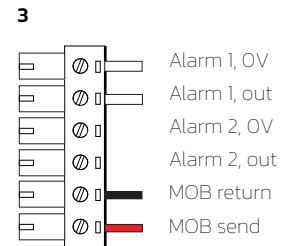
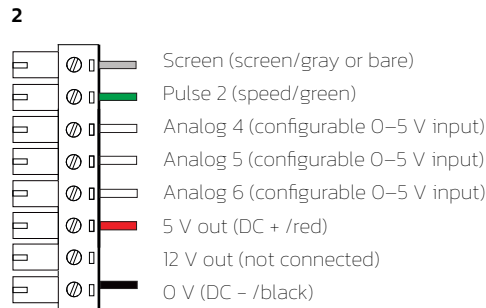
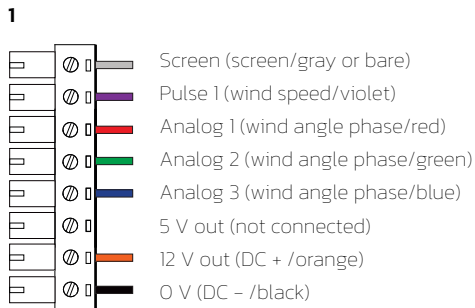

System examples

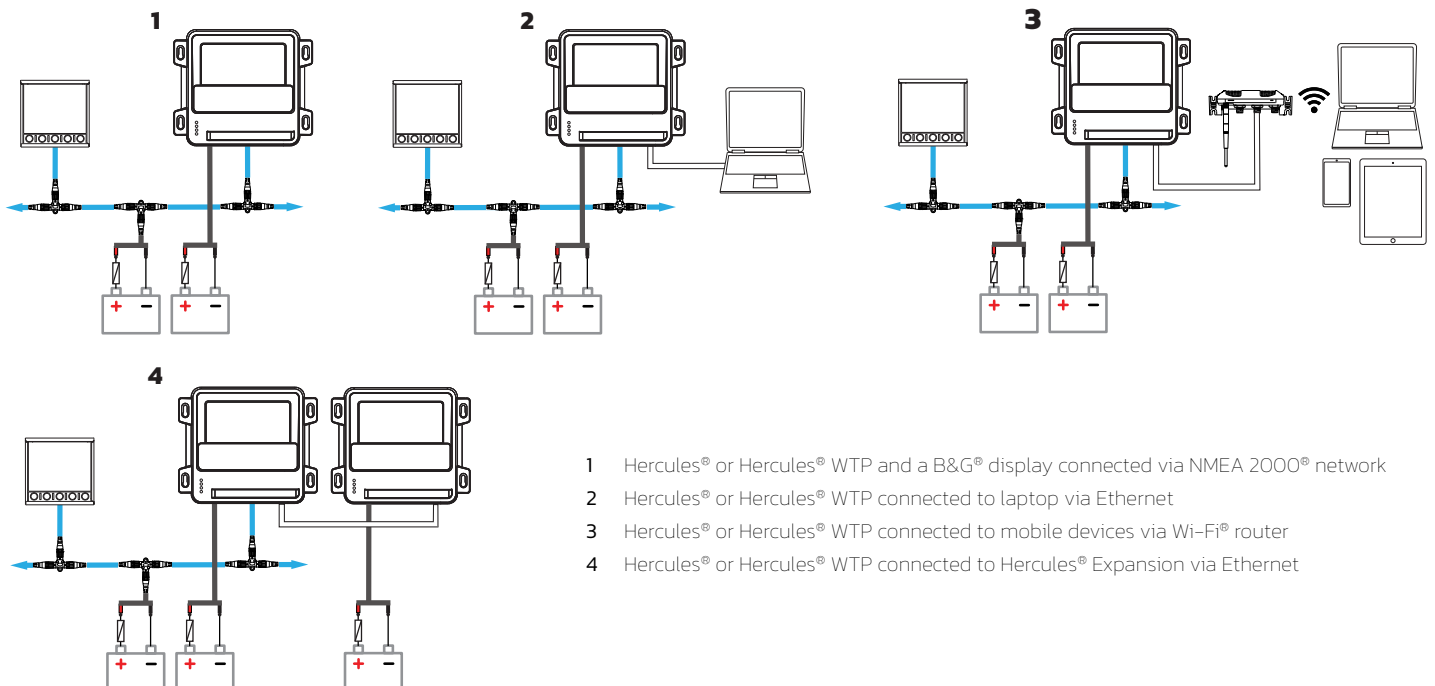

Technical specifications

Environmental	
Operating temperature range	-15°C to 55°C (5°F to 131°F)
Storage temperature	-40°C to 85°C (-40°F to 185°F)
Waterproof rating	IPX6
Electrical	
Supply voltage	12/24 V DC (9.0–31.2 V DC)
Recommended fuse rating	3 A
Maximum power consumption	19 W max at 13.8 V
CAN bus power consumption	< 0.24 W at 12 V 1 LEN (NMEA 2000®)
Physical	
Weight	0.70 kg (1.55 lb)
Interface/Connectivity	
CAN	1 port (5-pin terminal connector) NMEA 2000® compatible
Serial	2 ports NMEA 0183® compatible
Analog	9 channels
Pulse	3 channels
Data card reader	1 port (microSD™)
Ethernet	2 ports (RJ45 connectors, 100BASE-T)

Warranty

This product's warranty is supplied as a separate document.

Safety, disclaimer, and compliance

This product's safety, disclaimer and compliance statements are supplied as a separate document.

Trademarks

®Reg. U.S. Pat. & Tm. Off. and ™ common law marks. Visit www.navico.com/intellectual-property to review the global trademark rights and accreditations for Navico Group and other entities.

© 2023 Navico Group. All Rights Reserved. Navico Group is a division of Brunswick Corporation.

More information

Document version 001.

For the latest version of this document in supported languages, and other related documentation, visit www.bandg.com/downloads/hercules



Dimensions

