

Double Pole On/Off EZ-Mount Battery Switch

770-DP-EZ (Retail Packed)
770-DP-EZ-B (Bulk Packed)

Specifications:

- Continuous rating: 400A
- Intermittent rating: 600A (5min)
- Cranking rating: 1500A (10sec)
- 12-48V DC
- Connection stud size: M10 (3/8")
- IP66 – protection from powerful water jets
- CE marked
- Ignition Protected
- Stud nuts - 13.5nm (10lbf)

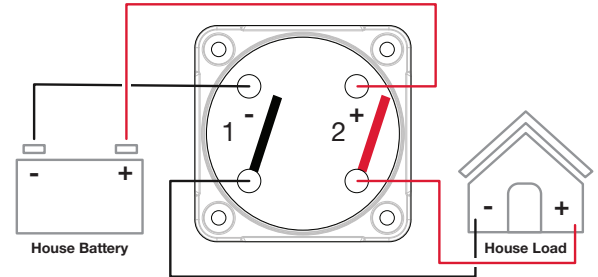

Note: This diagram is a guide only. It is not intended as a full electrical systems wiring diagram.

Dimensions:

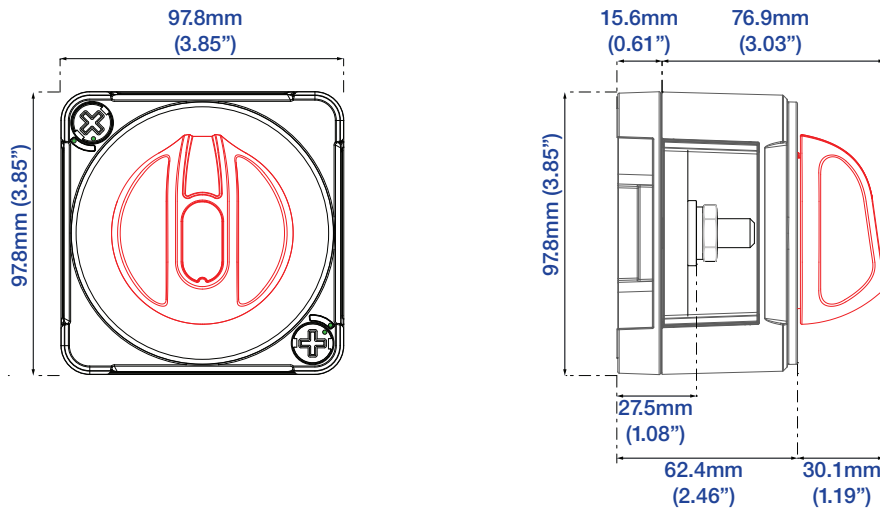

Surface EZ-Mount Instructions:

1. Disconnect battery positive leads at the batteries for safety while installing switch
2. Choose mounting location on a flat surface close to the batteries
3. Drill holes and screw switch base into position
4. Support cables so unnecessary strain is not placed on the battery switch
5. Tighten stud nuts to 13.5 Nm (10 lbf) ensuring spring washers are beneath nuts
6. Install actuator with both switch base and Actuator in "OFF" positions
7. Lock the Actuator fastening screws

Replacement of Actuator:

Always remove, and replace the Actuator with knob in the "OFF" position.

1. Check that contact base hasn't been rotated, the center arrow should point towards "OFF"
2. Ensure that the light grey fastening screws are in the "unlocked" position
3. Ensure that Actuator knob is rotated to the "OFF" position
4. Replace Actuator

Important Installation Instructions:

- It is recommended that electrical terminations and connections are carried out by a marine electrical technician
- Disconnect battery positive leads at the batteries for safety while installing switch
- These battery switches are for isolation purposes and are not designed for switching under load
- Ensure there are no circuits with high inductive loads directly connected to the switch in order to prevent any sudden in-rush of current which may cause damage to the switch
- Although specially selected chemical resistant materials have been used, we recommend that for maximum product life only plastic safe corrosion inhibiting sprays are used
- Ensure all cables are sized correctly for the loads they carry
- Ensure all electrical connections are correctly tightened to prevent any damage to the battery switch
- Turn all appliances off before turning the battery switch to OFF
- Do not switch to OFF while engine is running

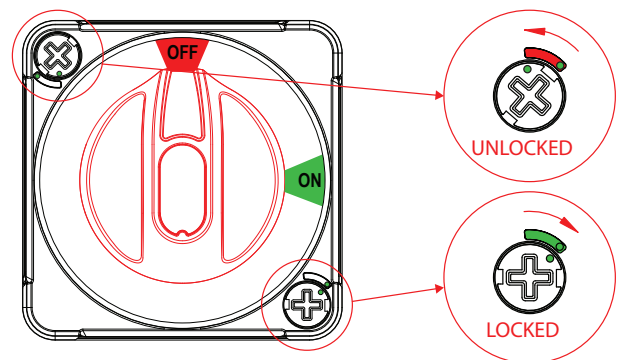

Standard Mount

770
 770-DP
 771-S
 771-SFD
 772-DBC

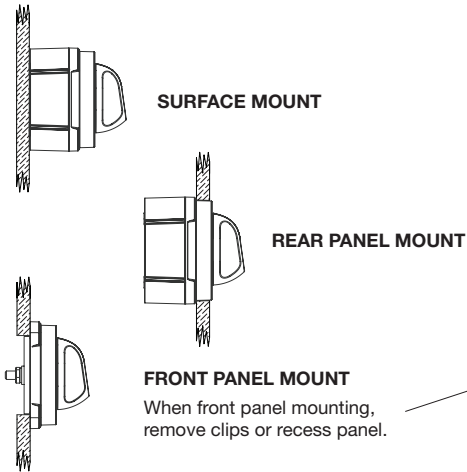



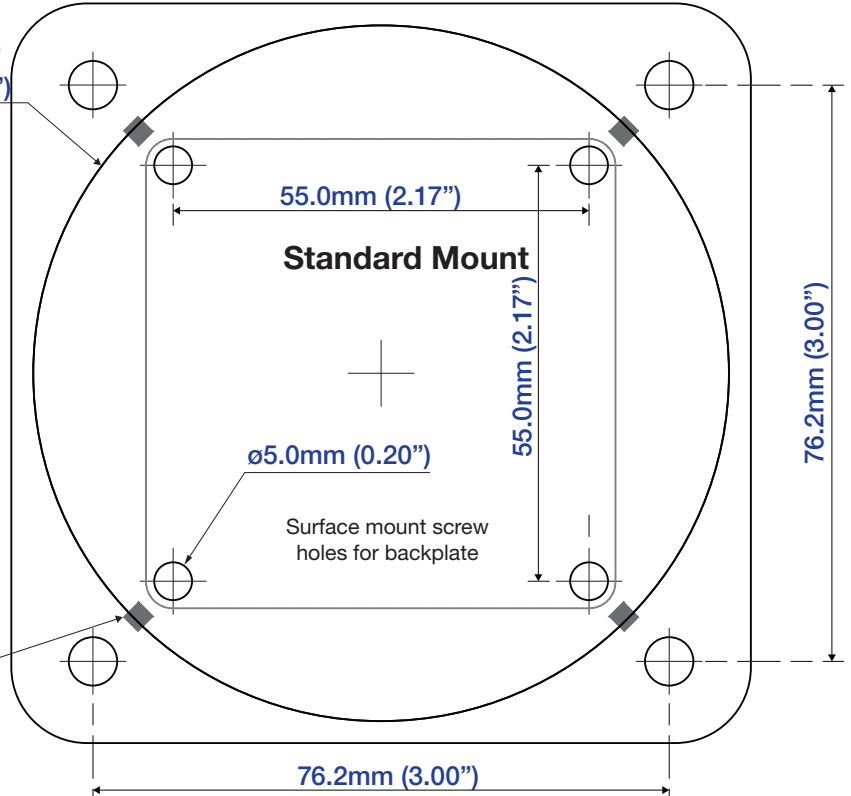

(3 5/8" holesaw)
 \varnothing 92.0mm (3.62")

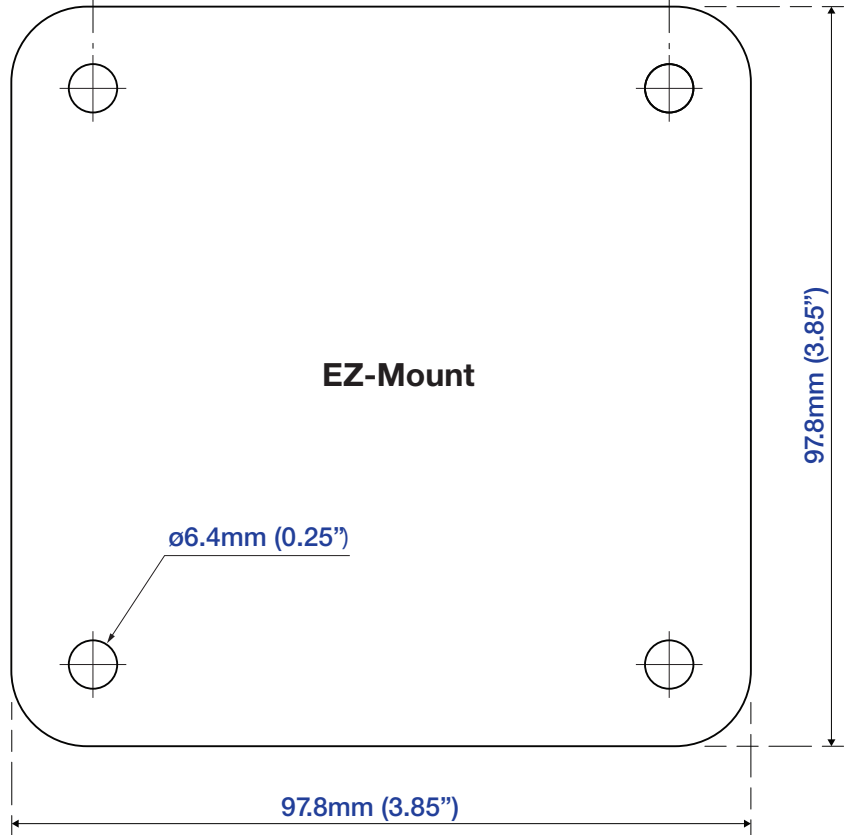

EZ-Mount

770-EZ
 770-DP-EZ
 771-S-EZ
 772-DBC-EZ



- ✓  Socket/Cheesehead
- ✓  Panhead
- ✗  Counter Sunk

Please check scale before using

